



RIGA TECHNICAL
UNIVERSITY

Viesturs Zimackis

METHODOLOGY FOR LIGHTNING PROTECTION DEVICE PLACEMENT IN MEDIUM VOLTAGE OVERHEAD LINES WITH COVERED CONDUCTORS

Summary of the Doctoral Thesis



RTU Press
Riga 2018

RIGA TECHNICAL UNIVERSITY

Faculty of Power and Electrical Engineering

Institute of Power Engineering

Viesturs Zimackis

Doctoral Student of the Study Programme “Power and Electrical Engineering”

**METHODOLOGY FOR LIGHTNING
PROTECTION DEVICE PLACEMENT IN
MEDIUM VOLTAGE OVERHEAD LINES WITH
COVERED CONDUCTORS**

Summary of the Doctoral Thesis

Scientific supervisor:

Professor Dr. sc. ing.

Sandra VITOLINA

RTU Press

Riga 2018

Zimackis V. Methodology for Lightning Protection Device Placement in Medium Voltage Overhead Lines with Covered Conductors. Summary of the Doctoral Thesis. Riga: RTU Press, 2018. 36 p.

Published in accordance with the decision of the Promotion Council "P-14" of October 8 2018, Minutes No. 2018 5(67).

DOCTORAL THESIS PROPOSED TO RIGA TECHNICAL UNIVERSITY FOR THE PROMOTION TO THE SCIENTIFIC DEGREE OF DOCTOR OF ENGINEERING SCIENCES

To be granted the scientific degree of Doctor of Engineering Sciences, the present Doctoral Thesis has been submitted for the defence at the open meeting of RTU Promotion Council on December 18, 2018, at 10:00 am at the Faculty of Power and Electrical Engineering of Riga Technical University, 12/1 Azenes Street, Room 212.

OFFICIAL REVIEWERS

Dr. habil. sc. ing. Imants Matiss
Latvian Academy of Sciences

Dr. sc. ing. Vilnis Kreslins
Latvian Association of Power Engineers and Energy Constructors

Dr. sc. ing. Saulius Gudzius
Kaunas University of Technology, Lithuania

DECLARATION OF ACADEMIC INTEGRITY

I hereby declare that the Doctoral Thesis submitted for the review to Riga Technical University for the promotion to the scientific degree of Doctor of Engineering Sciences is my own. I confirm that this Doctoral Thesis had not been submitted to any other university for the promotion to a scientific degree.

Viesturs Zimackis (signature)

Date:

The Doctoral Thesis has been written in Latvian. It consists of Introduction; 6 Chapters; Conclusion; 64 figures; 32 tables; 22 appendices; the total number of pages is 135. The Bibliography contains 130 titles.

TABLE OF CONTENTS

INTRODUCTION.....	5
1. PLACEMENT OF PROTECTION DEVICES IN COVERED CONDUCTOR OVERHEAD LINES.....	8
2. LIGHTNING CURRENT AND ITS MATHEMATICAL MODELS.....	11
3. DETERMINATION OF THE POINT OF STRIKE.....	14
3.1. Lightning incidence.....	14
3.2. Lightning discharge statistics in Latvia.....	15
3.3. Impact of nearby objects on the number of direct lightning strikes.....	16
4. OVERVOLTAGES IN MEDIUM VOLTAGE NETWORK.....	18
4.1. Direct and indirect lightning strike caused overvoltages.....	18
4.2. Critical flashover voltage of medium voltage overhead lines with covered conductors.....	20
4.2. The influence of the covered conductor depreciation on the CFO.....	22
5. PROPOSED ALGORITHM FOR EVALUATION OF LIGHTNING PROTECTION DEVICES PLACEMENT FREQUENCY.....	24
5.1. Suggested criteria for placement of covered conductor lightning protection devices.....	24
5.2. Structure of algorithm.....	25
5.3. Extended explanation of the methodology and application example.....	26
6. VERIFICATION OF PROPOSED METHODOLOGY.....	31
MAIN RESULTS AND CONCLUSIONS.....	34
BIBLIOGRAPHY USED IN SUMMARY.....	35

INTRODUCTION

The topicality of the work

Covered conductor overhead lines are the most cost-effective solution by rebuilding the 20 kV distribution network in forest areas, because the reduced dimensions of line and fallen trees do not cause significant damage to the line. For this reason, in Latvia, about half of the 20 kV lines are being reconstructed into covered conductor lines [5]. For the last 40 years, the number of covered conductor lines has grown rapidly, for example, in Finland and Sweden the share of covered conductor lines is around 80 % [1] of newly constructed medium voltage lines. By rebuilding bare conductor overhead lines into covered conductor lines, the number of damages caused by natural phenomena decreases more than 10 times [27], which reduces the system average interruption duration index (SAIDI), system average interruption frequency index (SAIFI) and momentary average interruption frequency index (MAIFI) [7]. The number of permanent faults of covered conductor lines per 100 km is almost 3 times smaller than of underground cable lines [27], which makes them an effective, economical and environmentally friendly way to reduce faults in distribution network.

With covered conductor lines, special attention should be paid to overvoltage protection, since the electric arc generated by direct or indirect lightning strike cannot move along the line due to insulation, as in the case of bare conductor overhead lines. Operation time of the line protection device is sufficiently long to cause damage to insulation of covered conductor, which can cause further damage to the conductor itself and increase the number of faults and power interruptions. An effective way to deal with damage caused by lightning induced electric arc is to install arc protection devices on covered conductors.

According to Standard EN 50397-3 [32] installation of arc protection devices may be required by national regulations or technical rules to avoid arcs from burning off the covered conductors. However, the recommendations given in Latvian Energy Standard LEK 015 [28], Australian Ausgrid NS220 [6], as well as the Finnish and Norwegian technical recommendations [41] are not unambiguous. The frequency of arc protection device installation can be determined based on economic principles [26]. However, the effect of lightning discharge, and ambient and power line parameters on the frequency of arc protection device installation and the consequent damage to the power line must be considered first.

The methodologies are presented for the protection device installation by both the IEEE [23] and the Norwegian independent research organisation SINTEF [26], however, they neglect some factors, the main if them being the power line depreciation impact on the power line critical flashover voltage value and the lack of alternative analysis for a particular object, which allows one to quickly check how the power line parameters affect the power line faults and the resulting protection device placement frequency. Similarly, the methods are based on generally accepted average lightning current values that are assumed too high [13]. Therefore, it is necessary to look at the lightning strike statistics of a region, which include both the average lightning peak current values and the number of thunderstorm days per year.

The goal and the tasks solved by the Thesis

The goal of the Thesis is to develop a methodology for determining the frequency of lightning protection devices in medium voltage covered conductor overhead lines, based on

lightning caused flashover rate, the impact of power line depreciation and alternative analysis (other lightning current peak values and power line elements).

To achieve the goal, the following tasks were solved:

- 1) the most important parameters that influence the frequency of protection device placement were selected;
- 2) the analysis of lightning statistics of Latvia was made and the average thunderstorm day, T_d , map of Latvia was developed;
- 3) a computer simulation model for the lightning current modelling in covered conductor overhead lines has been developed;
- 4) shielding factor S_f value tables and curves for 3 different lightning current peak values, 7 different power line heights and 6 different nearby object heights were developed;
- 5) the structure of database for power line component critical flashover voltage values is offered for the analysis of alternatives by choosing different power line components;
- 6) it was evaluated how the power line depreciation affects the critical flashover voltage value and resulting flashover rate, and predicted power line critical flashover voltage reduction coefficient k_{CFO} curves were developed;
- 7) an algorithm to determine the frequency of protection device placement was developed.

Scientific novelty of the Thesis

The Thesis devised a methodology for determination of unambiguous frequency of placement of lightning protection devices in medium voltage overhead lines with covered conductors. Within the framework of the methodology the following tasks were carried out:

- 1) a new evaluation criterion is proposed – the frequency of the power line flashover ζ , the thresholds of which have been verified by assessing the influence of the different power line geographic, geometrical and electrical parameters;
- 2) the critical flashover voltage reduction coefficient k_{CFO} was developed, thus incorporating the forecast of power line depreciation in the proposed methodology;
- 3) the structure of data bases of critical flashover voltage values of power line elements was developed as well as relative cost analysis was performed, which allows the analysis of alternatives to be included in the proposed methodology.

In EMTP/ATP software a computer simulation model was developed for lightning strike simulation in medium voltage overhead line with covered conductors with or without protection devices, that allows analysing the lightning discharge processes in covered conductors as well as importance of placement of protection device installation.

Practical significance of the Thesis

The methodology developed in the Thesis 1) allows to calculate the number of medium voltage covered conductor overhead line damages caused by direct and indirect lightning strike, from which it is possible to obtain an unambiguous placement frequency of lightning protection devices; 2) helps to assess the influence of the power line depreciation on the power line fault rate, which allows to predict at the design stage after how many years the power line needs to be reviewed in order to rebuild or supplement it with additional protection devices to reduce the number of damages caused by lightning; 3) allows to easily apply the power line element database, which can be supplemented, to find out how replacement of insulator or covered conductor affects the obtained result.

Methodology of the research

The Thesis uses theoretical methods, statistical methods, probabilistic analysis and analysis of alternatives. Simulation of direct lightning strike in covered conductor overhead line using EMTP/ATP software and shielding factor calculation with collection surface method using AutoCAD software was performed.

Approbation of the Thesis

1. “Trends in lightning protection”. LEEA seminar for designers “From general principles to novelties in lightning protection designing”. Riga, Latvia, October 26, 2018.
2. “Methodology for optimal placement of lightning protection devices in medium voltage overhead lines with covered conductors”. 7th International Doctoral School of Electrical Energy Conversion and Saving Technologies. Ronisi, Latvia, May 25–26, 2018.
3. “Simulation of direct lightning strike in medium voltage covered conductor overhead line with arc protection device”. 58th International Conference on Power and Electrical Engineering of Riga Technical University (RTUCON). Latvia, Riga, October 12–13, 2017.
4. “Trends in lightning protection zone estimation”. Seminar at Elektrum Energy Efficiency Center. Jurmala, Latvia, October 26, 2016.
5. “Comparison of Commonly Used Mathematical Models for Lightning Return Stroke Current Waveform”. 13th International Conference of Young Scientists on Energy Issues. Lithuania, Kaunas, May 26–27, 2016.

Publications

1. Zimackis, V., Vitolina, S. Simulation of Direct Lightning Strike in Medium Voltage Covered Conductor Overhead Line with Arc Protection Device. 58th International Scientific Conference on Power and Electrical Engineering of Riga Technical University (RTUCON): Proceedings, Latvia, Riga, October 12–13, 2017. doi:10.1109/RTUCON.2017.8124820, **(IEEE, SCOPUS)**.
2. Sliskis, O., Vitolina, S., Ketners, K., Zimackis, V. Insulation Failures Flashover Rate Estimation for Metal Constructions in Overhead Transmission Lines. IEEE 58th International Scientific Conference on Power and Electrical Engineering of Riga Technical University (RTUCON): Proceedings, Latvia, Riga, October 12–13, 2017. doi:10.1109/RTUCON.2017.8124772, **(IEEE, SCOPUS)**.
3. Zimackis, V. Comparison of Commonly Used Mathematical Models for Lightning Return Stroke Current Waveform. 13th International Conference of Young Scientists on Energy Issues: Proceedings of CYSENI 2016, Lithuania, Kaunas, May 26–27, 2016. Kaunas: Lithuanian Energy Institute, 2016, pp. 123–130, ISSN 1822-7554.
4. Zimackis, V., Vitolina, S. Advancements in Building Lightning Protection Zone Estimation. 2015 IEEE 5th International Conference on Power Engineering, Energy and Electrical Drives (POWERENG): Proceedings, Latvia, Riga, May 11–13, 2015. pp. 211–214. doi:10.1109/PowerEng.2015.7266321, **(IEEE, SCOPUS)**.
5. Zimackis, V., Timmermanis, K. Ēku zibensnovēdēja aizsargzona un tās aplēses metodika. Enerģija un pasaule, 2014, Vol. 2, pp. 66–73. ISSN 1407-5911.

1. PLACEMENT OF PROTECTION DEVICES IN COVERED CONDUCTOR OVERHEAD LINES

Covered conductors consist of a conductor surrounded by a covering made of insulating material as protection against accidental contact with other covered conductors and with grounded parts such as tree branches, etc. In comparison with insulated conductors, this covering has reduced properties, therefore they must be treated as bare conductors with respect to electric shock [31].

Even though the cost of installing covered conductor overhead lines is somewhat higher than that of bare conductor overhead lines, the total cost of service is reduced. The main advantage of covered conductors is that the tree or branch of the tree that falls on the line does not cut off the power line, as in the case of a bare conductor overhead line, thus, the supply of electricity to the final consumer is not interrupted. Covered conductor overhead lines are more environmentally friendly, comparing the life cycle assessment and its environmental impact, the underground cable lines leave greater negative impact on the environment, since the cable lines are disconnected and unprocessed left in the soil. The total number of permanent faults of covered conductor lines is the lowest in comparison to bare conductors, covered conductors, aerial cables and underground cables [27].

The safety of people is another advantage of covered conductors as compared to bare conductor lines, accidentally touched overhead line by a crane or fishing rod, does not injure people if insulation is not damaged. Covered conductor overhead lines are also animal-friendly, birds, touching phase wires with wings are not exposed to electric shock.

For covered conductor overhead lines lightning protection is more important compared to bare conductor overhead lines. The direct or indirect lightning discharge results in overvoltage in the power line. Due to the insulation of covered conductor, the electric arc does not move and burns the hole in the insulation continuing to burn until the conductor is damaged or burned down. To avoid damage caused by electric arc, arc protection devices must be installed on covered conductor lines. Arc protection devices provide safe electric arc burning, while power line protection is activated, and the electric arc is extinguished [42], [40].

The following three types of arc protection devices are given in standard EN 50397-3 [32]: arc protection device (APD), power arc device (PAD) and a current-limiting arc horn (CLAH) or current limiting device. The simplest of the protective devices is the APD, which will redirect lightning caused electric arc from the insulator and covered conductor to APD with the supplied aluminium wire. To prevent insulator from damage at small short-circuit currents, it is possible to install a PAD that produces phase to phase short-circuit through a metal crossarm. If the power line is not equipped with a high-speed autoreclosure and it is essential to provide continuous power supply, it is recommended to install a CLAH consisting of a small metal oxide arrester (MO) and a spark gap, which means that the arrester does not work with power line overvoltages, therefore it is not required to change it so often. A comparison of arc protection devices is summarized in Table 1.1.

Too rarely placed arc protection devices will not perform their function, and it is not economically advantageous to place them too often, and too frequently placed arc protection devices may cause problems with power supply quality and subject to electric shock. Arc protection devices are not isolated, which means that too frequently placed protection devices

can adversely affect the advantages of covered conductor line in relation to bare conductor lines. Standard EN 50397-3 [32] states that the installation of arc protection devices may be required by national regulations or technical rules to avoid arcs from burning off the covered conductors. These requirements may also include additional information such as where such devices must be installed out for safety reasons, e.g. line ends, road crossings, places where the covering has been removed and angle poles. Guidance for the installation of protection devices is summarized in Table 1.2.

Table 1.1

Comparison of Arc Protection Devices

Parameter	Protection device type		
	APD	PAD	CLAH
Phase spacing, mm	<600	Any	Any
Short-circuit current, kA	1–3 ^a >3	Any	Any
Protection of other line components	No protection	Small power transformers	Small power transformers
Device endurance	2-3 times at 10 kA/s	2-3 times at 10 kA/s	May be damaged by lightning current
Insulator type	Pin and Post	Any	Any
Dependent of power flow direction	Yes	No	No
Earthed crossarm	No	No	Yes
Quality of power supply	High-speed autorecloser	High-speed autorecloser	No interruption

^a with double 25 mm² aluminium wire

Table 1.2

Arc Protection Installation Requirements in Different Countries

Country	Installation frequency	Additional information	Source
Latvia	Every 4th to 5th pole	In places where the power line is located parallel to the roads and sports tracks, as well as intersections with these places. In cities, villages and other densely populated areas Protection device type: PAD, APD	[34]
Norway and Finland	Every 3rd pole or 300 m	In exposed areas – at every pole. Places with high trees do not require protection devices. If there is no information, then – at every 2nd pole. Protection device type: PAD, APD	[52]
United Kingdom	Every 2 nd pole	Protection device type: PAD, APD	[53]
Australia	Every 4 th pole or 200–250 m.	In areas known to be prone to lightning strikes – at every pole. Protection device type: CLAH	[7]
Japan	Every pole	Protection device type: CLAH	[53]

For this reason, there is a need for a methodology for the placement of protection devices, so that there are no situations when the instructions can be interpreted differently. The frequency of arc protection device installation can be determined based on economical

principles [26]. However, the effect of lightning discharge, ambient and power line parameters on the frequency of arc protection device installation and the consequent damage to the power line must be considered first.

The methodology of IEEE 1410 has determined installation frequency of surge arresters in bare conductor overhead lines, however, changing the critical flashover voltage value of the power line, taking into account the characteristics of the covered conductor and by replacing the arrester discharge voltage level V_{IR} to the required arc protection device voltage that ignites electric arc, the methodology is applicable for determining the installation frequency of protection devices in covered conductor overhead lines [10].

If a direct lightning flash terminates at midspan between a pole with arresters and a pole without arresters, the first return stroke peak current in power line I_{ml} required to cause a flashover when the maximum value of overvoltage $V = V_{CFO}$ (see Chapter 4) is calculated as follows [23]:

$$I_{ml} = \frac{2ct_m(V_{CFO} - V_{IR})}{LZ_s}, \quad (1.1)$$

where V_{IR} is discharge voltage level, kV; L is separation distance to the next pole with arresters, m; c is the wave velocity ($3 \cdot 10^8$ m/s); Z_s is line surge impedance, Ω ; t_m is linear equivalent 0–100% front time, assumed to be $2 \mu\text{s}$ for the first return stroke.

A direct flash to a pole with phases not protected by arresters is assumed to flashover 100% of the time. A direct flash to a pole fully protected will not flashover, but the probability of flashover at the next unprotected pole still exists, which can be calculated as follows [23]:

$$I_{mb} = \frac{V_{CFO} - V_{IR}}{R_0}, \quad (1.2)$$

where R_0 is pole ground resistance, Ω . When calculating the peak current value in the power line required for flashover, using the expression (3.4), it is possible to calculate the probability of the first-stroke peak current that exceeds this current.

The methodology of Norwegian independent research organization SINTEF intends to calculate the probability of a flashover occurring in the place of a direct lightning strike, considering ground flash density, the frequency of protection device placement and the height of the trees near the power line. The SINTEF model assumes that flashover occurs either where lightning strikes or where the arc protection device is located. This methodology does not consider the flashovers from indirect lightning strike. The following factors are taken into account in the methodology:

- 1) statistical variation in the magnitude and steepness of lightning currents;
- 2) the mechanism for the occurrence of phase-to-phase arcing;
- 3) different types of arc protection devices;
- 4) spacing of arc protection devices;
- 5) location of points of impact of lightning relative to the arc protection devices;
- 6) whether the crossarm is grounded or not [26].

Reviewed methodologies for determining the placement frequency of protection devices are not complete because the methodology proposed by the IEEE-1410 does not directly take into account lightning statistics in a given region, nor does it show how the nearby objects affects the protection device placement frequency. In turn, SINTEF methodology does not take into

account the indirect flashovers from indirect lightning strike, which can be a decisive factor for the distribution power line. Given the fact that covered conductor overhead lines are often installed through the forest and the trees in the forest are usually higher than the overhead line, the number of direct lightning strikes is reduced, but the influence of indirect strike induced overvoltages increases. The trees near the power line during the rain increase the insulation flashovers of distribution line [37]. Neither of the two models offers alternative analysis, such as the use of other lightning peak current values, other insulators or pole types if the resultant deflection frequency is unsatisfactory, nor does it take into account the fact that critical flashover voltage of covered conductors deteriorates with years [8]. For this reason, in the methodology proposed by the author, the factors affecting the critical flashover voltage of the power line are summarized and used in analysis of alternatives. The proposed methodology is originally developed for Latvia, its simplified block diagram is shown in Fig. 1.1.

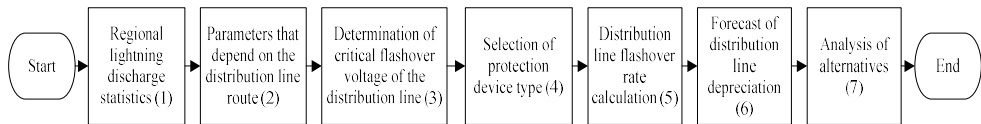

Fig. 1.1. Simplified block diagram of proposed methodology

2. LIGHTNING CURRENT AND ITS MATHEMATICAL MODELS

Lightning discharge is one of the natural phenomena that cannot be eliminated by any method or device, therefore it is important to identify and evaluate lightning discharge parameters that can have a dangerous effect. The damage caused by lightning can be significantly reduced by choosing the appropriate protection device. Using mathematical models, it is possible to simulate lightning current and its effect on the protected object, as a result, it is possible to choose the necessary insulation level of the power transmission line against overvoltages, as well as installation place and frequency of protection device.

Lightning current parameters have been studied since the middle of the 20th century and mostly derived from measurements taken in high objects. Lightning current usually consists of one or more components (first impulse current, subsequent impulse current or long-time current) [15].

Lightning current parameters have probable nature, the accepted values of each parameter are based on observations over the years, and in each region of the world these data may change, which once again proves how unpredictable is lightning.

Several mathematical models of lightning current are proposed, however, in order to be more widely applied, the lightning current mathematical model must fulfil the following requirements [19]:

- 1) a good approximation to the observed waveshape of the lightning;
- 2) enable the determination of the lightning current waveform parameters;
- 3) it should allow to change the maximum current steepness;
- 4) the current function should be differentiable in order to compute the lightning generated fields, besides no discontinuity should appear in first and second derivative;
- 5) it should be as simple as possible.

The first requirement that needs to be compared is the waveshape of the lightning current generated by the mathematical model and the one observed in nature. In the author's publication [44], lightning current mathematical models were examined by simulating the lightning discharge in the medium voltage distribution line, where the covered conductors were not yet used for lightning current simulation, in order to compare the obtained results with the ones found in literature.

Graphical comparison of lightning current waveshape obtained from lightning current mathematical models is shown in Fig. 2.1, a), but Fig. 2.1, b) shows the first negative lightning return stroke waveshape observed in the nature.

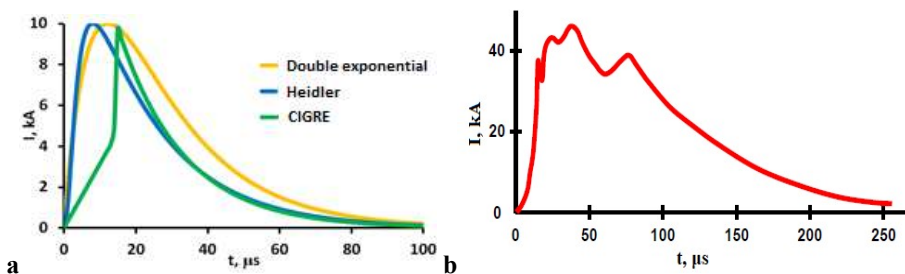

Fig. 2.1. Graphical comparison of lightning current waveshapes: a) lightning current waveshapes of mathematical models 10 kA, 8/20 μs ; b) the first negative lightning return stroke waveshape observed in the nature [20].

Comparing the curves in Fig. 2.1, we see that none of the mathematical models can completely represent the lightning current waveshape, because in nature it is not so smooth. In author's publication [44], comparing lightning current mathematical models to a distribution network, it can be observed that Heidler's mathematical model best describes a lightning current waveshape. The first derivative $(di/dt)_{t=0}$ of double exponential and CIGRE lightning current mathematical models is not zero, which means that the maximum lightning current steepness does not correspond to the one observed in nature. In addition, the double exponential model cannot be applied to short stroke currents, but the application of the CIGRE model is difficult, because the current waveshape is described with two expressions. Also, the lightning current parameters cannot be precisely adjusted to the lightning waveshape, because of their wide range. This once again proves the probable nature of lightning discharge and how difficult it is for engineers to predict its hazardous effect on the power line or any other object.

Considering the things mentioned above, to further to describe lightning current the Heidler mathematical model is used.

When the most suitable lightning current model is found, it is necessary to develop a model for lightning current simulation in covered conductor overhead line. To develop a complete simulation model of lightning strike in covered conductor, a lightning current simulation is performed in the MV power line with bare and covered conductors via the EMTP/ATP line and cable constant block LCC (Line / Cable Constant) with the JMarti model [33]. JMarti model operates in the frequency range from $5 \cdot 10^{-2}$ Hz to $5 \cdot 10^8$ Hz, taking into account the skin effect [4]. It is possible to use other models in LCC block, such as the PI model which is suitable for short power line simulation, however, the frequency dependent JMarti model is more accurate when propagation of lightning current is examined, but the calculation process is more time consuming.

In dissertation an arc protection device simulation model is developed (Fig. 2.2), where lightning strikes in the middle of the span between two medium voltage distribution line poles. The given model deals with variants when 1) the protection devices are installed on both poles, 2) without protection devices, 3) the protection device is installed on the pole located on the supply side, and 4) the protection device is installed on the pole located on the load side.

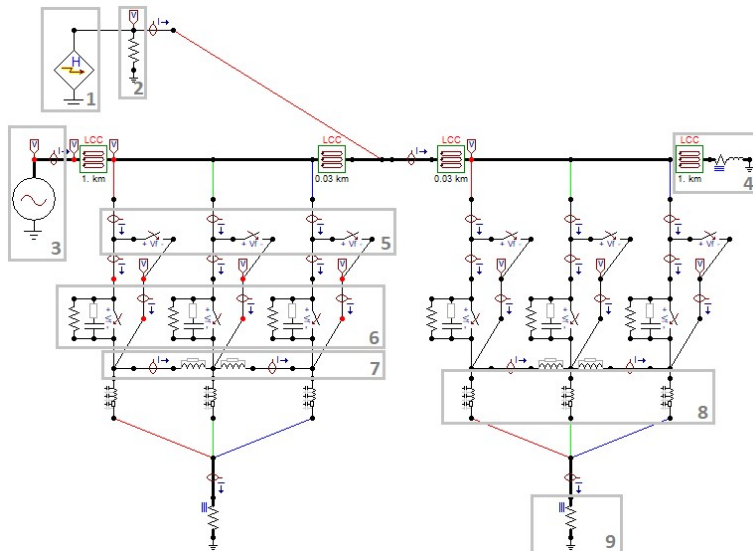

Fig. 2.2. EMTP/ATP simulation model of lightning strike in the span of medium voltage covered conductor distribution line.

- 1 – Heidler current source, 2 – lightning channel impedance, 3 – AC source, 4 – network load, 5 – power arc device, 6 – insulator, 7 – crossarm, 8 – wooden pole, 9 – grounding resistance.

To describe direct lightning strike, Heidler current source is used (Fig. 2.2, 1), with return stroke peak current $I_m = 3$ kA. According to IEC-62305-1 [15], to describe the first return stroke $\eta = 0.93$, $\tau_1 = 19$ μ s, $\tau_2 = 485$ μ s and $n = 10$. Lightning channel impedance (Fig. 2.2, 2) is represented as a parallel 400 Ω resistance [4]. Network voltage (Fig. 2.2, 3) is 20 kV at 50 Hz frequency. Network load (Fig. 2.2, 4) is represented as RL load equivalent to 250kVA transformer. Covered conductor was simulated using J. Marti frequency dependent LCC model, with span length given below each block. As covered conductor, CCXWK type conductor with 70 mm² cross section and conductor resistance 0.493 Ω /km are used. Power arc device (Fig. 2.2, 5) is represented as voltage-controlled switch between the phase conductor and crossarm with flashover voltage set to 180kV. The line insulators (Fig. 2.2, 6) are represented by parallel RC circuit between phase conductor and crossarm, where $R = 25$ M Ω and $C = 100$ pF (for suspension insulator $C = 80$ pF) [22]. Insulator flashover is simulated with parallel voltage-controlled switch set to 191.7 kV, which corresponds to the covered conductor power line critical flashover voltage. Metal crossarm (Fig. 2.2, 7) inductance $L_{ca} = 1$ μ H. The wooden poles are simulated using distributed parameters, described by the EMTP/ATP LINEZT_1 block (Fig. 2.2, 8), where pole resistance $Z_p = 295$ Ω /m, but the grounding resistance (Fig. 2.2, 9) for poles without grounding is assumed 1000 Ω [9].

In Fig. 2.3. the current values are given, when protection devices are installed on both poles and current distribution on the insulator and protection device of pole No. 2. As can be seen in Fig. 2.4, in order to flashover the current must exceed $I_{ml} = 4500$ A. At pole No. 2 or pole on

the load side this value is exceeded, resulting in a flashover, but at pole No. 1 this value is not exceeded, therefore there is no flashover. It is also clear that the arc has lit on the protection device rather than power line flashover, thus the covered conductor is not damaged. As a result, it is possible to check the current values at which there is distribution line flashover, according to calculations of presented in the 5th block of Fig. 1.1.

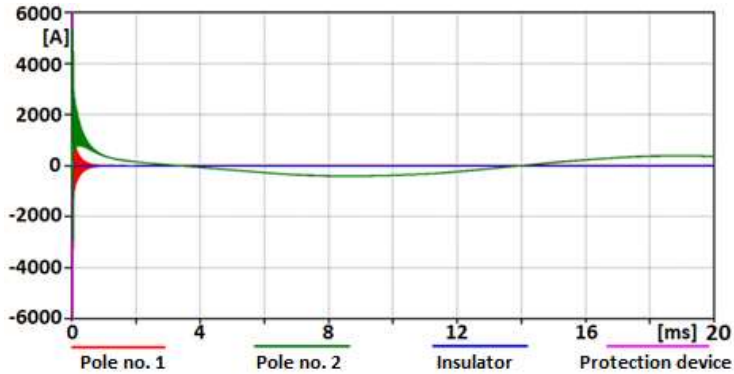

Fig. 2.3. Current values at the poles with protection device at each pole and current distribution on the insulator and protection device on pole No. 2.

3. DETERMINATION OF THE POINT OF STRIKE

3.1. Lightning incidence

One of the parameters that affects the protection device placement frequency is the ground flash density N_g , which is the number of flashes per km^2 per year. Ground flash density N_g can be determined from ground flash density maps, however, in many places, these maps are not available. Ground flash density may be estimated from keraunic level or the number of days with thunder per year T_d , or the number of thunderstorm hours per year T_h . For temperate areas (including Latvia) for the calculation of N_g , knowing T_d , it is recommended to use the following equation [23]:

$$N_g = 0.04T_d^{1.25}. \quad (3.1)$$

This equation has unacceptably large errors in tropical areas, so it is recommended to use equations derived from measurements in different regions. Small areas or areas with low T_d have a standard deviation of around 50%, which means that it takes several years to obtain accurate data.

When the ground flash density N_g is calculated, it is necessary to calculate the flash collection rate N in the distribution line, which is flashes per year per 1 km. Distribution lines are usually higher, so they are exposed to higher risk of lightning strike, especially if there are no adjacent buildings or trees. The expected flash collection rate N can be calculated by using the following formula:

$$N = \frac{K_o N_g (b + 10.5h_l^{0.75})}{1000}, \quad (3.2)$$

where K_o is orographic coefficient; b is width of distribution line, m; h_l is average height of the line, m. If the orographic condition is not known $K_o = 1,8$. By inserting this value in formula (3.2), we obtain a result that is comparable to that suggested by Eriksson [16] and the expression recommended by CIGRE [11] and IEEE [23]

$$N = \frac{N_g}{1000} (28h^{0.6} + b), \quad (3.3)$$

where h is height of the uppermost conductor at the pole, m.

To calculate flash collection rate in distribution line in the 1st block of the proposed methodology showed in Fig. 1.1, Equations (3.1) and (3.3) are used.

3.2. Lightning discharge statistics in Latvia

In order to calculate ground flash density N_g , it is necessary to find annual number of days with thunder T_d in Latvia. Within the framework of the Thesis unprocessed data from “Latvian Environment, Geology and Meteorology Centre” State Ltd. were extracted, these data included the following information: lightning discharge date, time, coordinates, estimated peak current value, number of strokes in a flash, accuracy and type of discharge (cloud to ground or cloud to cloud). From the obtained data, using statistical methods and MS Excel and AutoCAD software, the information was collected for each year and the calculated average values for the given period. More detailed consideration was given to cloud to ground discharge, because the discharge in the cloud does not cause dangerous overvoltages in the medium voltage power lines. During the period from 2006 to 2017, the current range is very wide, on average from 3.2 kA to 272.9 kA in the case of negative discharge and from 2.9 kA to 331.7 kA in the case of positive discharge. Negative lightning discharge is on average 86% of all cloud to ground flashes, so in further calculations, the positive lightning discharge values will not be considered. The average median value of negative polarity lightning current in Latvia is 16.4 kA, which in further work is used in calculations as a 50% probability current.

Summing up the lightning statistics in Latvia, the distribution curve is obtained (Fig. 3.1), which is characterized by Function [23]:

$$P(I_m \geq i_m) = \frac{1}{1 + \left(\frac{i_m}{16.4}\right)^{2.6}}. \quad (3.4)$$

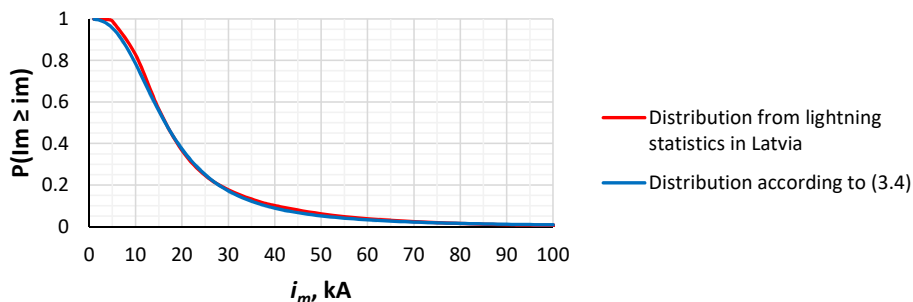

Fig. 3.1. Distribution of lightning peak current in Latvia

The given IEEE 1410 curves have the following flaws that prevent them from being easily applied in practice: shielding factor Sf values are given only for a 10 m high distribution line only at the generally accepted mean return stroke peak current $I_m = 31$ kA.

The impact of nearby objects on the direct lightning and shielding factor Sf is influenced by several factors such as:

- 1) return stroke peak current I_m ;
- 2) average height of the line h_l ;
- 3) width of distribution line b ;
- 4) height of nearby objects h_k ;
- 5) distance of nearby objects from the line s_k ;
- 6) width of nearby objects;
- 7) striking distance r_{sd} .

The proposed methodology considers the Sf obtained from the three return stroke peak current values, taking into account the distribution of the maximum power of lightning current in Latvia (Fig. 3.1). Probabilities of 10 %, 50 % and 90 % were used, corresponding to 38.2 kA, 16.4 kA and 7.0 kA, respectively.

The power line heights are taken from the heights offered by LEK 120 [29] for 20 kV power line wooden poles for covered conductors. When looking at all possible pole types, the power line height, rounded up to whole meters, ranges from 7 m to 13 m above the ground.

The width of the power line is in the range from ~0.65 m to ~2.5 m. After calculations for limit values of the given b range were made, it was concluded that Sf value is affected only by 1–2 %. So, in order to make application of Sf more practicable, in the following calculations one power line width, $b = 0,8$ m, is used, which is the width of the pole S20.I- HT [29].

7 alternatives are available of the height of the nearby objects: 0/3, 1/3, 2/3, 3/3, 4/3, 5/3 and 6/3 of the power line height h_l . Heights are offered as part of the power line height, because when looking at trees or other objects nearby power line, it is more convenient to determine the height of the object in proportion to the height of the power line, rather than the specific units of measurement.

The range of the distance of objects from the line is from 2.5 m to 80 m, with an emphasis on the 2.5 m and 6.5 m mark, which, according to the Protection Zone Law [3], is the width of the route of power lines in settlements, towns and villages, and outside settlements, towns and villages, as well as forest areas, respectively.

The width of nearby objects for practical reasons will not be considered, because in the case of woodland next to power line, Sf is slightly higher than in the case of a standalone tree. Therefore, for further calculations it is assumed that the nearby objects are located parallel to the power line in a steady, straight line.

Striking distance r_{sd} is assumed to be the same for both discharge to ground and discharge to power line, since the height of distribution lines is low when compared to transmission lines. For further calculations striking distance

$$r_{sd} = 10I_m^{0.65}. \quad (3.7)$$

A collection surface method [17] is used to determine the shielding factor Sf . Initially, the length l_l of arc formed by collection surface, in the case where power line is in open field, is determined. Then, it is necessary to define how much of the power line's collection surface is

covered by the collection surface of the nearby object, and the length l_2 of the unshielded collection surface is determined. When both arc lengths l_1 and l_2 are determined, it is possible to calculate the shielding factor:

$$Sf = 1 - \frac{l_2}{l_1}. \quad (3.8)$$

Calculated shielding factors Sf for power line with a height $h_l = 10$ m and return stroke peak current $I_m = 16.4$ kA as curves are given in Fig. 3.3. When shielding factor Sf values are obtained, it is possible to calculate collection rate of the shielded power line N_s by using Equation (3.5) or (3.6).

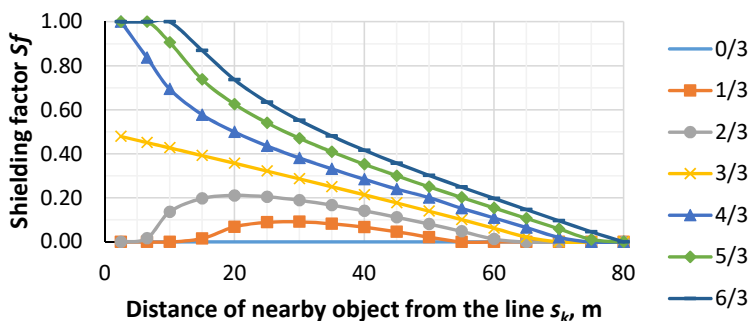

Fig. 3.3. Shielding factor Sf as the function of distance of nearby object from the line s_k when $h_l = 10$ m and $I_m = 16,4$ kA

From the given curve it can be seen that as the height of object h_k increases, the value of Sf also increases and as the distance from the power line s_k increases, the value of the Sf decreases. If the height of the object nearby power line is equal to the power line height, $h_k = h_l$, the shielding factor value changes linearly. When $h_k < h_l$, then the value of Sf at the beginning increases as the distance from the power line s_k increases, and only then decreases.

4. OVERVOLTAGES IN MEDIUM VOLTAGE NETWORK

4.1. Direct and indirect lightning strike caused overvoltages

The total distribution line insulation flashover rate F caused by direct and indirect lightning strike is the sum of both flashover rates [34]:

$$F = F_d + F_p, \quad (4.1)$$

where F_d is flashover rate from direct lightning strike, flashovers/km/year; F_p is flashover rate from indirect lightning strike, flashovers/km/year.

A general representation of lightning caused overvoltages in power line is given in Fig. 4.1, where y_{min} is the distance from power line to which power line is exposed only to direct lightning strike, but y_{max} is distance from power line to which power line is exposed to direct and indirect

lightning induced overvoltages, if peak value of induced voltage is greater than or equal to power line critical flashover voltage V_{CFO} .

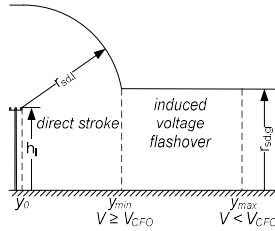

Fig. 4.1. General representation of lightning caused overvoltages in power line.

The flashover rate of an overhead power line due to direct lightning strike is given as [34]

$$F_d = N \int_{I_F}^{\infty} f(I) dI, \quad (4.2)$$

where

$$f(I) = \frac{1}{\sqrt{2\pi}\beta I} \exp\left[-\frac{(\ln I - \ln \bar{I})^2}{2\beta^2}\right], \quad (4.3)$$

where β is standard deviation of the natural logarithm; \bar{I} is return stroke peak current median value.

Due to the relatively low V_{CFO} of the medium voltage power lines, it can be assumed that the integral (4.2) value for power lines without protection is approximately 1, therefore, $F_d \approx N$ [34]. It means that the number of direct lightning strike caused flashovers in an open field can be calculated using Formula (3.3), but for the power line with nearby objects Formula (3.5) or (3.6).

Lightning discharge to ground or to object nearby power line induces a voltage, which can significantly exceed the nominal power line voltage and even the V_{CFO} value, causing insulation flashover as in the case of direct lightning strike.

The insulation flashover rate of an overhead power line due to induced voltages caused by nearby lightning strokes can be expressed as [23]

$$F_p = 2N_g 0,1 \sum_{i=1}^{200} P_i (y_{i\max} - y_{i\min}). \quad (4.4)$$

The minimum distance y_{\min} for which lightning will not divert to the line, is calculated [23] as follows:

$$y_{\min} = \sqrt{r_{sd,l}^2 - (r_{sd,g} - h_l)^2}. \quad (4.5)$$

Striking distance from power line $r_{sd,l}$ and from ground $r_{sd,g}$ is calculated by Equation (3.7).

To calculate the maximum distance y_{\max} from the power line to which the power line is subjected to direct and indirect lightning overvoltages, it is necessary to calculate the induced overvoltage which is greater than or equal to the V_{CFO} , which is 1.5 times the power line insulation critical flashover voltage at standard lightning impulse (1.2/50 μ s) and under standard atmospheric conditions [23].

The Swedish engineer Sune Rusck [39] for the description of return stroke and coupling model proposed to express the total electric field on the conductor surface in relation to scalar and vector potentials.

Rusck also proposed a simplified formula that can be used for approximate estimation of induced overvoltage peak value [23]:

$$U_m = Z_0 \frac{k_v h_l I_m}{y}, \quad (4.6)$$

where Z_0 is surge impedance, Ω ; k_v is return stroke velocity characterizing coefficient.

One of the limitations of the Rusck simplified formula is that it can be applied only to a case of ideal ground conductivity, which can be effectively eliminated by artificially increasing the height of the power line. Australian scientist Mat Darveniza suggests to replace the height of the power line h_l in Equation (4.6) with effective height of the conductor h_{ef} , which integrates ground resistance ρ in the height of the power line [14]

$$h_{ef} = h_l + 0.15\sqrt{\rho}. \quad (4.7)$$

Indian scientist Ashok K. Agrawal with colleagues [2] proposes to integrate Maxwell's equations into return stroke and coupling models and as a result express the equations in terms of scattered voltage. The Agrawal model is also implemented into a widely used computer code LIOV (lightning induced overvoltage code) [30], which allows calculations of multi-conductor overhead power lines at different ground conductivity, considering the geometric parameters of the power line, the lightning current waveform, return stroke velocity, etc. The use of the LIOV code for calculations is also approved by IEEE [23] and CIGRE, furthermore, the result obtained using LIOV is considered as the reference value for lightning induced overvoltage estimation [30]. In order to avoid complicated calculations of the electromagnetic field, using a multiple dispersion analysis, a Macedonian scientist Voislav Jankov proposes an approximated equation for calculating the induced overvoltage peak value [24].

In previous comparisons, it was observed that when ground resistance increases, the lightning induced overvoltage value also increases. If ground resistivity $\rho = 100 \Omega/m$ and $1000 \Omega/m$, then the difference is 13 % and 32 %, respectively. A similar error was found when Rusck's simplified formula was compared to Agrawal's model. Rusck's simplified formula (4.6) with sufficiently high accuracy, can be used to calculate the lightning induced overvoltage peak value, if the power line height h_l is replaced by the effective height of conductor h_{ef} , according to Expression (4.7). In the framework of proposed methodology, a simplified Rusck's formula (4.6) is used to calculate the indirect lightning induced overvoltage peak value, replacing the power line height h_l with the effective height of conductor h_{ef} (4.7).

4.2. Critical flashover voltage of medium voltage overhead lines with covered conductors

The electrical strength of insulation can be expressed by several principles, such as basic lightning insulation level (BIL), basic switching impulse insulation level (BSL) or critical flashover voltage (CFO) [21].

Within the proposed methodology it is assumed that the given CFO values are at standard atmospheric conditions and therefore are not corrected.

Power lines usually consist of several insulation components such as porcelain, composite materials and air. Each component has its own insulation strength. When the insulating materials are used in series, their total insulation is not equal to the sum of the CFO of all individual components. Usually it is less – about 60–80 % of that sum [43]. As the laboratory data became available, various methods were studied to develop a procedure for use in determining the expected CFO of a given combination of insulating components. The “insulation-strength-added” is one of approaches [23]. This method takes into account the contribution of each CFO of added elements to the total power line CFO, keeping in mind that the added insulation strength is always less than that of the single added element. The CFO of the second additional component can be written as follows:

$$CFO_{add.sec} = 0.45CFO_{ins}, \quad (4.8)$$

where CFO_{ins} is CFO of the primary insulation, kV. The CFO of the third and each of the next added component is as follows:

$$CFO_{add.third} = 0.2CFO_{ins}, \quad (4.9)$$

but the total critical flashover voltage of power line insulation can be expressed as follows:

$$CFO_T = CFO_{ins} + CFO_{add.sec} + CFO_{add.third} + \dots + CFO_{add.n}. \quad (4.10)$$

The insulation-strength-added method usually gives results within a 20 % error, for more accurate CFO results laboratory impulse tests must be performed. When performing impulse tests under dry conditions, the obtained CFO needs to be multiplied by 0.8 to estimate the CFO for wet conditions [23].

There are several possible flashover paths for the power line, such as covered conductor and insulator or covered conductor and air. Therefore, it is important to identify all possible flashover paths and, for future calculations, use the lowest CFO value of power line insulation. The CFO values for various power line components are summarized in Table 4.1, creating a database structure for CFO values for the power line components, which can be supplemented.

The value of power line CFO is important because for greater CFO flashover occurs less frequently. By increasing CFO of the power line by 50 kV (for example, from 170 kV to 220 kV), the damage can be reduced by 13 %, but by increasing it by 100 kV, the decrease is 27 % [35]. The effect of estimated power line CFO on the probability (3.4) of the first stroke peak current I_m that exceeds current I_{ml} (1.2) required to cause flashover is given in Fig. 4.2, if a protection device is installed on every 4th pole or every 240 m. Figure 4.2 also shows that distance y_{max} from the power line to which the power line is subjected to direct and indirect lightning overvoltages, significantly decreases with increasing power line CFO. In the calculation, it is assumed that the height of the power line, or the effective height of conductor h_{ef} ($\rho = 0$) = h_l = 10 m, return stroke peak current value $I_m = 16.4$ kA, surge impedance $Z_0 = 30 \Omega$, and return stroke velocity characterizing coefficient $k_v = 1.29$.

Table 4.1

Database Structure for Minimal CFO Values of Various Power Line Components

Insulator type	kV	Covering of covered conductor	kV
Pin insulator SDI37 [40]	125	XLPE 2.3 mm [26]	92
Pin insulator SDI30 [40]	125	XLPE 3.1 mm [35]	130
Suspension insulator SDI90.150 [40]	126	HDPE 3.9 mm [35]	221
Suspension insulator SDI90.280 [40]	171	...	
Suspension insulator LK-70/20-III [12]	125		
Suspension insulator LK-70/20-VII [12]	135		
...			
Insulating material	kV/m	Type of protection device	V_{IR} , kV
Air [23]	600	APD	same as insulator CFO
Wooden pole [23]	330	PAD (100 mm) [26]	120
...		PAD (150 mm) [26]	180
		CLAH [18]	70
		...	

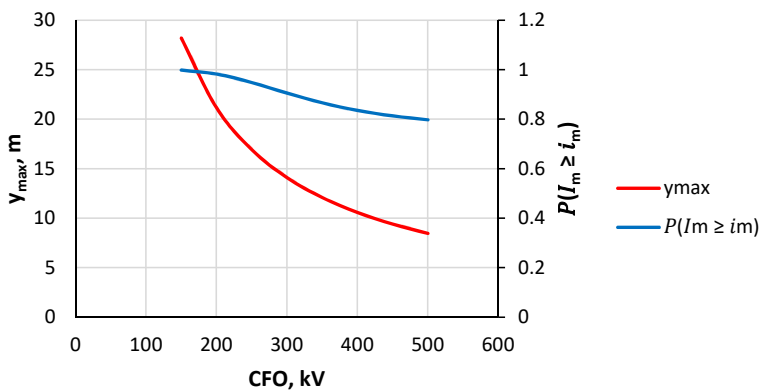

Fig.4.2. The effect of estimated power line CFO on probability of the first stroke peak current I_m that exceeds the value required to cause flashover, and on distance y_{max} to which the power line is subjected to direct and indirect lightning overvoltages.

4.2. The influence of the covered conductor depreciation on the CFO

The initial calculations generally consider the characteristics of the new power line components and do not take into account that the power line lifetime is several decades, which means that the power line CFO may decrease due to weather conditions, the environment or some other reason, which is showed in the 6th block of Fig. 1.1.

It is important to choose the appropriate components of the power line, considering environmental factors, for example improperly selected insulator or bad contact even at 20 kV can create high frequency voltages that may damage the covering of the covered conductor [38]. Therefore, it is necessary to look at the main factors that affect the reduction of power line CFO.

1. Damaged covered conductor;
2. Pollution of the environment;
3. Depreciation of covered conductor.

During operational time, the CFO of covered conductor power line may significantly decrease. Covering damage reduces the CFO by about 6 %, environmental pollution – by about 30–40 % depending on the insulator type, but conductor’s thermal and electrical wear – by as much as 50 %, although no significant CFO reduction is seen in the first 5 years.

It has been shown experimentally that the lifetime of an isolated cable is 20–30 years [36]. Within the proposed methodology, the power line depreciation forecast covers a 30-year operational time. Considering the influence of the mentioned factors on the power line CFO, the bathtub curve principle is used to describe predicted depreciation effect on the power line CFO, which is defined as the predicted power line CFO reduction coefficient k_{CFO} .

Three types of impact of environmental pollution are proposed, which are presented as the examples of typical environments in the Annex of the Doctoral Thesis. The impact of light pollution can be seen in example E2, the impact of medium pollution in E3 and E4, but the impact of heavy pollution in E5, E6 and E7. In the case of light pollution, the insulator's CFO gradually decreases by 10 %, in the case of medium pollution by 20 %, and in the case of heavy pollution by 30 %. After 20 years of operation, pollution has reached its peak and is no longer affecting the insulator's CFO. The impact of very light pollution of environment on the CFO power line insulator is not considered for example E1.

It is assumed that various non-operational damages, such as defects in the production, transport and assembly of covered conductor power line (including covering damage), reduce the covered conductor CFO by 5 %.

According to previous studies [36], [8], it is expected that the impact of covered conductor depreciation is negligible for the first 20 years of operation, but the CFO after 20 years of operation decreases by 30 % over the next 10 years and does not change after that.

Predicted power line CFO reduction coefficient k_{CFO} values developed within the Doctoral Thesis are given in Fig. 4.3.

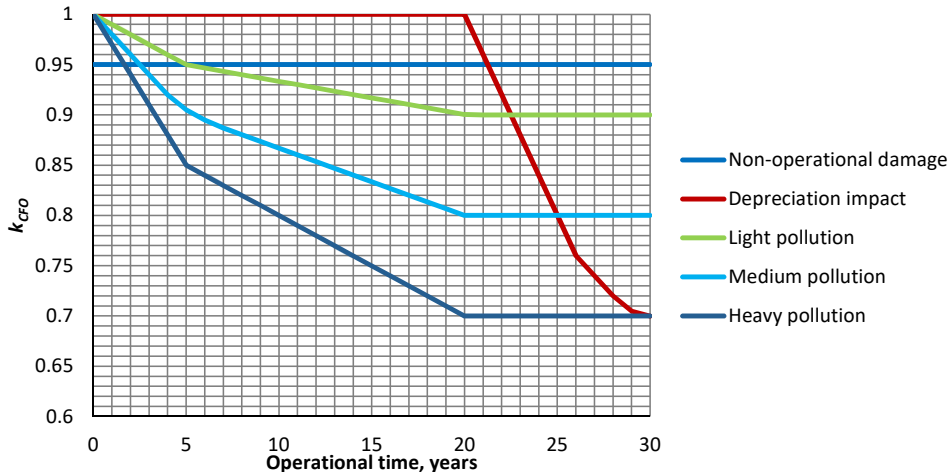

Fig. 4.3. Curves of predicted power line CFO reduction coefficient k_{CFO} .

In order to estimate the influence of depreciation of the power line on the protection device placement frequency, the proposed methodology is intended to re-calculate the lightning caused flashover rate for each operational period of 5 years using the predicted power line component CFO:

$$CFO_i = k_{CFO} CFO. \quad (4.11)$$

5. PROPOSED ALGORITHM FOR EVALUATION OF LIGHTNING PROTECTION DEVICES PLACEMENT FREQUENCY

5.1. Suggested criteria for placement of covered conductor lightning protection devices

As mentioned in Chapter 1, when direct or indirect lightning discharge occurs, an overvoltage arises in the power line, resulting in an electrical arc between the phases that may damage the covering of the covered conductor. In order to prevent covering damage, installation of arc protection devices in medium voltage overhead lines with covered conductors is necessary. Existing methodologies, as the criterion for the placement of protection devices, uses only the distribution line insulation flashover rate F , however, for unambiguous placement frequency estimation it is insufficient.

The proposed methodology for estimation of protection device placement frequency is based on the following criteria:

- 1) the total distribution line insulation flashover rate F ;
- 2) the frequency of the distribution line flashover $\zeta = 1/F$;
- 3) the predicted effect of covered conductor distribution line depreciation on the flashover rate and frequency of the distribution line flashover;
- 4) analysis of alternatives.

In the proposed methodology, the protection device placement frequency is influenced by the following factors and calculation parameters:

- 1) lightning discharge statistics in the given region, which include the number of days with thunder and the distribution of lightning peak current;
- 2) the height and distance from the power lines of nearby objects (trees, structures, etc.);
- 3) power line CFO, which also includes an analysis of possible flashover paths.

With the proposed methodology, the power line flashover rate is obtained from both direct and indirect lightning discharge, from which the frequency of the distribution line flashover ζ is calculated, which serves as a criterion for assessing the protection device placement frequency. The ζ limit values proposed by the author in the methodology for assessing the protection device placement frequency are given in Table 5.1.

With analysis of alternatives, it is possible to choose another component of power line or power line pole by comparing relative costs.

The proposed methodology does not take into account the effect on the protection device placement frequency of existing pole-mounted equipment and its protection, the crossings with

another overhead communications, and the case where the low voltage line and the medium voltage line are mounted on common poles.

Table 5.1

Protection Device Placement Frequency Depending on ζ

Number of spans	ζ , years/km
1	≤ 3
2	$3 < \zeta \leq 6$
3	$6 < \zeta \leq 9$
4	$9 < \zeta \leq 20$
5	$20 < \zeta \leq 30$
Without protection devices	> 30

All assumptions of the proposed methodology relate to the assumptions of the formulas and methods used in the calculation of required parameters. For ground flash density N , flash collection rate N_g , return stroke peak current in power line required to cause a flashover I_{ml} , return stroke peak current in power line pole required to cause a flashover I_{mb} and the insulation flashover rate of an overhead power line due to induced voltages F_p calculation equations from IEEE 1410 [23] methodology and Rusck's simplified formula [39] with Darveniza's proposed effective height of conductor h_{ef} [14] are used. The collection surface method is used to determine the shielding factor [17].

5.2. Structure of algorithm

Simplified block diagram of the proposed methodology for protection device placement is given in Fig. 1.1, but the expanded block diagram is given in Fig. 5.1. The algorithm is divided into 7 blocks, which can be subdivided into fixed parts and variable parts. The fixed parts of the algorithm include the lightning discharge statistics of particular region, and predicted power line CFO reduction coefficient.

The variable parts of the algorithm include the following.

1. Parameters that depend on the distribution line route. Shielding factor Sf is influenced by the return stroke peak current, therefore, it is proposed to analyse three possible variants of the return stroke peak current with a probability of 10 %, 50 % and 90 %, which in Latvia corresponds to 7.0 kA, 16.4 kA and 38.2 kA, respectively.
2. Determination of distribution line CFO. Type and thickness of covered conductor's covering, as well as insulator type affects the power line CFO.
3. Selection of protection device type, different discharge voltage level V_{IR} .
4. Distribution line flashover rate calculation is affected by the parameters mentioned before.
5. Analysis of alternatives, where the influence of variable parameters on the protection device placement frequency is considered.

The characteristics of the block diagram (Fig. 5.1), which are necessary for the determination of power line section types, can be obtained by examining the route of the power line to be reconstructed and performing the necessary measurements, for example, the ground resistance ρ .

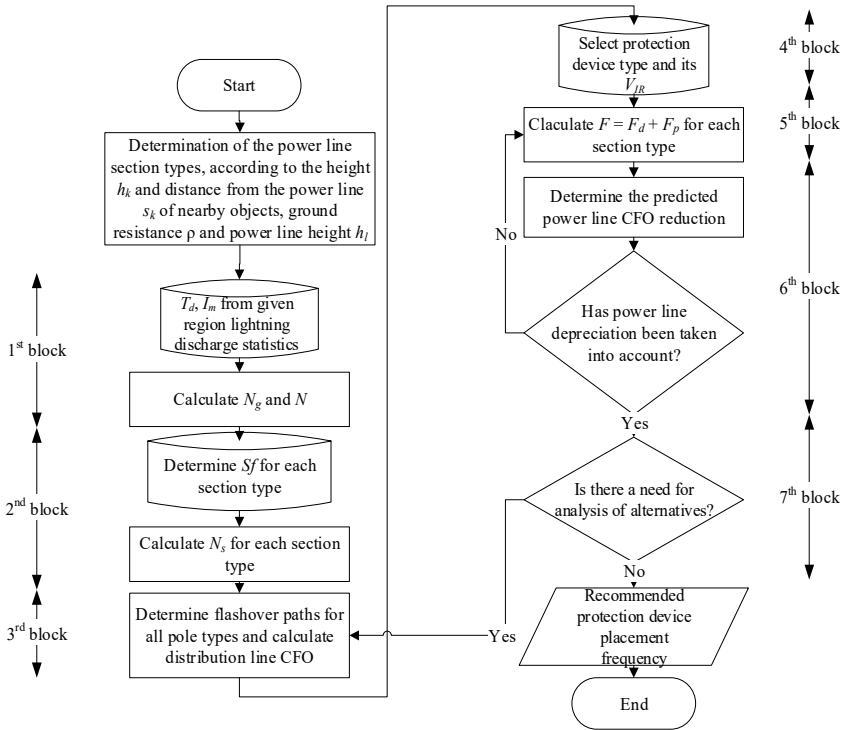

Fig. 5.1. Expanded block diagram of proposed methodology for estimation of protection device placement frequency.

As a result of the proposed methodology, the user obtains the recommended protection device placement frequency for the power line in question. The proposed methodology can be used both at the project stage and for in-service covered conductor overhead lines.

5.3. Extended explanation of methodology and application example

The flowchart of power line section type determination is given in Fig. 5.2.

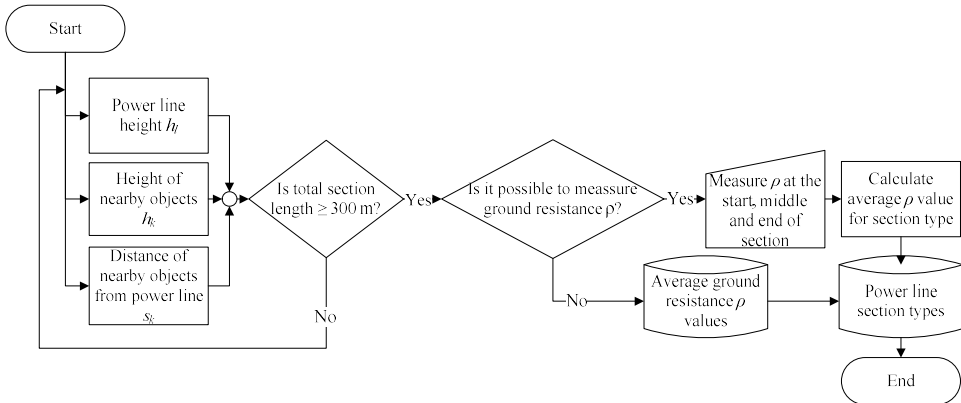

Fig. 5.2. Flowchart of power line section type determination.

When the initial measurements and calculations are made, the power line to be reconstructed is divided into section types. The total number of possible section types is very large, since the proposed methodology provides 7 different power line heights h_l , 7 different heights of nearby objects h_k , 17 different distances of nearby objects from power line s_k , which can be both on one side and on both sides of the power line. When dividing power line into section types, it should be taken in consideration that the length of the section type must be at least 300 m in order to be considered as a separate type. If the length of the section is less than 300 m, then it is added to the section type with the closest selection criteria.

From Latvian map of average number of days with thunder T_d (Fig. 3.2.), the annual number of days with thunder for region where power line is located is determined. Next step is to calculate ground flash density N_g using Expression (3.1). After that the power line flash collection rate for each section type is calculated using Expression (3.3).

When power line flash collection rate N is calculated, it is necessary to look how objects nearby power line influence this value. To do this, shielding factor Sf for each section type is determined and the shielded power line flash collection rate N_s is calculated using Equation (3.5) or (3.6), depending on whether the objects are on one or both sides of the power line.

In application example, intermediate poles have SDI30 type insulators, anchor poles – SDI90.150 type insulators, but the covered conductor has XLPE 2.3 mm covering. The minimum CFO values for these power line components are given in Table 4.1. Power line consists of several insulating materials, so it is important to identify all possible flashover paths and for further calculations use the smallest CFO_T value, which is calculated using Formulas (4.8), (4.9) and (4.10).

Next step is to select the protection device type, taking relative costs as primary criterion, see Table 5.2. Initially the protection device with the lowest relative costs is chosen, if it meets the requirements given in Table 1.1, from database in Table 4.1, V_{IR} is determined.

Table 5.2

Relative Costs of Protection Device

Protection device type	Relative costs
APD	1.0
PAD	1.4
CLAH	7.3

The flowchart of power line flashover rate F calculation is given in Fig. 5.3. The calculation must be done for each section type and probable lightning peak current, according to distribution (3.4), separately. Flashover rate from direct lightning strike F_d is calculated by multiplying the N_s of each section type by probability of a lightning peak current that exceeds value required to cause flashover using equation

$$F_{dj} = N_s \left(\frac{P_{ml}}{j} + \frac{P_{mb}}{2j} + \frac{2j-3}{2j} \right), \quad (5.1)$$

where P_{ml} is the probability that the lightning peak current will exceed the calculated current in the power line I_{ml} ; P_{mb} is the probability that the lightning peak current will exceed the calculated current in the pole of power line; j is the number of spans between protection devices.

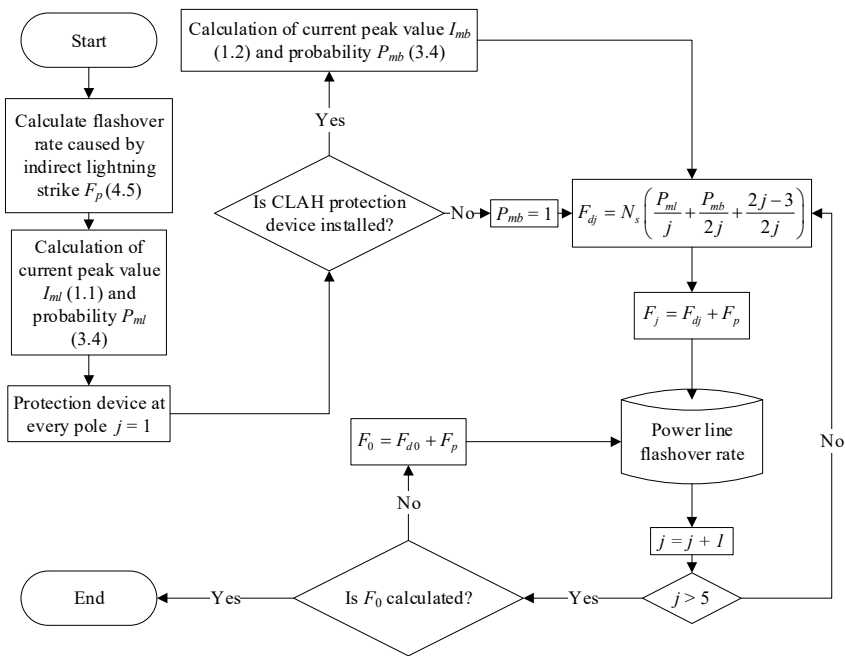

Fig. 5.3. Flowchart of power line flashover rate calculation

Using Formula (4.1) the total distribution line flashover rate F is calculated, from which it is possible to calculate the frequency of the distribution line flashover ζ . It is introduced to link the power line flashover rate with the operational time in years of the power line that is the basis for the power line depreciation prediction.

During the operation time of the power line, the power line CFO is reduced. The impact of the predicted power line depreciation is the second criterion for determining the protection device placement frequency. The flowchart of estimation of the effect of the predicted power line depreciation on the protection device placement frequency is given in Fig. 5.4. The effect of power line depreciation can also be estimated for the in-service covered conductor overhead line, if its installation year and the initial power line CFO is known.

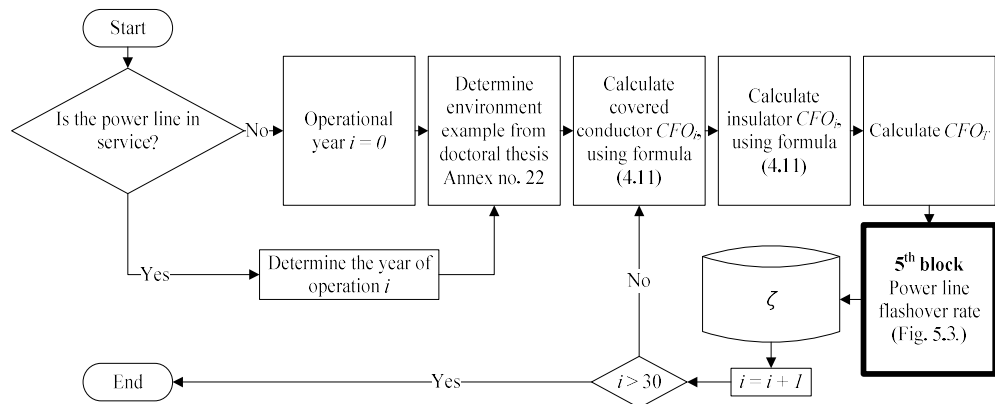

Fig. 5.4. Flowchart of estimation of the effect of the predicted power line depreciation.

Flowchart of the analysis of alternatives, which is the third criterion for determining the protection device placement frequency, is given in Fig. 5.5.

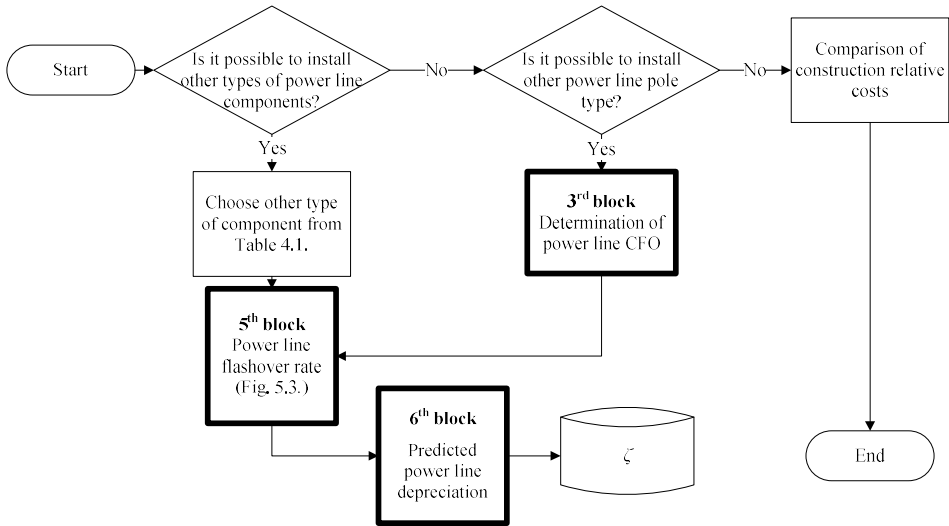

Fig. 5.5. Flowchart of analysis of alternatives.

Let us look at the application of the proposed methodology with an example of a 20 kV overhead line with a route typical to Latvia (Fig. 5.6.), which according to flowchart in Fig. 5.2. can be divided into 3 section types.

Type 1: $h_l = 8$ m, $h_k = 6$ m, power line crosses the forest area where it is necessary to clear the route in accordance with the Protection Zone Law [3], which is 6.5 m to each side from the power line axis, thus $s_k = 6.5$ m. The total length of this section type is 2 km;

Type 2: $h_l = 10$ m, power line crosses an open field where the nearest trees are 100 m from the power line, therefore their shielding impact can be ignored. The total length of this section type is 2.6 km.

Type 3: $h_l = 10$ m, on one side $s_k = 40$ m from the power line there are trees with height $h_k = 20$ m. The total length of this section is 1.8 km.

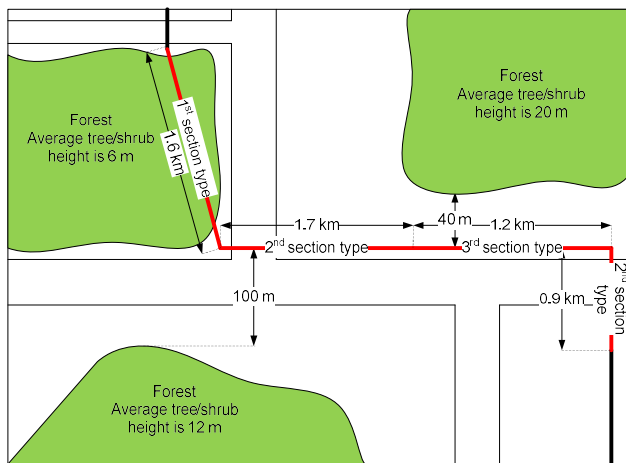

Fig. 5.6. Schematic representation of the power line to be reconstructed.

Table 5.3

Total Power Line Flashover Rate and Frequency of the Power Line Flashover

		Spans between protection devices	F , flashovers/km/year			ζ , years/km		
			No. 1	No. 2	No. 3	No. 1	No. 2	No. 3
Probability of return stroke peak current I_m	90 %	1	0.119	0.183	0.135	8.4	5.5	7.4
		2	0.121	0.186	0.138	8.3	5.4	7.3
		3	0.121	0.187	0.139	8.2	5.3	7.2
		4	0.122	0.188	0.139	8.2	5.3	7.2
		5	0.122	0.188	0.139	8.2	5.3	7.2
		Without protection devices	0.123	0.189	0.14	8.2	5.3	7.1
	50 %	1	0.144	0.183	0.106	6.9	5.5	9.4
		2	0.147	0.186	0.108	6.8	5.4	9.3
		3	0.148	0.187	0.109	6.8	5.3	9.2
		4	0.148	0.188	0.109	6.8	5.3	9.2
		5	0.148	0.188	0.109	6.7	5.3	9.2
		Without protection devices	0.149	0.189	0.11	6.7	5.3	9.1
	10 %	1	0.16	0.183	0.081	6.2	5.5	12.4
		2	0.163	0.186	0.082	6.1	5.4	12.2
		3	0.164	0.187	0.082	6.1	5.3	12.1
		4	0.164	0.188	0.083	6.1	5.3	12.1
		5	0.165	0.188	0.083	6.1	5.3	12.1
		Without protection devices	0.166	0.189	0.083	6.0	5.3	12.0

Table 5.4

Impact of Power Line Depreciation on ζ with 50 % Return Stroke Peak Current Probability

		Spans between protection devices	ζ , years/km						
			0	5	10	15	20	25	30
Section type	No. 1	1	6.9	6.9	6.9	6.8	6.8	3.7	2.4
		2	6.8	6.8	6.8	6.8	6.8	3.7	2.4
		3	6.8	6.8	6.8	6.8	6.7	3.7	2.4
		4	6.7	6.7	6.7	6.7	6.7	3.7	2.4
		5	6.7	6.7	6.7	6.7	6.7	3.7	2.4
		Without protection devices	6.7	6.7	6.7	6.7	6.7	3.7	2.4
	No. 2	1	5.4	5.4	5.0	4.5	4.1	1.9	1.4
		2	5.4	5.3	4.9	4.5	4.1	1.9	1.4
		3	5.3	5.3	4.9	4.5	4.1	1.8	1.4
		4	5.3	5.3	4.9	4.4	4.1	1.8	1.4
		5	5.3	5.3	4.9	4.4	4.1	1.8	1.4
		Without protection devices	5.3	5.3	4.9	4.4	4.1	1.8	1.4
	No. 3	1	9.4	9.3	8.1	6.9	6.1	2.2	1.6
		2	9.2	9.2	8.0	6.9	6.1	2.2	1.6
		3	9.2	9.2	8.0	6.9	6.0	2.2	1.6
		4	9.2	9.2	8.0	6.9	6.0	2.2	1.6
		5	9.2	9.1	8.0	6.9	6.0	2.2	1.6
		Without protection devices	9.1	9.1	7.9	6.8	6.0	2.2	1.6

The power line given in the example is fictional and does not exist, so it is not possible to measure ground resistance ρ . About 20–30 % of the territory of Latvia is sandy soil, therefore it is assumed that in all sections given in this example ground resistance $\rho = 100 \text{ } \Omega \cdot \text{m}$ corresponding to a sandy soil [25].

The total power line flashover rate F and frequency of the power line flashover ζ of the given example, without taking into account depreciation of the power line and analysis of alternatives, are summarized in Table 5.3.

The next step is to calculate the total power line flashover rate using the flowchart of estimation of the effect of the predicted power line depreciation given in Fig. 5.4 and frequency of the power line flashover ζ . Calculations are made for each section type of power line. The effect of the power line depreciation on ζ is summarized in Table 5.4.

The recommended protection device placement frequency and the result obtained with different return stroke peak current probabilities, as well as the alternative solutions, if the costs of their construction are not considered, are compared in Table 5.5.

Table 5.5

Recommended Spans Between Protection Devices

Solution	Probability of return stroke peak current I_m								
	90 %			50 %			10 %		
	No. 1	No. 2	No. 3	No. 1	No. 2	No. 3	No. 1	No. 2	No. 3
Protection device type	PAD (150 mm)								
Base solution	3*	2*	3*	3*	2*	3*	3*	2*	3*
Covering XLPE 3.1 mm	3	2	3**	3	2	4**	3	2	4
Covering HDPE 3.9 mm	4	3**	3	3	3**	4	3	3**	4
Intermediate pole S20.I-VT	3	2*	3*	3**	2*	4**	2	2*	4**

* after 20–25 operational years, the renovation of the power line or the installation of protection devices on each pole should be planned.

** after 20–25 operational years, it is recommended to install the protection devices on every 2nd pole.

6. VERIFICATION OF PROPOSED METHODOLOGY

The frequency of the power line flashover ζ depends on various parameters, so it is necessary to look at how each variable parameter affects the value of ζ . All variables are examined for CFO values in the range of 150 kV to 350 kV, which are selected based on the typical values of distribution lines [35]. To examine the effect of each parameter, the remaining variables are constant and have a base value that was also used in Subchapter 5.3. The proposed methodology calculations include the following variables, in brackets the base value is given, if no other value is given for the effect examination:

- 1) height of the power line ($h_l = 10 \text{ m}$);
- 2) width of the power line ($b = 0.8 \text{ m}$);
- 3) days with thunder per year ($T_d = 20 \text{ days with thunder per year}$);
- 4) shielding factor ($S_f = 0.21$, if $h_l = 10 \text{ m}$, $h_k = 10 \text{ m}$, $s_k = 40 \text{ m}$, $I_m = 16.4 \text{ kA}$ and objects are located only on one side of the power line);

- 5) discharge voltage level ($V_{IR} = 180$ kV);
- 6) power line span length ($L = 60$ m);
- 7) pole ground resistance ($R_0 = \infty$);
- 8) ground resistance (ideal ground conductivity or $\rho = 0$ Ω m);
- 9) return stroke velocity ($v = 1.2 \cdot 10^8$ m/s);
- 10) the linear equivalent 0–100% front time ($t_m = 2$ μ s);
- 11) line surge impedance ($Z_s = 480$ Ω);
- 12) median value of return stroke peak value ($I_m = 16,4$ kA).

The impact of the proposed methodology variable calculation parameters on the frequency of the power line flashover ζ is summarized in Table 6.1. The impact value is given as the average variation in percentage of all CFO values by comparing start and end value of the selected range.

Table 6.1

The Impact of the Proposed Methodology Variable Calculation Parameters on ζ

Variable parameter	Range	Variation, %	Comments
S_f	0–0.9	813	Significant impact of S_f on ζ value is observed if $S_f \geq 0.6$. If CFO = 150 kV, then the variation of ζ is 117 %
T_d , days with thunder per year	5–200	99	Significant impact of T_d on ζ value is observed till $T_d = 40$ days with thunder per year
ρ , $\Omega \cdot$ m	0–1500	62	ρ does not affect ζ , if CFO > 250 kV
t_m , μ s	0.5–30	45	Increasing CFO increases t_m impact on ζ
h_l , m	7–13	39	With increasing h_l , with smaller CFO ζ value decreases faster
v , m/s	$0.3 \cdot 10^8 - 2.4 \cdot 10^8$	32	v does not affect ζ , if CFO > 200 kV. If CFO = 150 kV, then the variation of ζ is 89 %
I_m , kA	1–200	31	$I_m > 40$ kA does not significantly affect ζ
L , m	20–140	20	$L > 60$ m does not significantly affect ζ
R_0 , Ω	1–10	8	
V_{IR} , kV	50–200	8	
Z_s , Ω	480–500	1	
b , m	0.4–2.4	1	

Table 6.1 shows that the frequency of the power line flashover ζ is most affected by the shielding factor S_f (Fig. 6.1) and the number of days with thunder per year T_d , but least effected by the width of the power line b and line surge impedance Z_s . Because of the greatest impact on direct lightning strike caused flashover rate, the S_f values for 21 different cases are given in the Annex of the Doctoral Thesis.

Certain parameters affect ζ only at CFO < 200 ÷ 250 kV, which again proves that due to the depreciation of the covered conductor overhead line the reduced power line CFO value can be the determining factor in the increase of lightning caused damages. From the results of the impact of the variable parameters on the frequency of the power line flashover ζ , it can be seen that the power line with a CFO < 175 kV significantly reduces the value of ζ . Comparing ζ

obtained with CFO = 150 kV and CFO = 175 kV, one can see that the difference is approximately 50 %.

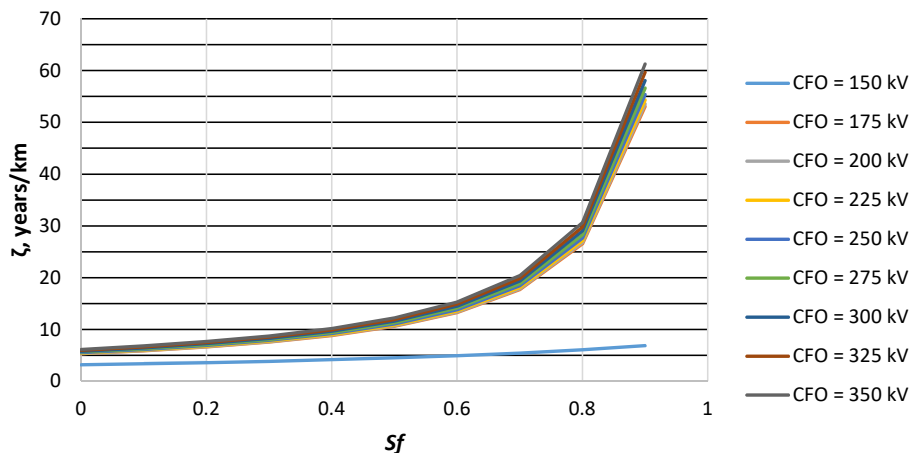

Fig. 6.1. Frequency of the power line flashover depending on the shielding factor.

With IEEE 1410 and SINTEF methodology determined power line flashover rate F , expressed in terms of the frequency of the power line flashover ζ using Expression (5.2) and the proposed ζ limit values in Table 5.1, we obtain the protection device placement frequency, which is summarized in Table 6.2.

Table 6.2

Comparison of Number of Spans Between Protection Devices

Methodology for protection device placement		Section type No. 1	Section type No. 2	Section type No. 3
LEK 015		-	4-5	4-5
SINTEF		-	4	4
IEEE 1410		2	2	3
Proposed methodology	XLPE 2.3 mm covering	3	2	3
	XLPE 3.1 mm covering	3	2	4
	HDPE 3.9 mm covering	3	3	4

The results show that the number of spans obtained with the proposed methodology are in the range between the results of SINTEF and IEEE 1410 methodologies. In the SINTEF methodology, the protection device placement frequency coincides with the frequency according to LEK 015, which provides poorer protection of the covered conductor, than in the proposed methodology, however, using an alternative covered conductor, it is possible to increase the number of spans between protective devices without reducing the protection.

MAIN RESULTS AND CONCLUSIONS

1. The proposed methodology and algorithm for determining the lightning protection device placement frequency, in addition to the lightning caused flashover rate F , which until now has been the only evaluation criterion, takes into account the predicted effect of the depreciation of covered conductor overhead lines on the flashover rate and the analysis of alternatives by choosing different power line components and pole types.
2. The protection device placement frequency is most affected by the power line CFO, as well as the geographic conditions of the power line or the location of the power line and the height and distance from the power line of the nearby objects. From the results obtained, it can be seen that nearby objects by shielding the power line can change the frequency of the power line flashover ζ more than 9 times, and the number of annual days with thunder T_d up to 2 times; therefore, additional attention to the algorithm of the proposed methodology is paid to the parameters which influence the ζ value most significantly.
3. From gathered and analysed lightning discharge statistics in Latvia during the period from 2006 to 2017, the following results were obtained:
 - the average negative polarity lightning discharge in Latvia is 86 % of all discharges that coincide with the values given in the literature;
 - the average median return stroke peak current of negative polarity discharge $I_m = 16.4$ kA, that allows to perform calculations with return stroke peak current value corresponding to the region of Latvia, which is almost 2 times smaller than the median value given in the literature, resulting in more accurate calculations;
 - the number of annual days with thunder T_d in Latvia can range from 4 to 38 days, but the average value varies from 15 to 23 days per year. The average value of T_d in the whole territory of Latvia is 19 days with thunder per year.
4. In EMTP/ATP software a lightning simulation model for medium voltage overhead lines with covered conductors is developed, by which the lightning peak current I_m , which causes the power line flashover, is estimated. With computer simulation model the effect of protection device placement on power line flashover rate is obtained. From the results obtained from the developed model, the protection device mounted on the side of the power supply can also protect the power line from lightning, however, the lightning caused arc is more likely to form on the load side.
5. Within the framework of the Doctoral Thesis, the values of the S_f of nearby objects are developed for 10 %, 50 %, and 90 % return stroke peak current probability, the power line height h_l from 7 to 13 m, and height h_k and distance of 7 different objects from power line s_k in a range from 2.5 to 80 m. As a result, compared to the IEEE 1410 methodology, the S_f values for distribution lines are more precise.
6. The database structure for minimal CFO values for various power line components (insulators, covered conductor and insulating material) has been developed, which can be supplemented to carry out an analysis of alternatives by choosing different power line components.
7. The curves of predicted power line CFO reduction coefficient k_{CFO} have been developed, which take into account various mechanical damage not related to the operation of the power line, the influence of environmental pollution and depreciation of covered conductor covering on the CFO of medium voltage overhead lines with covered conductors.

BIBLIOGRAPHY USED IN SUMMARY

1. Accessories for Medium Voltage Distribution Networks – Ensto Overhead. Ensto Sekko Oy, Finland, 2006, 52 p.
2. Agrawal, A. K., Price, H. J., and Gurbaxani, S. H. *Transient Response of a Multiconductor Transmission Line Excited by a Nonuniform Electromagnetic Field*. IEEE Transactions on Electromagnetic Compatibility, vol. EMC-22, May 1980, pp. 119–129.
3. Aizsargjoslu likums. Stājas spēkā: 11.03.1997. Publicēts: "Latvijas Vēstnesis", 56/57 (771/772), 25.02.1997.
4. Ametani, A. *Lightning surge analysis by EMTP and Numerical Electromagnetic Analysis Method*. 30th International Conference on Lightning Protection, Calgari, Italy, 2010.
5. AS "Sadales tīkls" Tehniskā politika (apstiprināta 09.05.2018).
6. Ausgrid Network Standard 220. *Overhead Design Manual*. February 2011, 261 p.
7. Brown, R. E. *Electric Power Distribution Reliability*. 2nd edition. Boca Raton: CRC Press, 2009, 504 p.
8. Bulinski, A., Bamji, S., Densley, J., Shimizu, N. *Accelerated aging of XLPE cable insulation*. Conference on Electrical Insulation & Dielectric Phenomena, Buck Hill Falls, USA, October 1983, pp. 294–300.
9. Cabral, R. J., Gazzana, D. S., Leborgne, R. C., Bretas, A. S., Dias, G. A. D., Telló, M. *Analysis of Distribution Lines Performance Against Lightning Using ATP-EMTP*. International Symposium on Electromagnetic Compatibility – EMC Europe. Rome, Italy, 2012.
10. CIGRE. *Protection of Medium Voltage and Low Voltage Networks against Lightning Part 2: Lightning protection of Medium Voltage Networks*. CIGRE Technical Report 441, December 2010, 38 p.
11. CIRED/CIGRE Working Group 05. *Protection of MV and LV networks against lightning. Part I. Basic information*. CIRED. 14th International Conference and Exhibition on Electricity Distribution. Part I, 1997.
12. CS type composite silicone insulators for all pollution of the atmosphere levels.
<http://www.aiz.lt/en/production/insulators/composite-silicone-insulators-for-overhead-power-transmission-lines/lk-70-20-iii-lk-70-20-vii>
13. Cummins, K. L., Krider, E. P., Malone, M. D. *The U.S. National Lightning Detection Network™ and Applications of Cloud-to-Ground Lightning Data by Electric Power Utilities*. IEEE Transactions on Electromagnetic Compatibility, Vol. 40, No. 4, November 1998, pp. 465–480.
14. Darveniza, M. *A practical extension of Rusck's formula for maximum lightning induced voltage that accounts for ground resistivity*. IEEE Transactions on Power Delivery, Vol. PWRD 22, No. 1, January 2007, pp. 605–612.
15. EN 62305-1:2011 *Protection against lightning. General principles*, 74 p.
16. Eriksson, A. J. *The Incidence of Lightning Strikes to Power Lines*. IEEE Transactions on Power Delivery, Vol. PWRD-2, No. 2, July 1987, pp. 859–870.
17. Hartono, Z. A., Robiah, I. *The collection surface concept as a reliable method for predicting the lightning strike location*. 25th International Conference on Lightning Protection, September 2000, Rhodes, Greece, pp. 328–333.
18. Hashimoto, Y., Fukui, H., Yano, T., Tsukazaki, M., Sakakiwara, M. *Development of Current Limiting Arcing Horn (MOV type arrester with external gap) for 22kV power distribution line*. 7th Asia-Pacific International Conference on Lightning, Chengdu, China, November 2011.
19. Heidler, F., Cavetic, J. M. *A Class of Analytical Functions to Study the Lightning Effects Associated with the Current Front*. European Transaction on Electrical Power. Vol. 12, No. 2, April 2002, pp. 141–150.
20. Heidler, F., Zischank, W., Flisowski, Z., Bouquegneau, Ch., Mazzetti, C. *Parameters of lightning current given in IEC 62305 - background, experience and outlook*. 29th International Conference on Lightning Protection. Uppsala, Sweden. June 23–26, 2008.
21. Hileman A. R. *Insulation Coordination for Power Systems*. Boca Raton, London, New York: CRC Press, 1999, 772 p.
22. IEEE Modelling and Analysis of System Transients Working Group. *Modelling guidelines for fast front transients*. IEEE Trans. Power Del., Vol. 11, No. 4, January 1996, pp. 493–506.

23. IEEE Standard 1410–2010. *IEEE guide for improving the lightning performance of electric power overhead distribution lines*. January 2011, 63 p.
24. Jankov, V. *Estimation of Maximal Voltage Induced on an Overhead Line Due to the Nearby Lightning*. IEEE transactions on Power Delivery, Vol. 12, No. 1, January 1997, pp. 315–324.
25. Kizhlo, M., Kanbergs, A., Kizhlo, M. *Correlation analysis between grounding resistance and seasonal variations of upper soil resistivity of two-year period in Balozhi, Latvia*. International Symposium on Power Electronics Power Electronics, Electrical Drives, Automation and Motion, Sorrento, Italy, June 2012, pp. 890–893.
26. Kuussaari, M., Mutila, T. *Arc Protection of Covered Conductor Lines in Medium Voltage Networks*. Research report, Fortum Technology, 18 March 1999, 70 p.
27. Lehtonen, M. *Fault rates of different types of medium voltage power lines in different environments*, Proceedings of the 2010 Electric Power Quality and Supply Reliability Conference, Kuressaare, Estonia 2010, pp. 197–202.
28. LEK 015. *Vidsprieguma /6, 10, 20 kV/ gaisvadu elektrolīnijas galvenās tehniskās prasības*. Latvijas enegostandarts. Trešais izdevums, 2016. 42 lpp.
29. LEK 120. *20 kV gaisvadu elektrolīniju koka balsti. Konstruktīvas un materiāli*. Latvijas enegostandarts. Otrās izdevums, 2013. 283 lpp.
30. Lightning Induced Overvoltage code web page – LIOV. *Introduction*. <http://www.liov.ing.unibo.it/introduction.html>
31. LVS EN 50397-1:2007 *Pārklātie maiņstrāvas gaisvadu līniju vadi un to armatūra nominālajam spriegumam no 1 kV līdz 36 kV (ieskaitot). 1. daļa: Pārklātie vadi*, 22 lpp.
32. LVS EN 50397-3:2010 *Pārklātie maiņstrāvas gaisvadu līniju vadi un to armatūra nominālajam spriegumam no 1 kV līdz 36 kV (ieskaitot). 3. daļa: Lietošanas norādījumi*, 20 lpp.
33. Marti, J. R., *Accurate Modelling of Frequency-Dependent Transmission Lines in Electromagnetic Transient Simulations*. IEEE Trans. Power Apparatus and Systems, Vol. 101, 1982, pp. 147–155.
34. Mikropoulos, P. N., Tsovilis, T. E., Pori, A. S. *Evaluation of Lightning Attachment and Coupling Models for the Estimation of the Lightning Performance of Overhead Distribution Lines*. International Conference on Lightning Protection (ICLP), Shanghai, China. October 2014.
35. Nishimura, F., Cicarelli, L. D., Coelho, M., Trager, B., Soares, M. R. *Covered cable comparative testing: HDPE and XLPE evaluation*. 2001 IEEE/PES Transmission and Distribution Conference and Exposition, Atlanta, USA, November 2001.
36. Nowbakht, A., Ahrarinouri, M., Mansourisaba, M. *Presenting a new method to estimate the remaining life of aerial bundled cable network*. 23rd International Conference on Electricity Distribution, Lyon, France, June 2015.
37. Omidiora, M. A. *Modelling and Experimental Investigation of Lightning Arcs and Overvoltages for Medium Voltage Distribution Lines*. Doctoral Dissertation, Helsinki, Aalto University, 2011, 191 p.
38. Panosch, W., Schongrundner, K., Kominek, K. *20 kV overhead lines with covered conductors*. 16th International Conference and Exhibition on Electricity Distribution. Part 1: Contributions. CIRED. (IEE Conf. Publ No. 482), Amsterdam, Netherlands, June 2001.
39. Rusck, S. *Induced Lightning Overvoltages on Power Transmission Lines with Special Reference to the Overvoltage Protection of Low Voltage Networks*. Transactions of the Royal Institute of Technology, Stockholm, No. 120, 1958.
40. Solutions for overhead line networks. Accessories for up to 45 kV, Ensto, 2015, 108 p.
41. Voldhaug, L., Robertson, C. *MV overhead lines using XLPE covered conductors. Scandinavian experience and NORWEB developments*. IEE Colloquium on Review of Options for Overhead Rural Distribution, London, UK, March 1995.
42. Wareing, B. *Wood Pole Overhead Lines*. Power and energy series 48. – London: The institution of engineering and technology, 2005, 336 p.
43. Yokoyama S., Sato T., Shozo S., Hashimoto Y. *Lightning performance of insulated wires on overhead power distribution lines*. 30th International Conference on Lightning Protection, Calgari, Italy, September 2010.
44. Zimackis, V. *Comparison of Commonly Used Mathematical Models for Lightning Return Stroke Current Waveform*. 13th International Conference of Young Scientists on Energy Issues: Proceedings of CYSENI 2016, Lithuania, Kaunas, May 26–27, 2016, pp. 123–130.



Viesturs Zimackis, born in 1989, in Riga, is a third-generation electrical engineer. In 2013, he graduated from Riga Technical University with distinction receiving the Master degree of Engineering Sciences in Power and Electrical Engineering.

Since 2010, he has worked in the field of electrical engineering, in the beginning as an assistant electrician, later as electrical network and installation designer and head of design department. Currently he is working in the field of sales of electrical devices. Along with his main work responsibilities he is actively involved in training activities on lightning and surge protection for contractors and designers.

His main research field is lightning, lightning protection zone estimation, lightning and surge protection.