



**COST ACTION TU1406**  
**QUALITY SPECIFICATIONS FOR ROADWAY BRIDGES,**  
**STANDARDIZATION AT A EUROPEAN LEVEL**

**eBook for the 5th Workshop Meeting**

**Riga, 23-24 November 2017**

**Editors : Ainars Paeglitis, Jose Matos, Irina Stipanovic, Rade Hajdin, Amir Kedar, Vikram Pakrashi**

**Publisher : Riga Technical University, Faculty of Civil Engineering, Latvia**

**ISBN : 978-9934-22-067-8**



# Opening Note from the Chair

The COST Action TU1406 Workshop in Riga was very successful, covering several topics related to quality control framework (WG3), case studies (WG4) and guidelines / standardization activities (WG5). Although very cold outside, the Workshop was very “hot” in terms of the quality of the discussion and the main outcomes which were achieved. There were four Keynote presentations, covering the bridge management activities in two International Partner Countries, respectively, South Africa and Russia, focusing the other two such problematic in the Baltics, namely, in Latvia and Estonia. Other interesting presentations covered the multi objective decision making on bridge management, the topic of scour and how may we address it in quality control, the maintenance scheduling for bridge stocks, the case study applications of quality control frameworks, and the liaison standardization works with CEN, ISO and JCSS.



Prof. Jose Matos  
Chair COST Action  
TU 1406

# Opening Note from the Chair

The large number of participants in the Action, as well as the excellent attendance in this Workshop, reinforces the interest around Europe in the objectives of the Action. As pointed out several times during the presentations and discussions, it is of paramount importance the involvement of academics as well as professionals working in the field of roadway bridge assessment and management. The meeting in Riga has been a key point to continue the collaborative work between both parts, playing the Industry Advisory Board an important role on that. In summary, looking to the success of this Workshop, we may be confident on the achievement of the required standardization of the quality specifications for highway bridges across Europe.



Prof. Jose Matos  
Chair COST Action TU  
1406

# Acknowledgement

The editors would like to thankfully acknowledge the contribution of those who supported the execution of this event:

**Riga Technical University, Faculty of Civil Engineering**

and especially to:

**Juris Smirnovs**, *Dean of Faculty of Civil Engineering of Riga Technical University*

**Ilze Paeglite**, *Faculty of Civil Engineering of Riga Technical University*

**Janis Smirnovs**, *Faculty of Civil Engineering of Riga Technical University*

**Eleni Chatzi**, *Technical Secretariat of COST Action TU1406*

**Sérgio Fernandes**, *Technical Support of COST Action TU1406*

**Lara Leite**, *Administrative Secretariat of COST Action TU1406*

# Table of Contents

## Opening Session

José Matos, Chairman of COST TU1406

Juris Smirnovs, Dean of Faculty of Civil Engineering, Riga Technical University, Latvia

## Session 1

**Keynote speaker:** Roberts Auzins, Latvian State Roads, Latvia: *Achievements of bridge management in Latvia*

**Keynote speaker:** Pilate Moyo, University of Cape Town, South Africa: *Experiences with management and structural performance assessment of highway bridges in South Africa*

Zaharah Bukhsh, University of Twente, The Netherlands: *Robustness of the MAUT model applied to bridge maintenance planning*

Nikola Tanasić, University of Belgrade, Serbia: *Assessment of reliability of bridges exposed to local scour*

# Table of Contents

## Session 2

Mariano Angelo Zanini, University of Padova, Italy: *A cost-based quality control plan for a sustainable bridge maintenance scheduling*

Dismosthenis Kifokeris, Aristotle University of Thessaloniki, Greece: *Bridge quality appraisal methodology: application in the Strimonas bridge case study*

Ignacio Piñero, Fundación TECNALIA, Spain: *Deusto bridge. Study and diagnosis for rehabilitation*

Khurram Mumtaz, Bauhaus-University Weimar, Germany: *Benchmark study frame bridge Glattfelden – an intermediate report*

# Table of Contents

## Session 3

**Keynote speaker:** Sander Sein, Estonian Road Administration, Estonia: *Challenges of bridge management in Estonia*

**Keynote speaker:** Anton Syrkov, Transmost, Russia: *Russian bridge management systems - state of the art and further risk-based development*

Naida Ademovic, University of Sarajevo, Bosnia and Herzegovina: *Carbonization and service life protection of a historical reinforced concrete bridge*

Viet Ha Nguyen, University of Luxembourg, Luxembourg: *Bridge monitoring with harmonic excitation and principal component analysis*

# Table of Contents

## Session 4

Odysseas Manoliades, Democritus University of Thrace, Greece: *Inspection processes of Sustainable small bridges: a case study*

Michael Faber, Allborg University, Denmark: *On the Potentials for Synergy Between COST Action TU1406 and the JCSS*

Antonio Burgueño, FCC Construcción, Spain: *Sustainability assessment of civil engineering works*



# Joint WG3, WG4 and WG5 meeting

Poul Linneberg	Frame bridge case study example
Panagiotis Panetsos	Strimonas bridge case study example
João Amado	Arch bridge case study example
Pavel Ryjacek	Case study- road concrete arch bridge Nerestce
Nikola Tanasic	Scour example
Sander Sein	Glatfelter SBB Interfering Frame bridge
Vikram Pakrashi	<i>Presentation of WG5 progress and future plans to date</i>

## Workshop Contributions



# ACHIEVEMENTS OF BRIDGE MANAGEMENT IN LATVIA

**COST ACTION TU 1406**  
**WORKSHOP IN RIGA, SUSTAINABLE BRIDGE MANAGEMENT**  
**(23-24.11.2017)**

SJSC "Latvian State roads"  
Bridge division  
Bridge engineer - Roberts Auziņš

# Key points of presentation

---

1. Introduction;
2. Statistics;
3. Bridge management in Latvia
  - General;
  - Bridge management system – Latbrutus;
  - Load model - LM3.



# Introduction

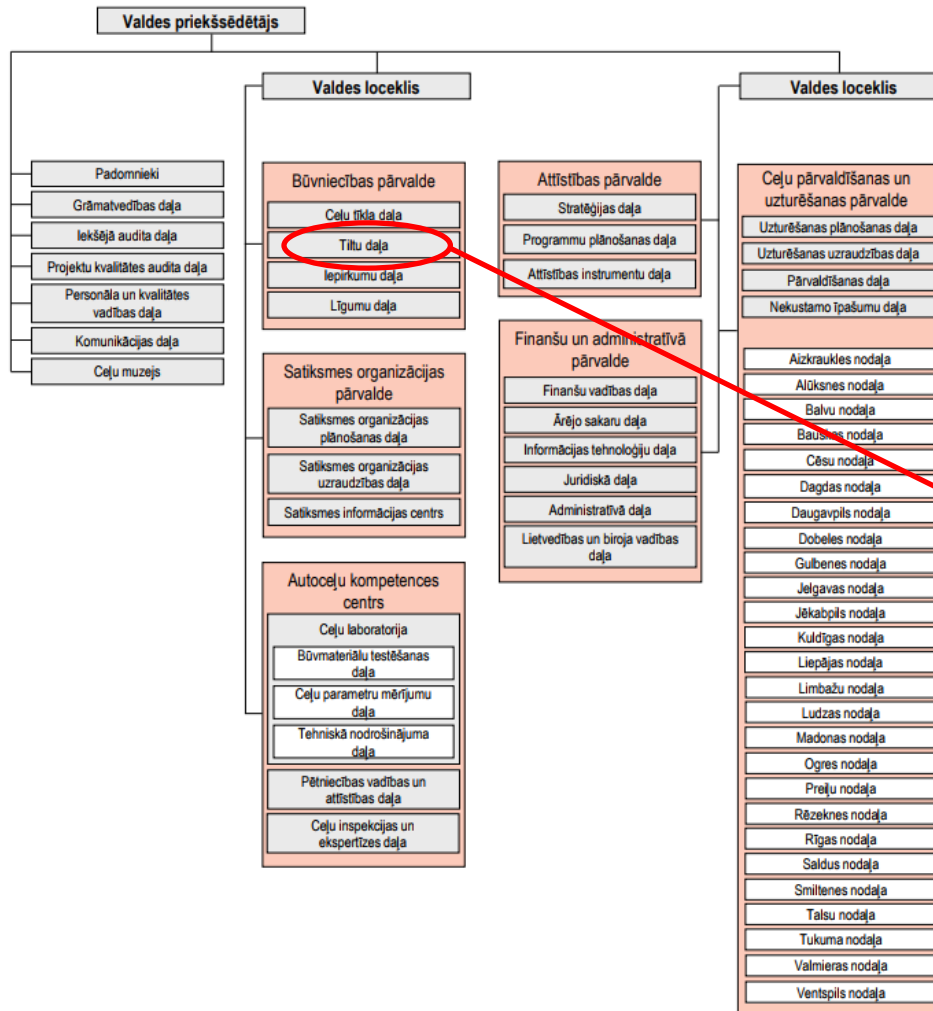

## Bridge division: Headquarters (Riga):

1. Head of division;
2. Two engineers;
3. Database analyst.

## Regions:

In each of our 4 regions one engineer.

# Statistics

---

1. We (LSR) are managing **971 bridges** (including 14 pedestrian bridges) and **882 big culverts** ( $d > 2\text{m}$ );  
(there are no included municipality bridges/culverts, aprox. same amount);
2. Bridge distribution to road classes:
  - Main roads (A) – **172 or 18%** of bridges
  - Regional roads (P) – **353 or 37%** of bridges
  - Local roads (V) – **434 or 45%** of bridges
3. Bridge materials:
  - Reinforced concrete – 94%
  - Steel – 4%
  - Masonry – 1,5%
  - Wood – 0,5%

# Statistics

## Length of bridges:

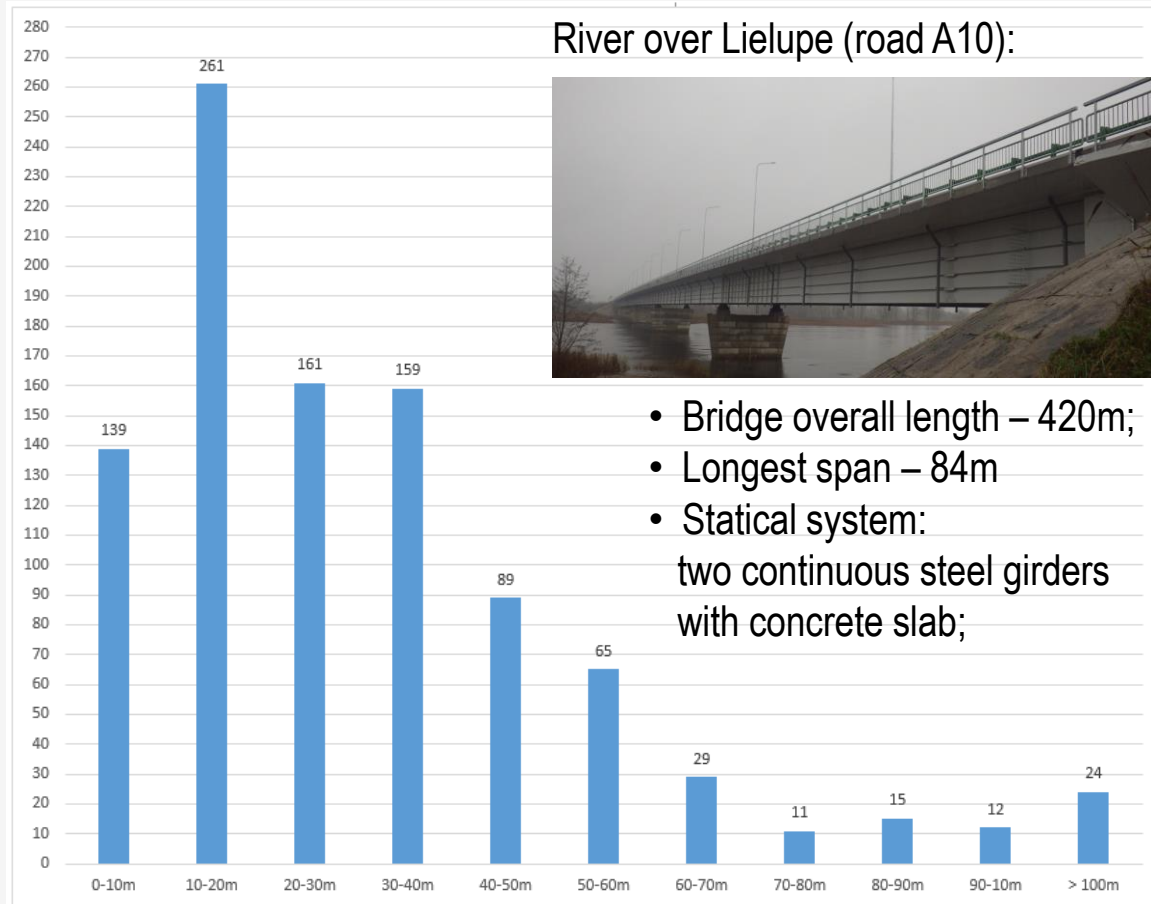

# Statistics

Age of bridges:

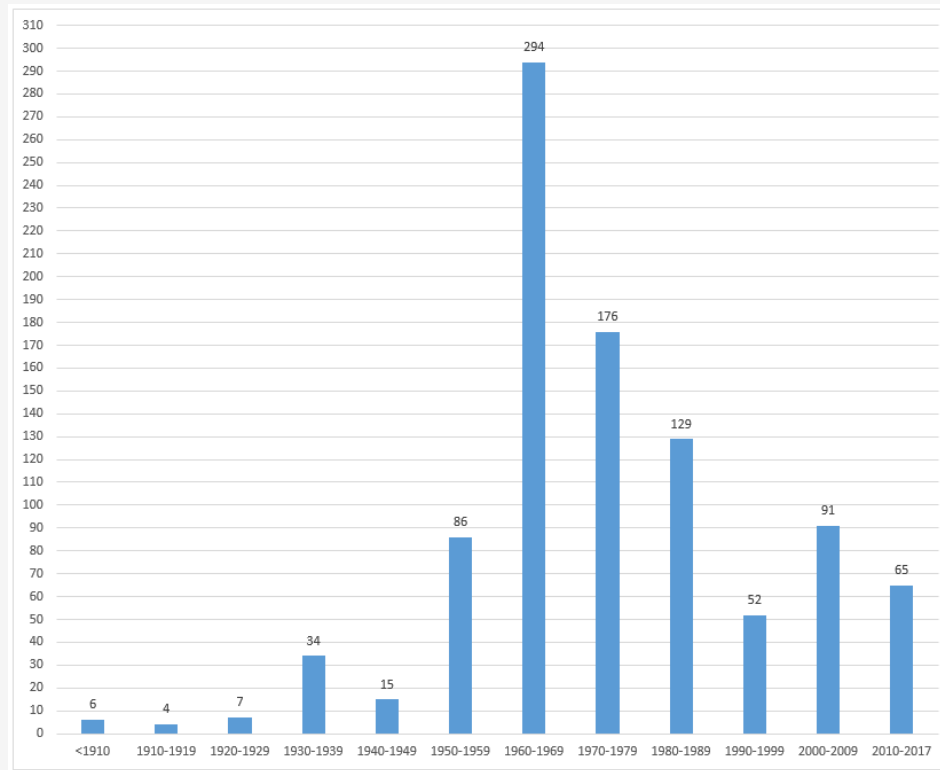

individual  
projects  
(8%)

Soviet time projects  
(76%)

According EC  
(16%)

# Statistics

---

Financing\* in million EUR to bridge renovation and reconstruction:

\*(not included road projects financed by EU)

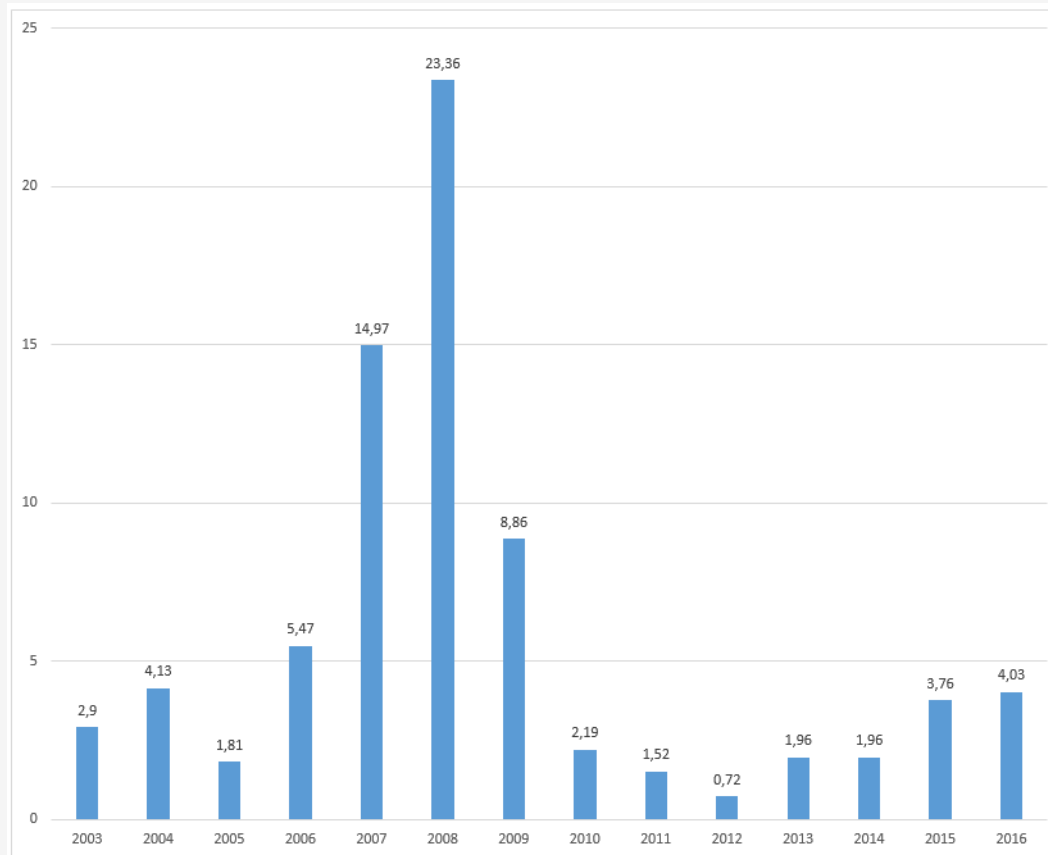



# Statistics

Bridge condition (medium-term planning):

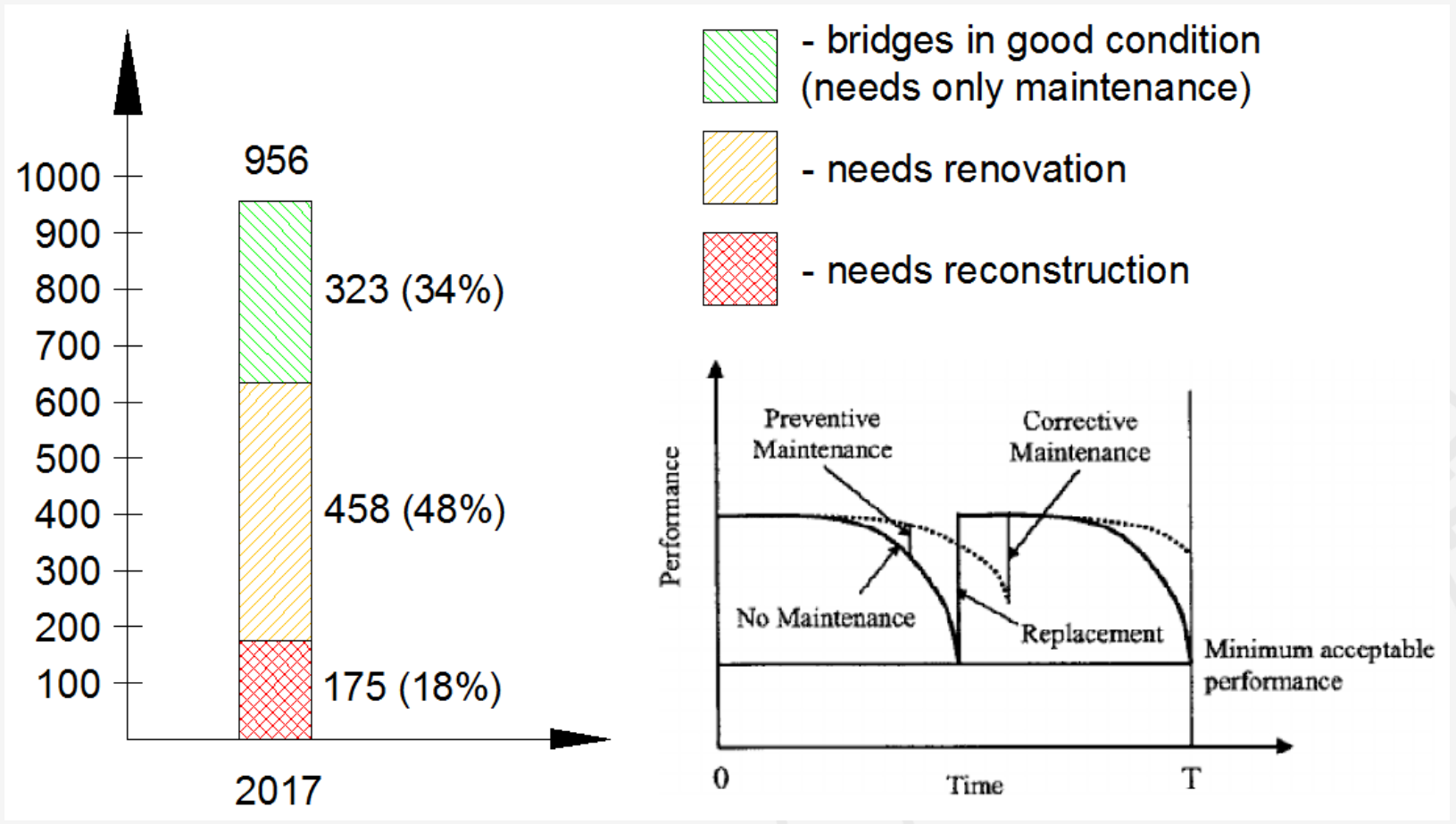

# Bridge management in Latvia

---

General scheme of bridge management in Latvia:

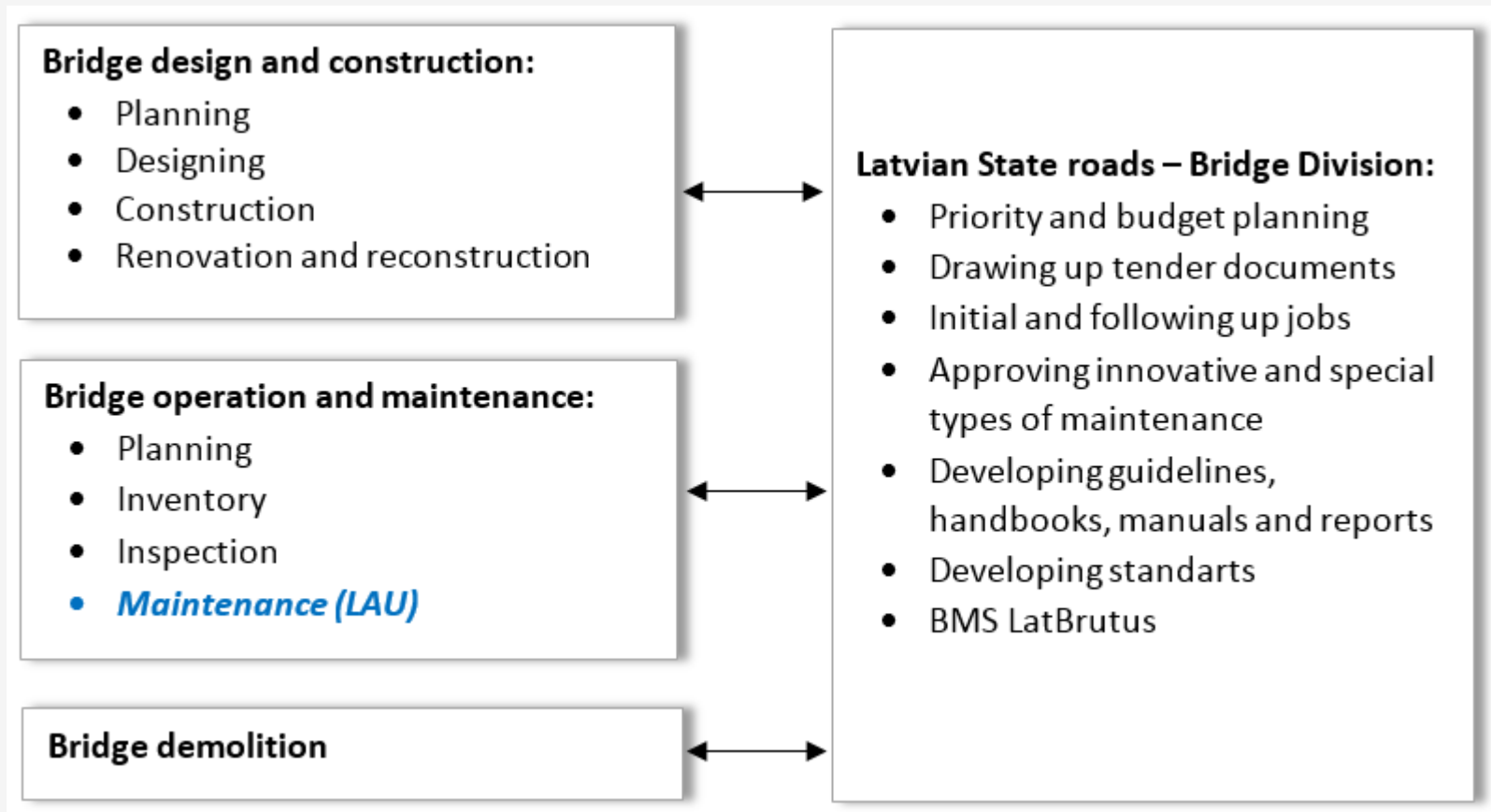

# Bridge management in Latvia

---

Handbooks:

Projektēšanas un būvniecības vadlīnijas  
**TILTU DROŠĪBAS BARJERAS**  
2017



Projektēšanas un būvniecības vadlīnijas  
**TILTU HIDROIZOLĀCIJA UN**  
**SEGUMS 2017**



Handbooks can be found: <http://lvceli.lv/uncategorized/rokasgramatas/>

# Bridge management in Latvia

---

Bridge management system – LatBrutus:

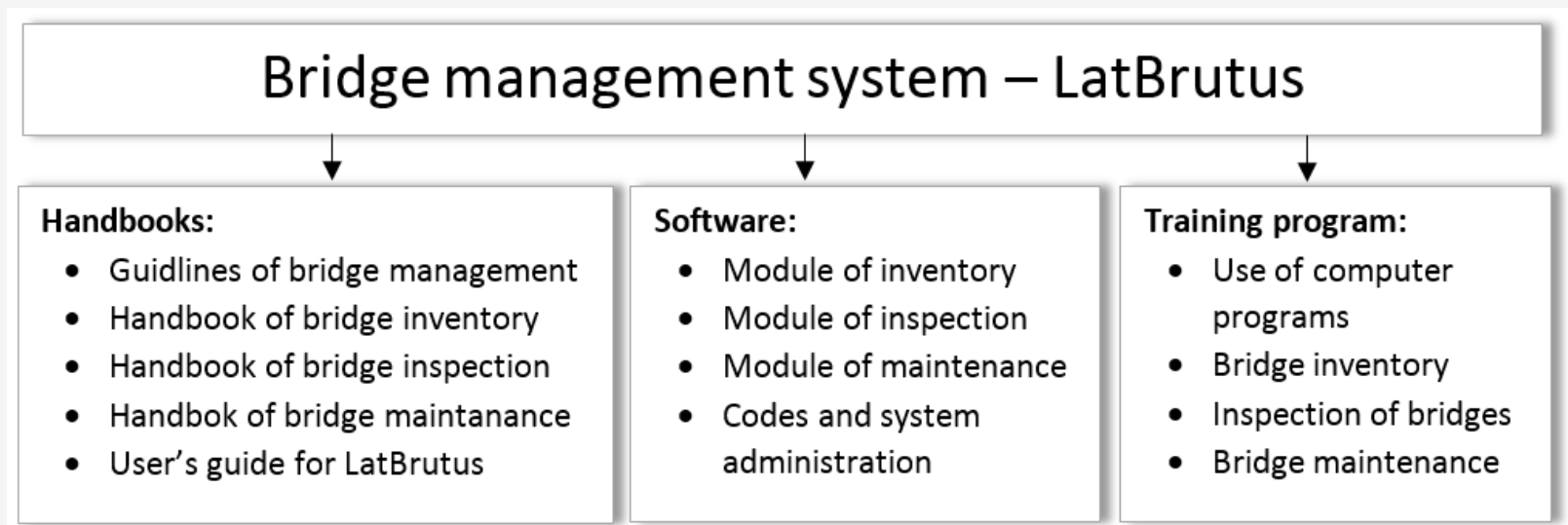

Timeline of LatBrutus:

- Developed from 1997-2002 in cooperation with Norwegian state roads;
- 2002 -2017 in use with no changes.

# Bridge management in Latvia

Scheme of LatBrutus structure:

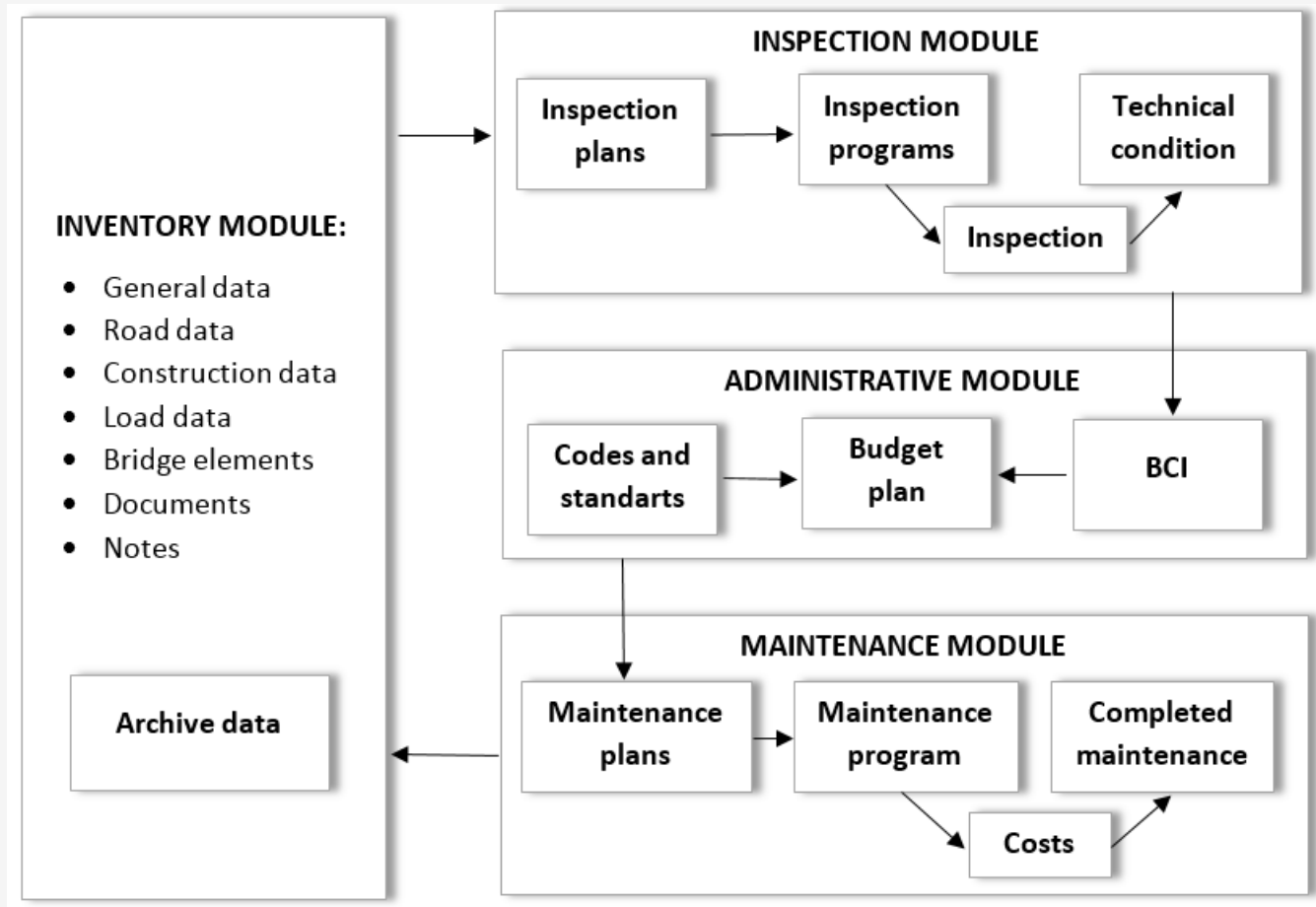

# Bridge management in Latvia

LatBrutus – Inventory module (General data):

The screenshot displays the 'Tiltu datu kartiņa' (Bridge Data Card) window in the LatBrutus software. The interface is divided into several sections, with red callout boxes highlighting specific areas:

- General info:** A table at the top containing bridge details: Rājons (Rūjienas novads), Nr. (0220), Nosaukums (Sedas tilts), Atrašanās vieta (V/P017:28,823), Statuss Tips (ET, Siju tilts), Materiāls (Saliekams - stie), Garums (34,16), and Būves (1960).
- Administrative info:** A section titled 'Administrēšana' with fields for 'Kategorija' (AT - Autoceļu tilts), 'Īpašnieks' (LSM - Latvijas Satiksmes Ministrija), 'Rajons' (9R - Rūjienas novads), and 'Atbildīgais par uzt.' (9.N - LVC Valmieras nodaļa).
- Construction info:** A section titled 'Būvniecība' with fields for 'Projektētājs' (Latdoraautoprojekt 1959), 'Ģenerāluzņēmējs' (Valmieras 9.CBR), 'Uzraugs' (nav zināms), and 'Būvēts' (1960).
- Inspection date and personal:** A section titled 'Pastiprināšanas / Rekonstrukcijas' with a table of inspection records. The first record shows 'Tilta klāja pastiprināšana' performed in 2012 by 'perj.pr.Rīgas tilti būv. SIA Tilti' for 113,508 LS. Below this, a section for 'Inventarizācijas datu kvalitātes kontrole' includes 'Savākšanas datums' (2013-6-10) and 'Savāca' (J.Naudžuns).

Tips	Uzņēmējs nosaukums	Gads	Cena	Valūta
1	Tilta klāja pastiprināšana	2012	113 508	LS

Inventarizācijas datu kvalitātes kontrole	Savākšanas datums	Savāca	Pirma reģ. datums	Pēdējās modif. dat.	Pārbaudīja
	2013-6-10	J.Naudžuns	1999-09-30	2013-08-15	

# Bridge management in Latvia

LatBrutus – Inventory module (Construction data):

Tiltu datu kartiņa

Rajons: Rucavas novads Nr.: 0293 Nosaukums: Līgupes tilts Atrašanās vieta: V/A11:41,826 Statuss: ET Tips: Siju tilts Materiāls: Saliekams - stie Materiāls: Saliekams - stie Garums: 11,36 Būves: 1963

Vispārējās Ceļa dati **Konstruktīcijas dati** Sodzes dati Elementi Dokumenti Piezīmes

**construction type**

Konstruktīcijas tips

Pamat	Konstruktīcijas tips	Materiāla kods	Statiskā shēma	Asis (no - līdz)	Ievietot	Izdzēst
<input checked="" type="radio"/>	31 Siju tilts	13 Saliekams - stiegrots	1 Vienkārši balstīta sistēma	1 2	<input type="button" value="Ievietot"/>	<input type="button" value="Izdzēst"/>
<input type="radio"/>						

**span info**

Laiduma Asis

Asis	Laiduma garums (m)	Ievietot pēdējā	Izdzēst pēdējā	Izdzēst visu
1 Liepāja	11,06	<input type="button" value="Ievietot pēdējā"/>	<input type="button" value="Izdzēst pēdējā"/>	<input type="button" value="Izdzēst visu"/>
2 Lietuvas rob				

Caurtekas  Normals tilts

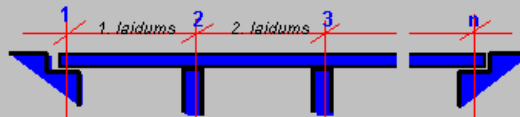

**geometrical data**

Projektētā slotze

Kopgarums:	Kopējais platums:	Kopējais laukums:	Laidums nr.:	Parametru koriģēšana
11,36 m	11,40 m	129,50 m <sup>2</sup>	1	
Garākais laidums: 11,06 m	Brauktuves platums: 9,85 m	Brauktuves laukums: 112 m <sup>2</sup>	Sīpums: ,0 Grad	
Labās ietves platums: ,75 m	Kreisās ietves platums: ,75 m	Ietvju laukums: 17 m <sup>2</sup>		

# Bridge management in Latvia

LatBrutus – Inventory module (Bridge elements):

substructure

superstructure

separate elements

structural material info

Tiltu datu kartiņa

Rajons Nr. Nosaukums Atrašanās vieta Statuss Tips Materiāls Garums Būves

Oļaines novads 0770 Viadukts pār Jaunolaines ceļu V/A05:22,100 ET Siju tilts Saliekams - stie 60,00 1980

Vispārējās Ceļa dati Konstrukcijas dati Slodzes dati **Elementi** Dokumenti Piezīmes

Elementi

Virsbūve  Apakšbūve  Cits  Viss

Kods	Apraksts	Detalizēto elementu tips	Elementu apraksts	Elementu skaits		
32	Sija	2	T-sija	20	1	4
34	Klājs	2	Iepriekš izliets (saliekams)	1	1	4
61	Balstīkla	6	Elastīgā balstīkla	20	1	1
62	Šuve	3	Lietā slēgta šuve	1	1	1
63	Sega uz tilta klāja	3	Bitumena ar pilnu hidroizolāciju	1	1	4
64	Drenāža	1	Drenāža no klāja	2	1	2
65	Barjera	3	Stiepu margas	2	1	4
65	Barjera	1	Sardzes barjeras	2	1	4

Materiāls

1  Dzelzsbetons

Virsmas apstrāde

1  Neapstrādāts

Aizsardzība

1  Nav aizsargāta

Materiāls apraksts

Virsmas apstrāde apraksts

Aizsardzība apraksts

Ievietot

Izdzēst



# Bridge management in Latvia

LatBrutus – Inventory module (Documents):

- Project documentation
- archive data
- special inspections
- other documents

Photos / drawings

Tiltu datu kartiņa

Rajons Nr. Nosaukums Atrašanās vieta Statuss Tips Materiāls Garums Būves

Rūjienas novads 0220 Sedas tilts V/P017:28,823 ET Siju tilts Saliekams - stie 34,16 1960

Vispārējās Ceļa dati Konstrukcijas dati Slodzes dati Elementi **Dokumenti** Piezīmes

Dokumenti

Ieraksta tips	Arhīva adrese	Arhīva norāde	Piezīmes
9 Cita tipa dokumenti	Lad 9.nod		proj.dok.Latdorauprojekt 1959
8 Projekta tehniskā dokument.	LVC 9.nod	Proj.Sifrs M-9-2	Arhiv.Nr.M-22 rekonst proj.dok.Latdoraupr

Ievietot izdzēst

Fotogrāfijas Rasējums

1	2	Attēla Paraksts	Formāts	Izmērs(Kb)	Datums	Sīkattēls	Apskatīt
<input type="radio"/>	<input type="radio"/>	Laidums	GIF	703	2011-05-28		<input type="checkbox"/>
<input type="radio"/>	<input type="radio"/>	Sānskats	GIF	778	2013-06-02		
<input type="radio"/>	<input type="radio"/>	Sānskats	GIF	768	2011-05-28		
<input type="radio"/>	<input type="radio"/>	Daļēji sabrucis ietves apmales a	GIF	733	2005-09-19		
<input type="radio"/>	<input type="radio"/>	ietves bloki un margs	GIF	756	2011-05-28		
<input type="radio"/>	<input type="radio"/>	Virsskats	GIF	820	2011-05-28		

Ievietot izdzēst

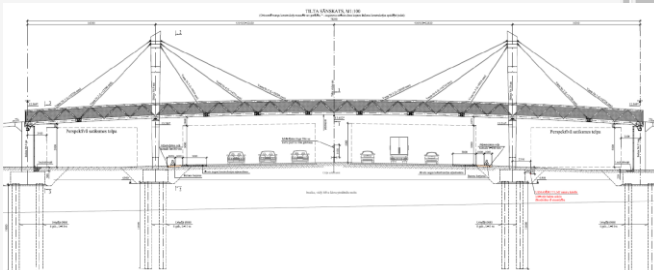

# Bridge management in Latvia

## LatBrutus – Inspection module:

### BCI -Bridge condition index:

(could be from 0-9,99)

$$BCI = \sum (DI_1 \cdot F_1 + DI_2 \cdot F_2 + \dots + DI_n \cdot F_n)$$

DI – Damage index

$$DI = F_{DC} \cdot F_{type}$$

$F_{DC}$  – factor for combined code Degree and consequence of damage (table)

$F_{type}$  – factor for code type of damage (table)

$F_{1,2,\dots,n}$  – factor for each DI

Table for  $F_{DC}$  values

Degree of damage	Consequence of damage			
	C	T	M	A
1	0,0799	0,0412	0,0239	0,0033
2	0,2008	0,1022	0,0651	0,0066
3	0,3903	0,1876	0,1261	0,0083
4	0,9270	0,3068	0,2115	0,0333

Table for  $F_{type}$  values

Npk	Kods	Apraksts (damage description)	Koef. ( $F_{type}$ )
1	101	Grunts/uzbēruma sēšanās	3,00
2	102	Upes gultnes aizsprostojumi	2,50
3	103	Upes gultnes erozija/izskalojumi	4,00
4	104	Neatbilstoša notīrīšana/ novākšana	2,00
5	105	Aizsērējums	1,50
6	106	Nepietiekama caurteces kapacitāte	2,00
7	107	Upes gultnes maiņa	2,50
8	109	Citi upes gultnes bojājumi	1,00
...	...	...	...

The screenshot shows the 'Tilta inspekcija' (Bridge Inspection) software interface. The main window displays a table of inspection results with columns for 'Inspekc. tips', 'Inspekc. datums', 'Inspektors', 'BCI', and 'Piezīmes par inspekciju'. A red box highlights the BCI value of 1.05 for a 'Galvenā inspekcija' on 10.06.2013 by 'Kr.Gode'. Below this, a table of 'Bojāti elementi' (Damaged Elements) is shown with columns for 'Elementi', 'Ass (no-līdz)', 'Bojājuma tips', 'Bojājuma cēlonis', and 'C T M A BI Piezīmes'. A red box highlights the 'C' (Consequence) column for the 'Uzbērums' element, which has a value of 4. A legend explains the consequences: C - damage affect the load carrying capacity, T - damage affect the traffic safety, M - damage can affect maintenance costs, E - damage can influence the environment and aesthetics. Another red box highlights the 'BI' (Degree of Damage) column, which has a value of 0.26 for the 'Uzbērums' element. A legend explains the degree of damage scale: 1 - Minimal damage/defect – actions are not required; 2 - Average damage/defect – actions are required in time of 4- 10 years; 3 - Serious damages/defects – actions are required in time of 1 – 3 years; 4 - Critical damages/defects – urgent actions are required in terms till 1/2 year.

### The consequences of damage indicated:

- C - damage affect the load carrying capacity
- T - damage affect the traffic safety
- M - damage can affect maintenance costs
- E - damage can influence the environment and aesthetics

### The degree of damage shall be evaluated in such numerical scale:

- 1 - Minimal damage/defect – actions are not required;
- 2 - Average damage/defect – actions are required in time of 4- 10 years
- 3 - Serious damages/defects – actions are required in time of 1 – 3 years
- 4 - Critical damages/defects – urgent actions are required in terms till 1/2 year.

# Bridge management in Latvia

LatBrutus – data from inspections:

**Inspekcijas shēma**  
Galvenā inspekcija

Tilta Nr. 908 Konstrukcijas tips : 59 Metāla kopnes tilts Laidumu skaits :1		Atrašanās: a/c V304 Drustu stacija - Zosēni, 3,30km Garums: 32,60m			Pirmā ass 1		Pēdējā ass 2			
Izpildes inspekcijas Izpildīts (gads): 2017 Insp. tips: Galvenā inspekcija		Plānotas inspekcijas Plānots (gads): Insp.tips: Galvenā inspekcija								
Elementi Materiāls	Asis (no-līdz)	Bojājuma tips	Bojātā stāvokļi			Bojājuma cēlonis	Darbs Nr.	Mērvienība		Summa, EUR
			C	T	A			Cena Eur	Kvant.	
11 Upes gultne 1-2 Smiltis		-				-	-	-	-	
12 Uzbērums 1-1 Smiltis, velēnojums		814 Plaša veģetācija		2	2	44 Neatbilstoša uzturēšana	S 8.22	10.00	20m <sup>2</sup>	200.00-
12 Uzbērums 2-2 Smiltis, velēnojums		814 Plaša veģetācija		2	2	44 Neatbilstoša uzturēšana	S 8.22	10.00	20m <sup>2</sup>	200.00-
21 Gala balsts 1-1 Dzelzsbetons		216 Betona elementa neatbilstoša tīrība		2	1	44 Neatbilstoša uzturēšana	S 8.22	20.00	3m <sup>2</sup>	60.00-
21 Gala balsts 2-2 Dzelzsbetons		216 Betona elementa neatbilstoša tīrība		2	1	44 Neatbilstoša uzturēšana	S 8.22	20.00	3m <sup>2</sup>	60.00-
26 Gala siena 1-1 Dzelzsbetons		-				-	-	-	-	
26 Gala siena 2-2 Dzelzsbetons		202 Betona elementa pārvietošanās 204 Plaisas betona elementā		β	2	62 Grunts spiediens 62 Grunts spiediens	S 8.428	600.00	2.5m <sup>3</sup>	1500.00-
34 Klājs 1-2 Plānas klānes klājs		306 Tērauda elementa virsmas pārklājuma bojājums		2	2	44 Neatbilstoša uzturēšana	S 8.57	35.00	135m <sup>2</sup>	4725.00-
37 Kopnes konstr. 1-2 SARM		306 Tērauda elementa virsmas pārklājuma bojājums 314 Tērauda elementa daļas trūkums		3	2	44 Neatbilstoša uzturēšana	S 8.42	35.00	160m <sup>2</sup>	5600.00-
61 Balstīklas 1-1 Gumijas		-			1	44 Neatbilstoša uzturēšana	S 8.51	1.00	38gb.	38.00-
61 Balstīklas 2-2 Gumijas		-				-	-	-	-	

908 –Gaujas tilts; V304; km 3,30.

# Bridge management in Latvia

---

LatBrutus – Some examples and clasification of defects:

(Damage code / Degree of damage - consequence / Damage couse)

214 / 3C / 53



214 / 4C / 53



209 / 3C / 59



712 / 3M / 13 or

38



202 / 4T / 44



306 / 2A / 38



# Bridge management in Latvia

## BRIDGE LOADINGS:

Road traffic regulations in Latvia:

Without special permission:

- 40t for ordinary truck;
- 44t for ISO container truck;
- 52t for timber lorries\*;

Problem:

A lot of bridges are built in different times according different normatives and design loads. No normative base to in-use bridges.

Aim:

To supplement normative regulations with procedure how to evaluate load carrying capacity of in-use bridges.

Scheme of 52t timber lorries:

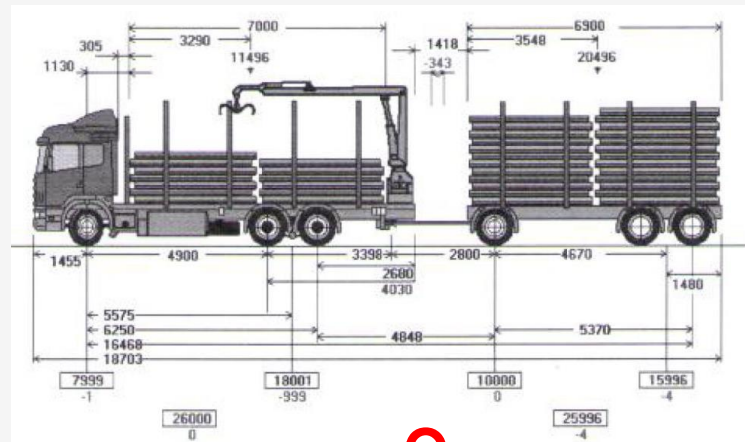

Real life:



# Bridge management in Latvia

## BRIDGE LOADINGS – Load model LM3:

In bridge **renovation projects** we are recalculating bridge bearing capacity to our self created **load model LM3** which represents everyday traffic loads.

Load model LM3 is based on:

- Standardized Soviet time projects;
- MK-279 «*Ceļu satiksmes noteikumi*»;
- MK-343 «*Noteikumi par leilgabarīta un smagsvara pārvadājumiem*»;
- WIM data;
- Police data.

LM3 model summary can be found:

<http://lvceli.lv/uncategorized/rokasgramatas/>

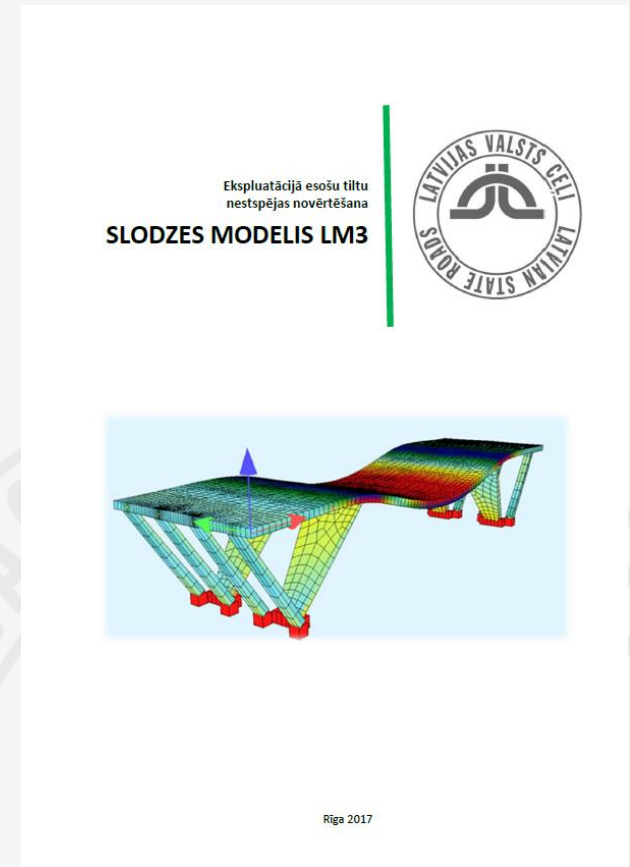

# Bridge management in Latvia

## BRIDGE LOADINGS – LM3 block scheme:

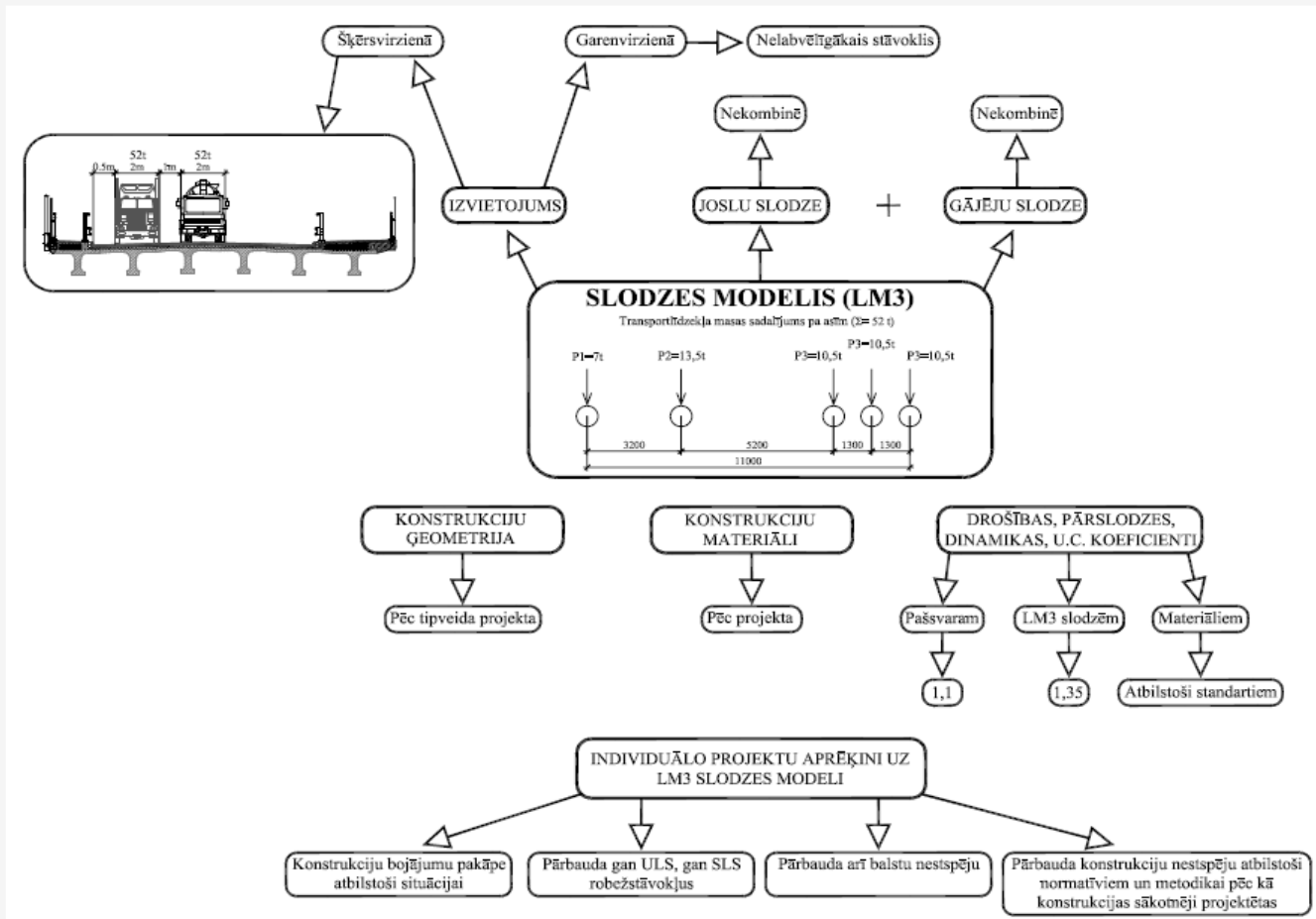

# Thank you for your attention!



Roberts Auziņš  
roberts.auzins@lvceli.lv





# MANAGEMENT AND STRUCTURAL PERFORMANCE ASSESSMENT OF BRIDGES IN SOUTH AFRICA

**Pilate Moyo** - University of Cape Town, South Africa

**Paul Nordengen** - Council for Scientific and Industrial Research, South Africa



**UNIVERSITY OF CAPE TOWN**  
IYUNIVESITHI YASEKAPA • UNIVERSITEIT VAN KAAPSTAD

**ENGINEERING & THE BUILT ENVIRONMENT**



**TRANSNET**

freight rail

# TYPICAL BRIDGES IN SOUTH AFRICA



# TYPICAL BRIDGES IN SOUTH AFRICA



# TYPICAL BRIDGES IN SOUTH AFRICA



# TYPICAL BRIDGES IN SOUTH AFRICA



# TYPICAL BRIDGES IN SOUTH AFRICA



# TYPICAL BRIDGES IN SOUTH AFRICA



# TYPICAL BRIDGES IN SOUTH AFRICA





# TYPICAL BRIDGES IN SOUTH AFRICA



# BRIDGE MANAGEMENT IN SA

- Road & Rail operators are responsible for BMS
- Owners select and implement own systems
- Main bridge owners are:
  - National Road Agency
  - Transnet Freight Rail
  - Provincial Governments
  - Cities

# BRIDGE MANAGEMENT IN SA

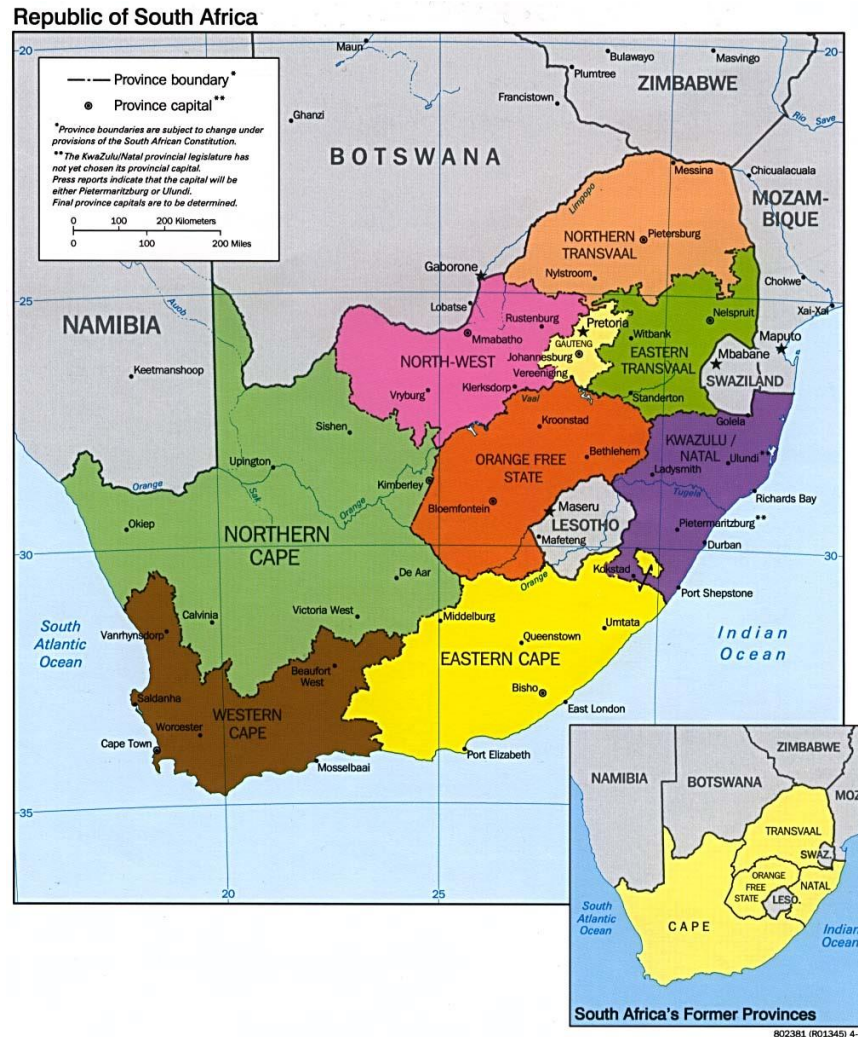

# WHY BMS IS IMPORTANT IN SA

- South Africa has a large stock of old bridges
  - Majority built in the period 1950-1980
  - Some more than 100years old
- Need to grow infrastructure base to support economy
- Cheaper to rehabilitate/retrofit existing structures
- Thus management and maintenance strategies required
- Allocation of funds on the basis of credible information
- For Government Depts, now a requirement through ‘Immovable Asset Management Act’ and ‘Public Finance Management Act’

# STRUMAN BMS

- Used by most bridge owners in South Africa and Southern Africa
- Developed by the Council for Scientific and Industrial Research Built Environment, SA
- Network level inspections
  - Aim to identify bridges in most need of maintenance interventions
  - Condition index and priority index
  - Also provides indication of budget
- Project level inspections
  - Detailed inspections to design & implement maintenance interventions
  - Often involve NDT and testing

# STRUMAN BMS

- Early detection of defects, through prompt diagnosis of symptoms, allows defects to be treated quickly, thus allowing meaningful savings to be made on maintenance expenditure.
- All visible defects on structure are rated and quantified
- Defects are rated to place them in order of priority
- Rating should accurately represent the effect of the defect on the **structural integrity** of the structure
- It should also represent the effect of the defect on **safety of the user** and **the serviceability of structure**
- Survey should be systematic to ensure all defects are recorded

# STRUMAN BMS

- 21 basic bridge elements are inspected and evaluated. These are:
  1. Approach embankment
  2. Guardrails
  3. Waterway
  4. Embankment protection
  5. Abutment foundations
  6. Abutments
  7. Wing & retaining walls
  8. Surfacing/ballast
  9. Deck drainage
  10. Kerbs/sidewalks
  11. Parapets & handrails
  12. Pier protection work
  13. Pier foundations
  14. Piers & Pylons
  15. Bearings
  16. Support drainage
  17. Expansion joints
  18. Longitudinal members  
(decks & arches)
  19. Transverse members
  20. Deck slabs & arches
  21. Miscellaneous

# DER rating system

D – DEGREE of defect

How bad or severe is the defect

E – EXTENT of defect

How common is the defect on the inspection item being inspected

R – RELEVANCY of defect

Considers the consequences of defects with regard the safety of the user and the structural integrity of the structure

U – URGENCY to carry out the remedial work

Provides a way of applying time limits on the repair requirements



# DER rating system

Category	X	U	0	1	2	3	4
Degree/ Severity (D)	N/A	Unable To Inspect	No defect	Minor	Fair	Poor	Severe
Extent (E)				Local	> Local	< General	General
Relevancy (R)				Minimum	Moderate	Major	Critical
Urgency (U)	Make Safe (MS)	Record (R)	Monitor	Routine	< 10 yrs	< 5 yrs	ASAP

# STRUMAN BMS

- The bridge inspector is not required to condition rate each and every element
- Only elements with defects are rated i.t.o DER and then only the most significant defect with the highest relevancy
- Time on site is reduced as one is only looking for defects and not trying to estimate a condition rating for the structure

# INSPECTOR REQUIREMENTS

- Good understanding of structural behaviour
- Experienced (minimum of 5 years design experience)
- Trained in the use of the DER rating system
- Pay attention to detail

# INSPECTOR REQUIREMENTS



# INSPECTOR REQUIREMENTS

## Assessment of Bridge Inspectors: Calibration Inspections

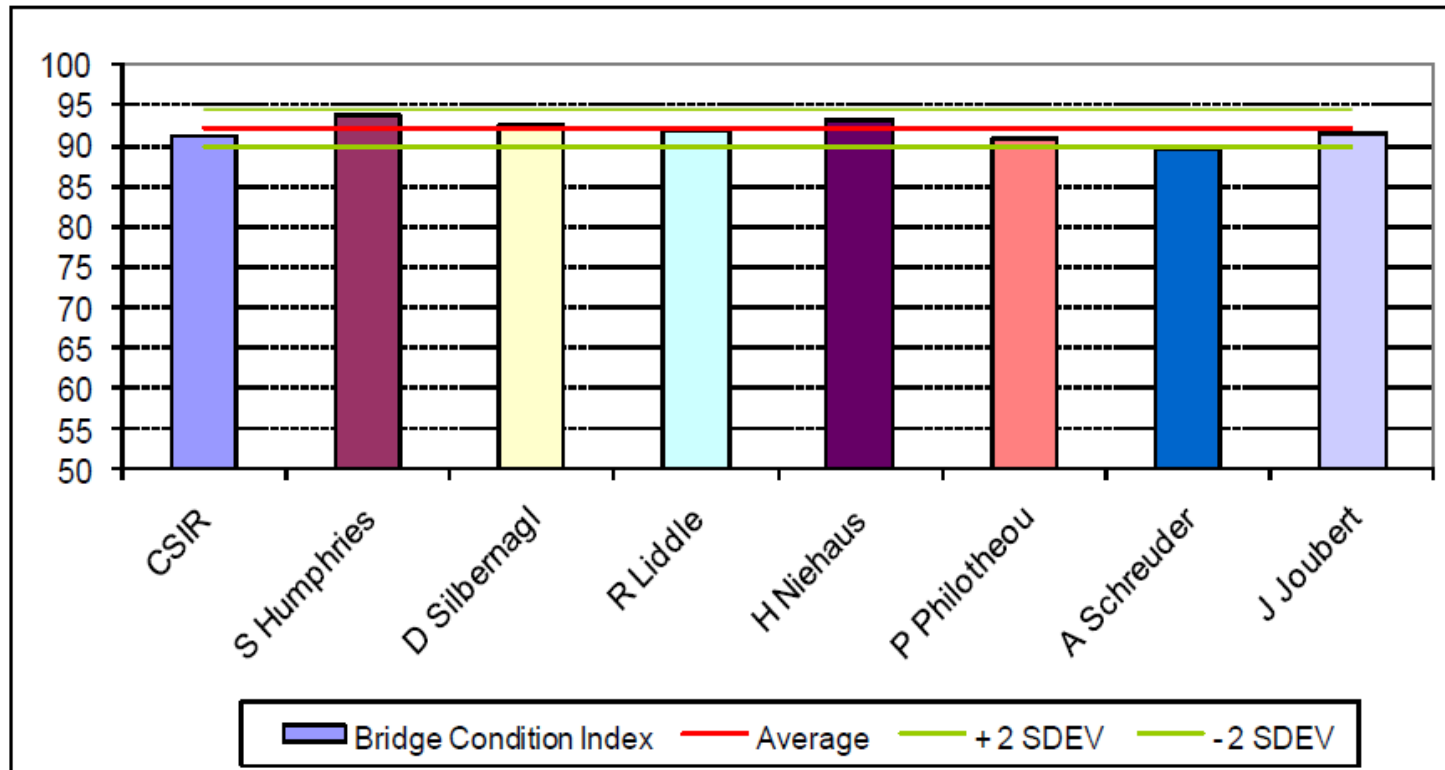

# STRUMAN BMS

DER METHODOLOGY

DOCUMENTATION

SOFTWARE

**BRIDGE MANAGEMENT SYSTEM**

Inspection Type	Frequency	File	Code	Number/Date	SR#
Visual	12 Months	Visual	001	001/01/01	001
Structural	24 Months	Structural	002	002/01/01	002

Support	Inspection	Frequency	File	Code	Number/Date	SR#
1	1	12 Months	Visual	001	001/01/01	001
2	2	24 Months	Structural	002	002/01/01	002

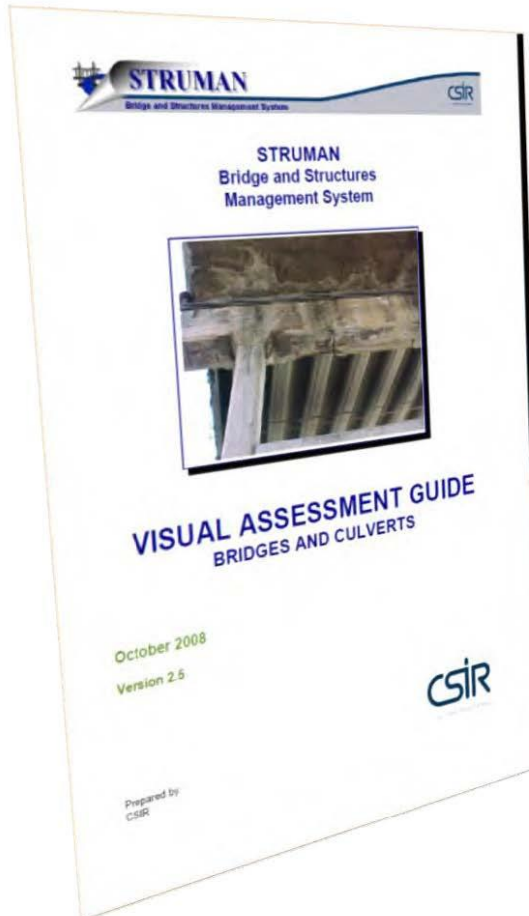

# STRUMAN BMS

## Prioritisation

- Required for maintenance, repair and rehabilitation activities on structures in a network
- Structures with the greatest need for repair should be given the highest priority
- Two major categories are used to prioritise structures
  - Structural adequacy
  - Functional index
- Structural adequacy is a function of D,E&R ratings
- Functional index is a function of the following
  - Type of structure, Class of structure, Detour length, etc...
- Secondary to optimisation process

# STRUMAN BMS

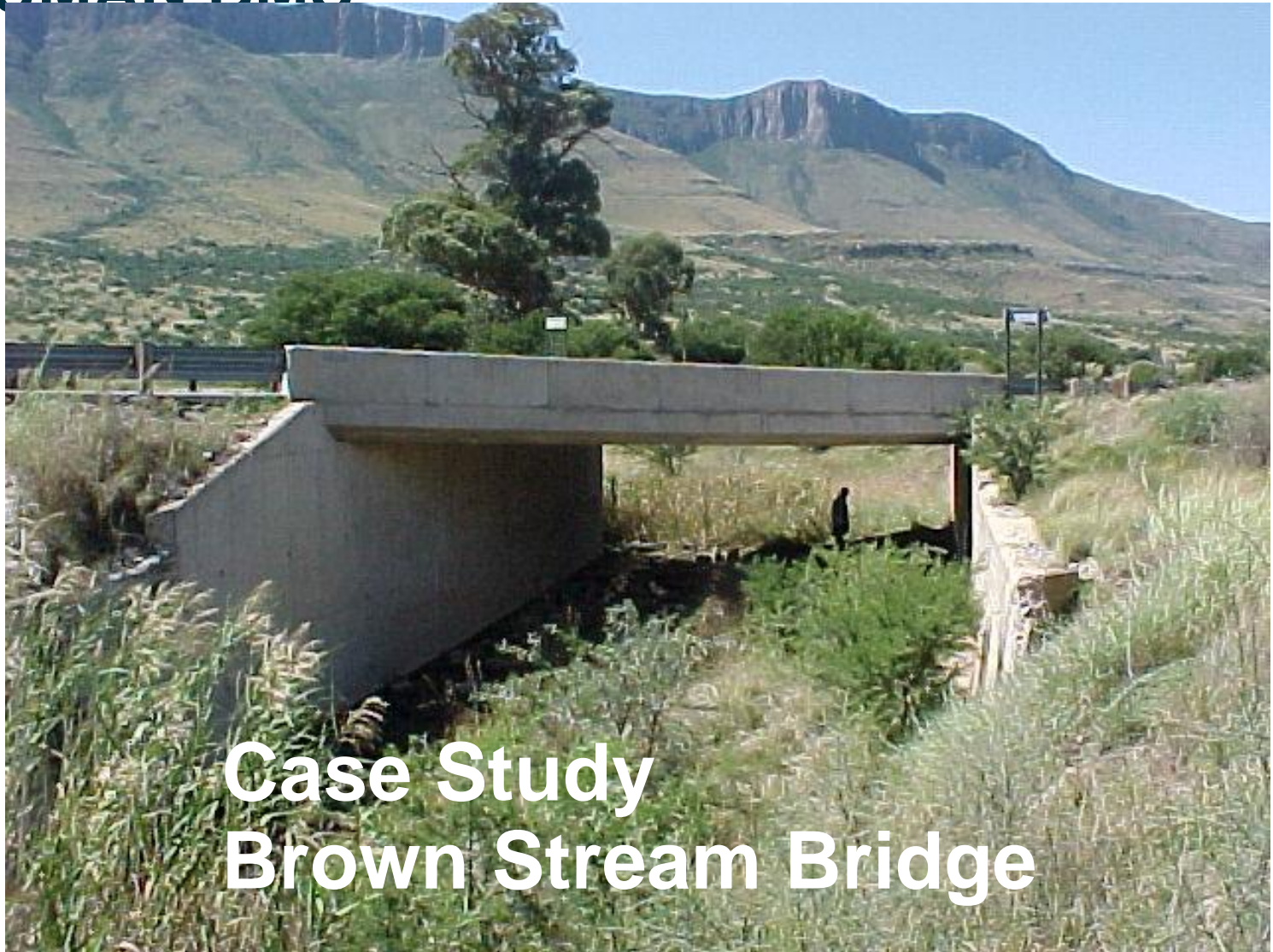

## Case Study Brown Stream Bridge



# STRUMAN BMS



# Rating of defect (crack)

## Notice the following:

- Thickness of slab 700mm
- Sag in deck edge – can even be seen on elevation
- On site one could notice 3 mm joints in barrier had closed up



**D = 3 (3)**

**E = 2 (2)**

**R = 4 (3)**



# Repairs done

OPI was No 52 out of 2 000

- A design check was done & deck found to have only 30% of LL Capacity
- Strengthening not feasible due to steel stressed beyond yield
- Could hear crunching of concrete when vehicles crossed
- Deck was demolished and replaced
- During demolition when deck had been demolished half way it collapsed under own weight!!!
- Parapet formed an edge beam that supported the deck and live loads



# PROJECT LEVEL ASSESSMENT CASE STUDY

- riveted steel railway bridge
- Required assessment for future loading
- Emphasis on fatigue assessment



# PROJECT - example

- Vibration based system identification



- Typical roving accelerometer set-up

# PROJECT LEVEL -example

View: 3D View  
 [Complex Shape]  
 BLK: scaledX  
 Freq: 2 (Hz)

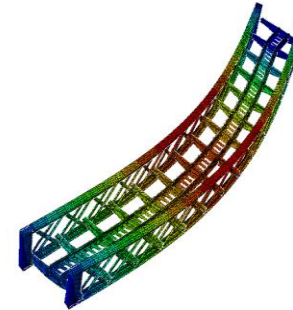
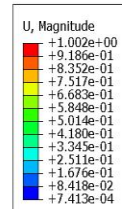
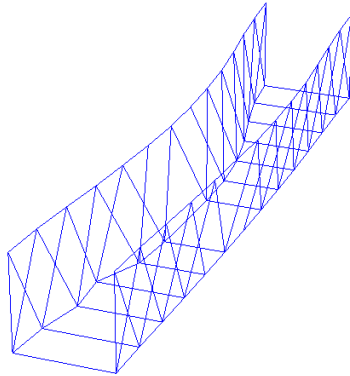

ODB: SPUpdated.odb Abaqus/Standard 6.14-1 Sun Aug 09 21:30:17 South Africa Standard Time 2015  
 Step: Step-2  
 Mode 1: Value = 162.73 Freq = 2.0303 (cycles/time)  
 Primary Var: U, Magnitude  
 Deformed Var: U Deformation Scale Factor: +3.440e+00

## Natural frequencies

Mode	Theoretical frequency (Hz)	Measured frequency (Hz)
First lateral bending mode	2.03	2.00
First lateral sway mode	2.56	2.50
First vertical bending mode	5.44	5.72

# Model Validation

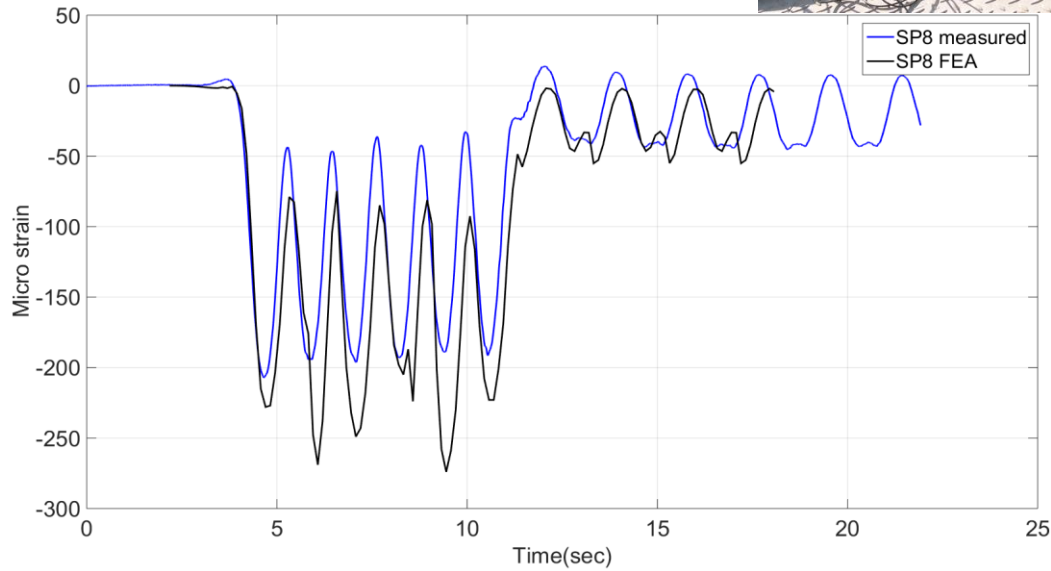
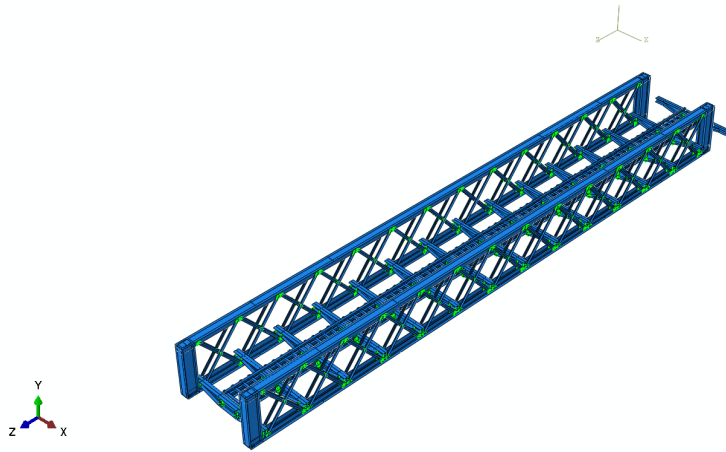

# PROJECT - example

- Rainflow method used to count fatigue cycles
- BS5400 Part 10 was used for fatigue analysis
- Stress range based on stresses obtained from calibrated model
- Moving train load -speed 80km/h



# PROJECT - example

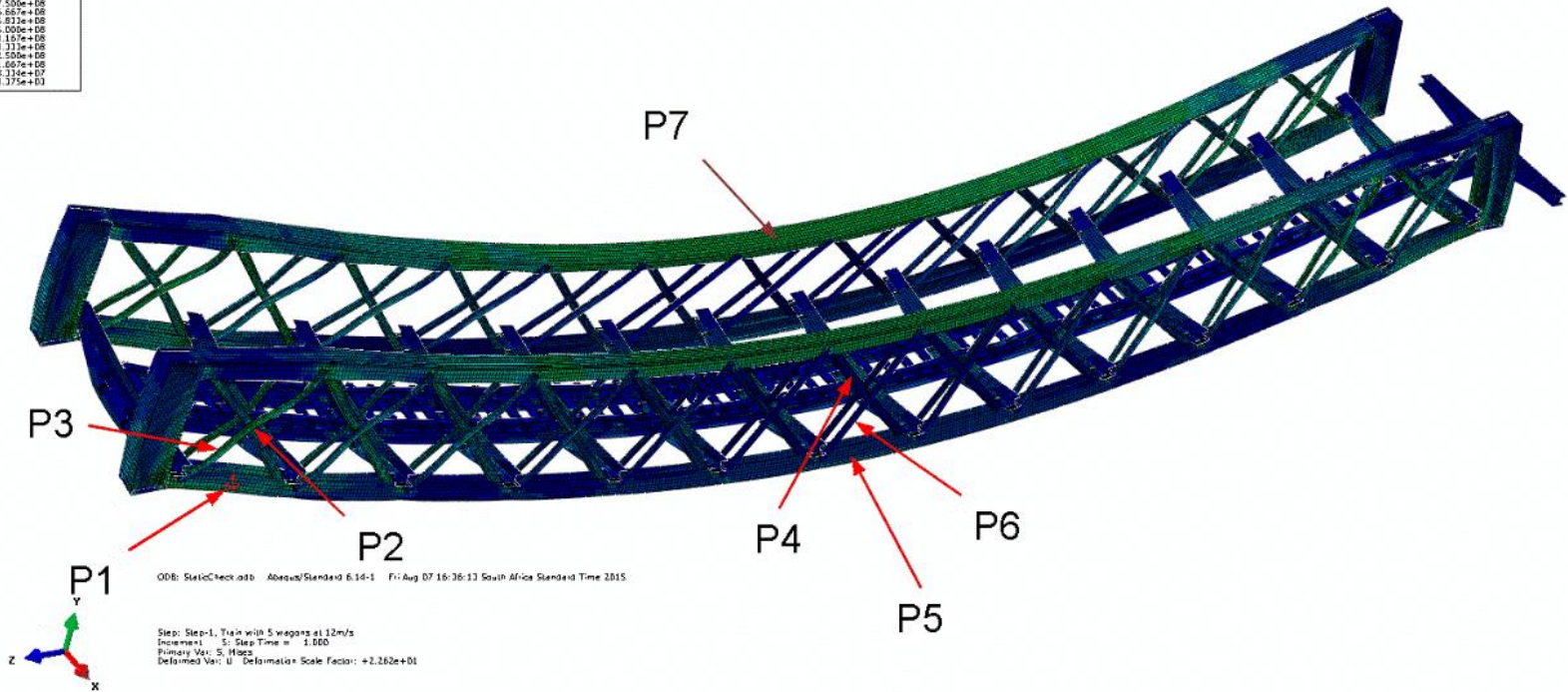
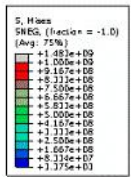

# PROJECT -Example

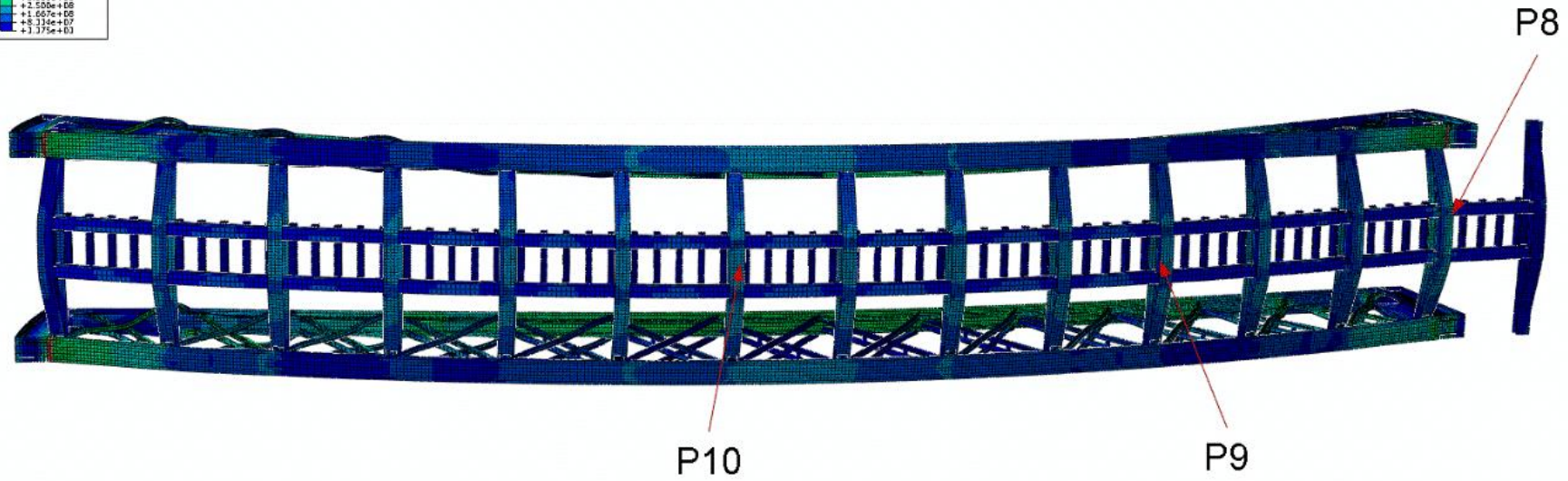
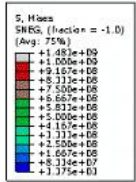

ODB: StaticCheck.odb Abaqus/Standard 6.14-1 Fri Aug 07 16:36:13 South Africa Standard Time 2015



Step: Step-1, Tied with 5 wagons at 12m/s  
 Increment: 5, Step Time = 1.000  
 Primary Var: S, H Max  
 Deformed Var: U, Deformation Scale Factor: +2.262e+01

# PROJECT

- rail bearer and cross-girders found to be susceptible to fatigue
- Further fracture mechanics based assessments under way

# CONCLUSION

By having a Bridge Management System:

- Structures are maintained at acceptable levels of service
- Defects are identified timeously and repaired economically
- Prioritisation (optimisation) of work (expenditure)
  - Funds channelled to more important defects
  - Expenditure reduced on less important defects
- Improved control of expenditure by management
- Accessibility of information
  - Decision making easier (Impact of decisions)
  - Detail of output depends on user



# ROBUSTNESS OF THE MAUT MODEL APPLIED TO BRIDGE MAINTENANCE PLANNING

**Zaharah Allah Bukhsh<sup>1</sup>, Irina Stipanovic<sup>1,2</sup>, Sandra Skaric<sup>2</sup>, Giel Klanker<sup>3</sup>**

*<sup>1</sup>University of Twente, Faculty of Engineering Technology, Enschede, The Netherlands*

*<sup>2</sup>Infra Plan Consulting Ltd., Zagreb, Croatia,*

*<sup>3</sup>Rijkswaterstaat Ministry of Infrastructure and the Environment, Utrecht, Netherlands*

# Introduction

- A multi-objective decision support model is suggested for maintenance planning based on multi-attribute utility theory
- The model considers multiple performance aspects quantified by performance indicators
- A decision maker can state his preferences for each performance indicators by assigning weights
- The purpose of this study was to determine the robustness of the proposed model by conducting sensitivity analysis

# Overview of the process

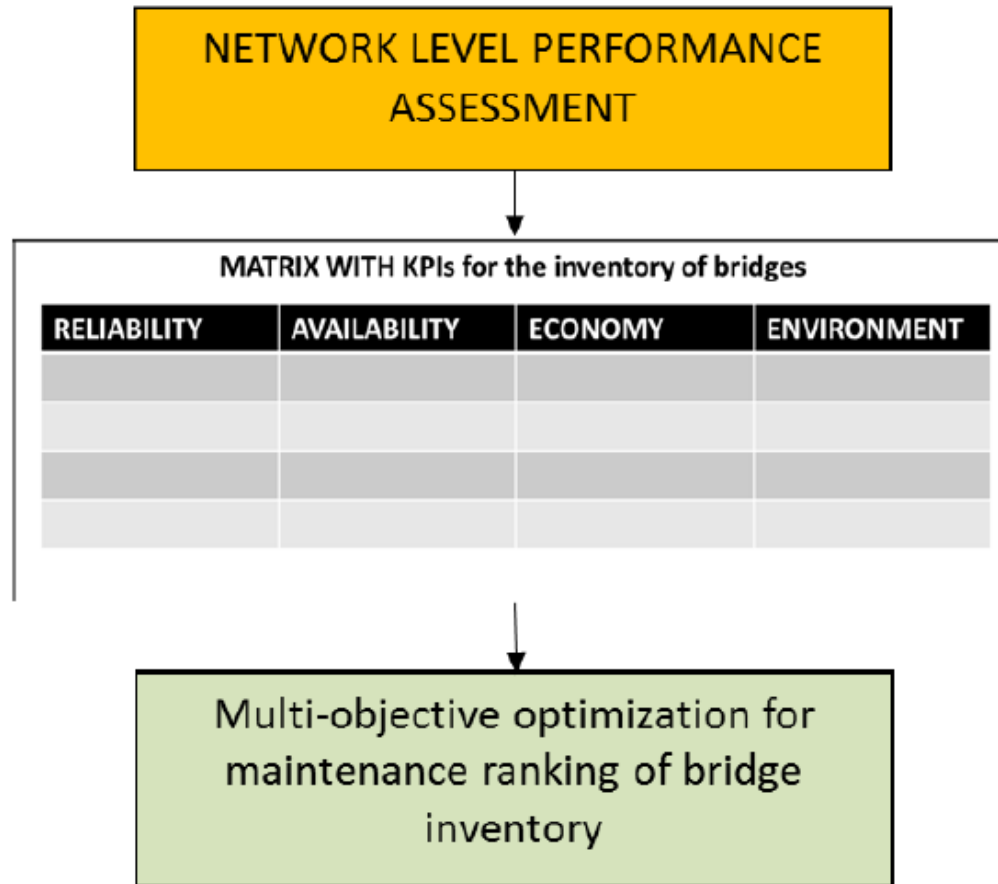

# Multi-attribute utility theory

- Utility theory provides a measure to consider stakeholders' preferences
- The main advantage is its consideration of uncertainty
- Utility function reduce the quantitative values of different attributes into 0-1, thus enabling comparison
- The mathematical formulation of MAUT is

$$U(x) = k_1 U(x_1) + k_2 U(x_2) + \dots + k_n U(x_n)$$

$$U_{i(x_i)} = A - B * e^{\left(\frac{RT}{x_i}\right)}$$



# Case Study

- The objective is to rank the bridges alternatives considering four performance aspects
  - Reliability (KPI – bridge condition index)
  - Economy (KPI – maintenance cost only)
  - Environment ( KPI – environmental cost)
  - Availability (KPI – User delay cost)

Where the maintenance cost , environmental cost and user delay cost can be minimized while reliability is maximized

- These objectives are conflicting in nature e.g. to minimize delay cost, the owner cost will increase
- Therefore, a tradeoff among objectives need to be made

# Case Study

- Data of 22 bridges from Rijkswaterstaat was used for this purpose
- The owner cost, BCI, environmental and user delay cost for each bridge was calculated
- The single utility function of each attribute is computed by following formula

$$U_{i(x_i)} = A - B * e^{\left(\frac{RT}{x_i}\right)}$$

where A & B are scaling constant

RT is risk tolerance

The detail calculation procedure of attributes and MAUT application can be found in (Allah Bukhsh et. al., 2017)

# Single utility function – Owner cost

- Expected value
- Certainty Equivalent

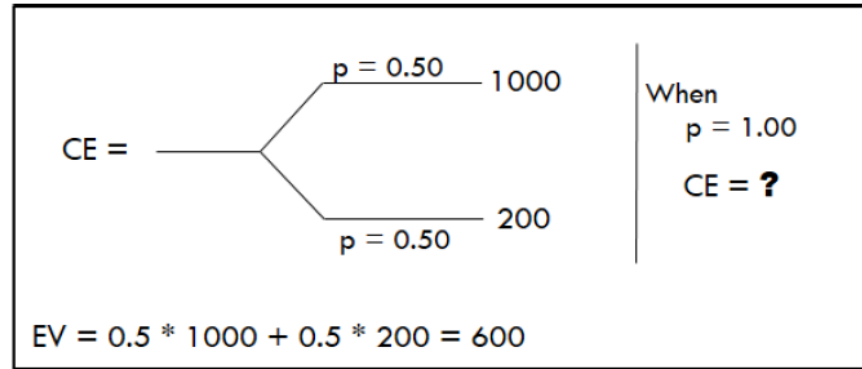

Risk Attitude = {

- Risk Neutral, if  $EV = CE$  (*Linear shaped*)
- Risk Avoiding, if  $EV > CE$  (*Concave shaped*)
- Risk Taking, if  $EV < CE$  (*Convex shaped*)

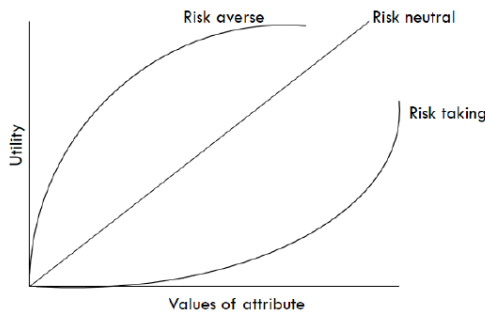

# Single utility function – Owner cost

- Expected value
- Certainty Equivalent

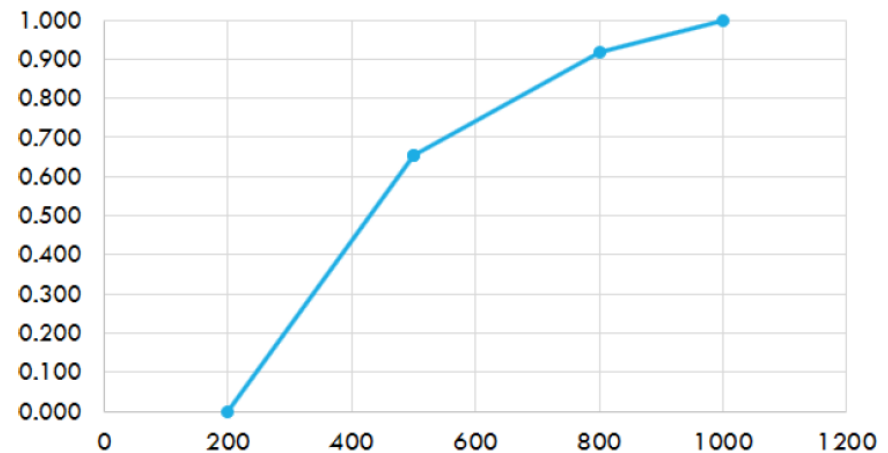
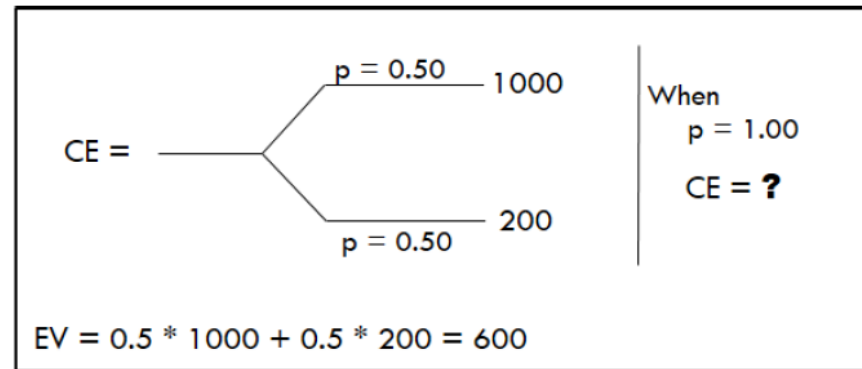

CE = 400

# Multi-objective optimization

Bridges with assigned ranks –Risk neutral, equal weights

Name.	Aggre. Condition	Maintenance cost	Environmental Cost	User delay cost	U(Agg. Cond)	U(MC)	U(En. Cost)	U(Uc)	Additive	Rank
Bridge 1	3.1050	144.8192	0.8888	39.7001	0.9444	0.9812	0.8506	0.9330	0.944	5
Bridge 2	1.8877	126.4059	0.2050	27.5019	0.2884	0.9623	0.3406	0.8172	0.293	21
Bridge 3	2.2086	115.6748	0.5749	25.5664	0.5810	0.9437	0.6984	0.7877	0.583	14
Bridge 4	3.1263	161.8502	1.1132	13.6378	0.9486	0.9902	0.9137	0.4804	0.947	4
Bridge 5	2.0000	68.1613	0.5303	12.4031	0.4064	0.6709	0.6679	0.4309	0.408	18
Bridge 6	2.1236	149.2116	0.2289	47.8949	0.5161	0.9841	0.3726	0.9699	0.519	16
Bridge 7	3.3559	196.7584	0.7081	57.7852	0.9866	0.9976	0.7748	0.9934	0.986	2
Bridge 8	2.4152	88.5989	1.2491	13.1125	0.7097	0.8459	0.9401	0.4599	0.710	8
Bridge 9	2.2194	45.8212	1.2567	35.8932	0.5888	0.2467	0.9414	0.9069	0.590	13
Bridge 10	2.3390	115.9342	0.4336	30.8020	0.6666	0.9443	0.5917	0.8590	0.668	11
Bridge 11	2.4152	39.4222	0.2321	12.6881	0.7097	0.0451	0.3767	0.4427	0.706	9
Bridge 12	3.4595	138.5160	1.8516	12.1170	1.0000	0.9761	0.9995	0.4189	0.998	1
Bridge 13	1.9191	38.1395	0.0302	7.9905	0.3232	-0.0013	0.0542	0.2141	0.321	20
Bridge 14	2.1767	84.8880	1.0453	14.4218	0.5576	0.8231	0.8975	0.5095	0.559	15
Bridge 15	2.4323	46.8888	0.0028	4.5877	0.7187	0.2759	-0.0005	-0.0066	0.712	7
Bridge 16	1.6713	175.3344	0.6841	28.5078	0.0000	0.9942	0.7624	0.8310	0.009	22
Bridge 17	3.1746	209.3322	0.3864	55.2544	0.9577	0.9987	0.5488	0.9888	0.957	3
Bridge 18	2.2969	158.8862	0.2161	51.0398	0.6407	0.9890	0.3556	0.9792	0.642	12
Bridge 19	2.5810	65.9050	0.0958	8.7947	0.7886	0.6422	0.1735	0.2589	0.784	6
Bridge 20	1.9598	62.2164	0.4247	22.8345	0.3663	0.5898	0.5839	0.7384	0.369	19
Bridge 21	2.0216	84.8215	0.2768	25.7017	0.4270	0.8226	0.4321	0.7899	0.430	17
Bridge 22	2.3402	152.5967	0.2672	42.9085	0.6673	0.9860	0.4206	0.9500	0.668	10

# Multi-objective optimization

Bridges with assigned ranks –Risk neutral, equal weights

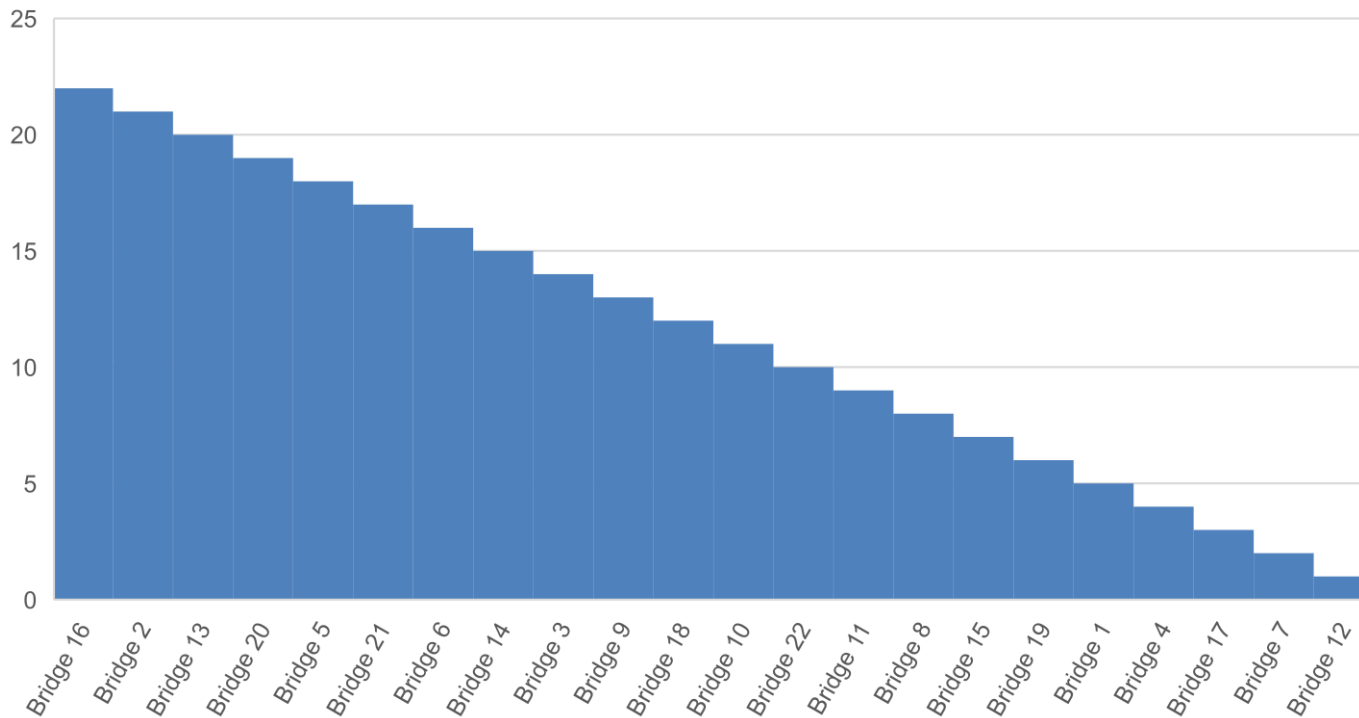

# Sensitivity analysis

- There are two subjective measures
  - Risk attitude of a decision maker
  - Weights assigned to each attribute
- We analyzed the effect of different risk attitude on bridge ranking while weights kept constant to 0.5
- We also analyzed the different weights assigned to four attributes to check effect on their result
- The developed MAUT tool was used for this purpose

# Robustness of MAUT –Risk attitude

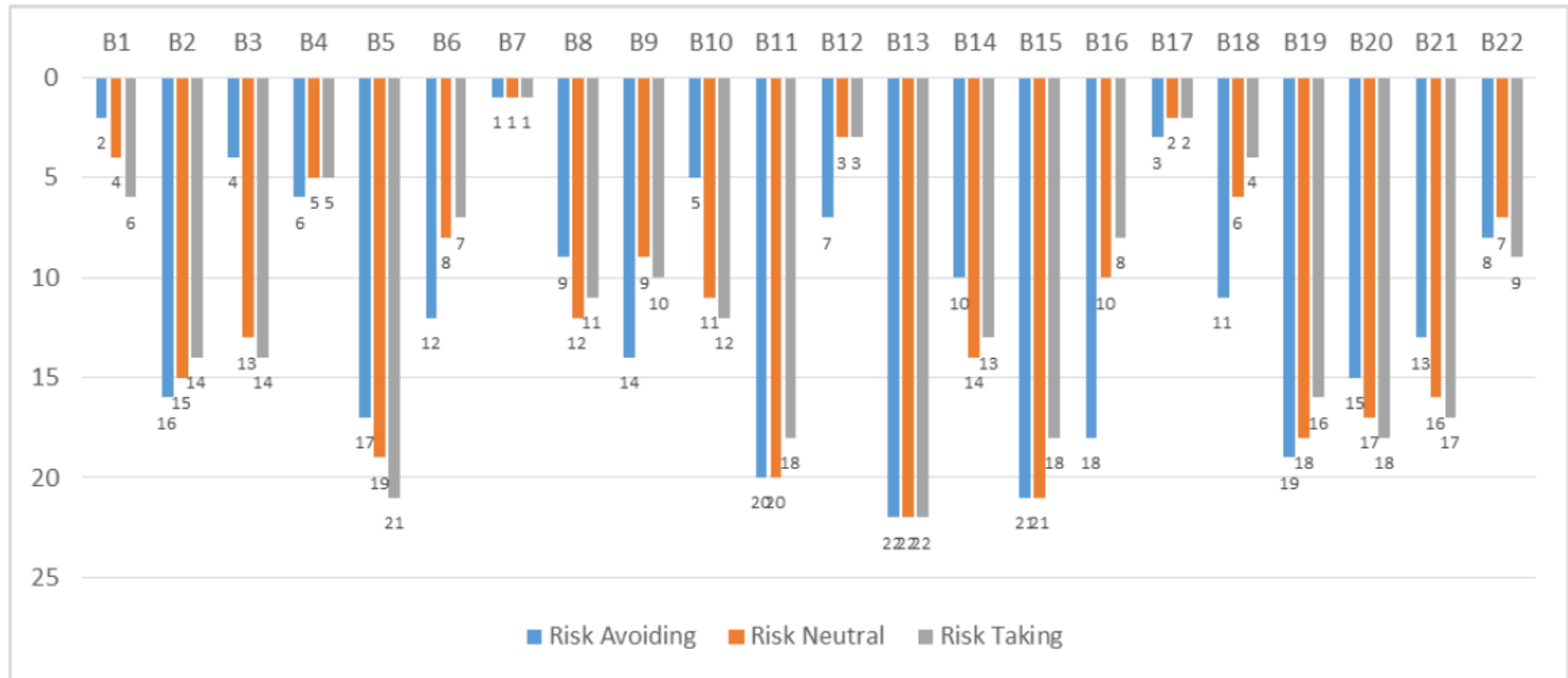

- There is very minor difference in bridges ranks see B7, B13, B22, and B2
- Risk avoiding attitude ranks bridges higher than risk taking see B2, B10, B8



# Robustness of MAUT –Weights

- We conducted single attribute analysis using the excel
  - The weights of only one attribute is changed while all the other attributes' weight were kept at 0.5

Weights	0.10	0.20	0.30	0.40	0.50	0.60	0.70	0.80	0.90
<b>Attributes</b>									
<b>Condition Index</b>	B7	B12	B12	B12	B12	B12	B12	B12	B12
<b>Maintenance Cost</b>	B7	B7	B7	B7	B7	B7	B7	B7	B17
<b>Environmental cost</b>	B12	B12	B12	B12	B12	B12	B12	B12	B12
<b>User delay cost</b>	B7	B7	B7	B7	B7	B7	B7	B7	B7

- The overall ranking doesn't change considerably

# Robustness of MAUT –Weights

- We conducted two-way attribute analysis using the excel
  - The weights of maintenance cost and condition index was changed in two-way analysis

MC	0.10	0.20	0.30	0.40	0.50	0.60	0.70	0.80	0.90
CI									
0.10	Bridge 7	Bridge 7	Bridge 7	Bridge 7	Bridge 7	Bridge 7	Bridge 7	Bridge 7	Bridge 7
0.20	Bridge 7	Bridge 7	Bridge 7	Bridge 7	Bridge 7	Bridge 7	Bridge 7	Bridge 7	
0.30	Bridge 7	Bridge 7	Bridge 7	Bridge 7	Bridge 7	Bridge 7	Bridge 7		
0.40	Bridge 7	Bridge 7	Bridge 7	Bridge 7	Bridge 7				
0.50	Bridge 7	Bridge 7	Bridge 7	Bridge 7					
0.60	Bridge 7	Bridge 7	Bridge 7						
0.70	Bridge 7	Bridge 7							
0.80	Bridge 7								
0.90									

# Conclusion

- The model supports the ranking of bridge inventory in a robust way, meaning that change of weights and risk doesn't significantly effect the overall ranking
- Instead of considering only one attribute, the model can consider number of attributes, translate them into utility values.
- The model incorporates the uncertainty and implements decision makers' preferences
- With the developed tool, large inventory of bridges can be ranked in only few seconds

Name.	Aggre. Condition	Maintenance cost	Environmental Cost	User delay cost	U(Agg. Cond)	U(MC)	U(En. Cost)	U(Uc)	Additive	Rank
Bridge 1	3.1050	144.8192	0.8888	39.7001	0.9444	0.9812	0.8506	0.9330	0.944	5
Bridge 2	1.8877	126.4059	0.2050	27.5019	0.2884	0.9623	0.3406	0.8172	0.293	21
Bridge 3	2.2086	115.6748	0.5749	25.5664	0.5810	0.9437	0.6984	0.7877	0.583	14
Bridge 4	3.1263	161.8502	1.1132	13.6378	0.9486	0.9902	0.9137	0.4804	0.947	4
Bridge 5	2.0000	68.1613	0.5303	12.4031	0.4064	0.6709	0.6679	0.4309	0.408	18
Bridge 6	2.1236	149.2116	0.2289	47.8949	0.5161	0.9841	0.3726	0.9699	0.519	16
Bridge 7	3.3559	196.7584	0.7081	57.7852	0.9866	0.9976	0.7748	0.9934	0.986	2
Bridge 8	2.4152	88.5989	1.2491	13.1125	0.7097	0.8459	0.9401	0.4599	0.710	8
Bridge 9	2.2194	45.8212	1.2567	35.8932	0.5888	0.2467	0.9414	0.9069	0.590	13
Bridge 10	2.3390	115.9342	0.4336	30.8020	0.6666	0.9443	0.5917	0.8590	0.668	11
Bridge 11	2.4152	39.4222	0.2321	12.6881	0.7097	0.0451	0.3767	0.4427	0.706	9
Bridge 12	3.4595	138.5160	1.8516	12.1170	1.0000	0.9761	0.9995	0.4189	0.998	1
Bridge 13	1.9191	38.1395	0.0302	7.9905	0.3232	-0.0013	0.0542	0.2141	0.321	20
Bridge 14	2.1767	84.8880	1.0453	14.4218	0.5576	0.8231	0.8975	0.5095	0.559	15
Bridge 15	2.4323	46.8888	0.0028	4.5877	0.7187	0.2759	-0.0005	-0.0066	0.712	7
Bridge 16	1.6713	175.3344	0.6841	28.5078	0.0000	0.9942	0.7624	0.8310	0.009	22
Bridge 17	3.1746	209.3322	0.3864	55.2544	0.9577	0.9987	0.5488	0.9888	0.957	3
Bridge 18	2.2969	158.8862	0.2161	51.0398	0.6407	0.9890	0.3556	0.9792	0.642	12
Bridge 19	2.5810	65.9050	0.0958	8.7947	0.7886	0.6422	0.1735	0.2589	0.784	6
Bridge 20	1.9598	62.2164	0.4247	22.8345	0.3663	0.5898	0.5839	0.7384	0.369	19
Bridge 21	2.0216	84.8215	0.2768	25.7017	0.4270	0.8226	0.4321	0.7899	0.430	17
Bridge 22	2.3402	152.5967	0.2672	42.9085	0.6673	0.9860	0.4206	0.9500	0.668	10



# Assessment of reliability for bridges exposed to local scour

**Nikola Tanasic** – Faculty of Civil Engineering, University of Belgrade, Serbia

**Rade Hajdin** – Faculty of Civil Engineering, University of Belgrade, Serbia



# OUTLINE

- **Approach in the Work Group 3**
- **Key data for consideration of flood impact in BM**
- **Failure modes and vulnerable zones**
- **Assessment of the reliability class**

## Approach in the WG3

- **WG1 survey review** = no systematic and comprehensive assessment of vulnerability to flooding – mostly visual inspection!
- **RAMSSH€EP – 4 KPIs are applied:**

Reliability = probability of failure

Safety = loss of life and limb  
(not related to structural failure)

**Snapshot assessment**

**Planning phase 2 - Maintenance**

Availability = traffic interruption due to maintenance activities

€conomy = costs over time for maintenance activities

## Key data for consideration of flood impact in BM

- **Three groups of data:**
  - **Exposure** to a flooding magnitude
  - **Resistance** of a bridge
  - **Consequences** of a failure
- A **risk** based approach

– Meteorology data – **an overkill for BM!**

**RISK**

– A flood magnitude + scenario

- Local scour at substructures (e.g. at a pier)

– Resistance of a bridge to the related soli removal

– Loss of life & limb + increase travel time&distance

**VULNERABILITY**



## Key data for the reliability assessment

- **Vulnerability** based approach

- Flood magnitude (+scenario)
  - Local scour at substructures
- Resistance of bridge to soli removal
- Loss of life & limb + increase of travel time&distance

Scope of the  
COST WG3

Failure  
modes

Probability of failure

KPI  
RELIABILITY

## Failure modes & vulnerability zones

- **Hazard scenario** e.g. pier affected by local scour
- **Failure mode**
  - Combined resistance of a soil-bridge system

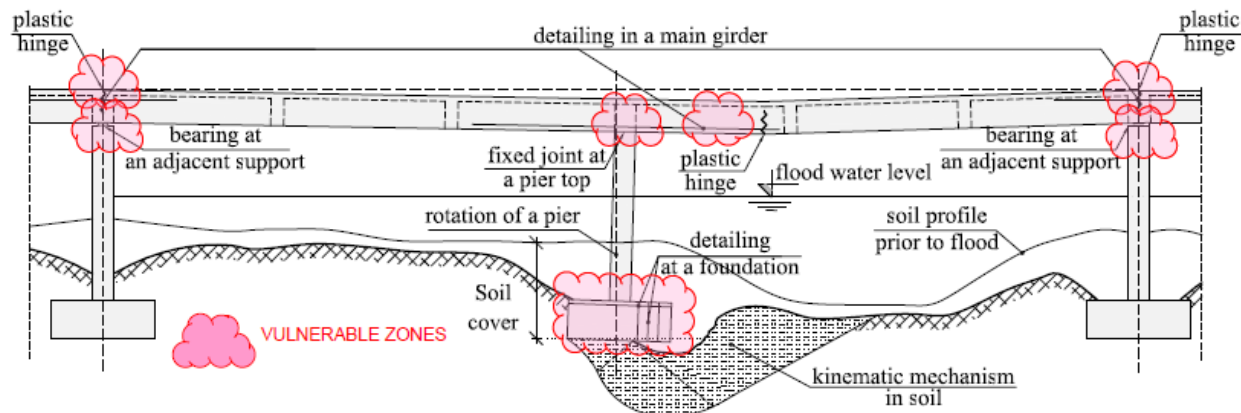

- **Vulnerable zones** = segments of a bridge which have a key role in resistance i.e. affect the probability of failure

# Reliability assessment

- **Semi-Quantitative approach**
- **Reliability class** is assessed via **Exposure class** and **Resistance class**
- **Exposure class:** account for the threat of a certain flooding scenario/magnitude and the related local scour potential
- **Resistance class:** account for diverse bridge types, their characteristic FMs and information update on condition in the vulnerable zones

## Exposure class

4	Yellow	Orange	Red	Purple	Purple
3	Yellow	Yellow	Yellow	Red	Purple
2	Green	Yellow	Yellow	Orange	Red
1	Green	Green	Green	Yellow	Orange
	1	2	3	4	5

Resistance class

Transition to a higher exposure class (vertical arrow from row 1 to row 3, column 3)

Transition to a higher resistance class (horizontal arrow from column 3 to column 4, row 3)

## Exposure class

- **Four classes (1 is low exposure, 4 is high)**
- **Adopted flooding magnitude e.g. 100-year flood**
  - **1st class:** Substructure is not in the floodplain
  - **2nd class:** Substructure is in contact with water
  - **3rd class:** Soil erosion takes place\*  
(\* based on a methodology to indirectly evaluate scour e.g. approaching velocity of flow > critical particle velocity)
  - **4th class:** Site conditions that can exacerbate scour (debris/ice potential, constrictions...) and/or history of flooding events

# Resistance class

## Bridge type/properties vs. failure modes

Bridge element	Attention	Resistance to a failure mode	Failure Mode
Affected substructure	Inadequate detailing or condition	Structure governed	1
Bearing/joint at the top of the affected substructure	Inadequate detailing or condition	Soil governed (low superstructure effect)	2
Bearings/joints at other substructures	Horizontal displacement free or restrained	Combined soil-bridge resistance	3
Main girder	Detailing	Combined soil-bridge resistance	3
Main girder	Detailing	Failure safe	4



**FM1 related**

**Pier washed away !**

## Resistance class

- **Five classes (1 is high resistance, 5 is low)**
  - **Innitial class is subject to bridge type&failure mode**
- **An example – bridges with shallow foundations**
  - **1st class:** Fail safe e.g **FM4** / Countermeasures in good condition
  - **2nd class:** Frame bridge, single span (e.g. **FM3**)
  - **3rd class:** Multiple span, fixed joints at the pier top (e.g. **FM3**)
  - **4th class:** Multiple simple beams (e.g. **FM2**)
  - **5th class:** Any bridge type with design flaw at substructures (**FM1**)

## Unknown data and transision between classes

- **Surveying is not an viable option**
  - **Unknown foundations** = adopt the resistance class related to bridge with shallow foundations
  - **Unknown soil cover** = +1 to the resistance class (i.e. lower resistance)
- **Deterioration of elements in vulnerable zones**
  - Resistance class update in accordance with failure modes
- **Update on the soil cover**
  - Indirect local scour evalaution

# Reliability class assessment

## Reliability class

	1	high
	2	medium
	3	low
	4	very low
	5	critical

## Transition to a higher resistance class

3	$L_s < 0.5 S_c$	three and more consecutive flooding events
4	$0.5 S_c > L_s > S_c$	two consecutive flooding events
5	$L_s > S_c$	one flooding event

\* $L_s$  = Indirectly evaluated local scour depth

\* $S_c$  = Soil cover is measured from the foundation level; for deep foundations it is the maximum height of soil cover at pile for a pile buckling failure mode

## Exposure class

Constriction of flow/Debris or Ice potential	4					
$V > V_c$	3					
Substructure in a floodplain	2					
Substructure not in a floodplain	1					
		1	2	3	4	5
Examples of initial resistance class (subject to bridge type/static system)		a) Any bridge system, fail safe b) Any bridge system, countermeasures in good condition	a) Frame single span bridges	a) Multiple span, fixed joint at the pier top	a) Multiple single span, pinned joint at the pier top	a) Foundation design error

**Resistance class**



## Conclusion

- **Semi-quantitative, practical approach account for:**
  - Soil erodibility (applied in the US)
  - Indirect local scour estimation (US, NZ, AUS, CAN, IND)
  - Failure modes **Novel !**
    - Effects of structure deterioration on reliability
- **Possible upgrade to a full quantitative approach**

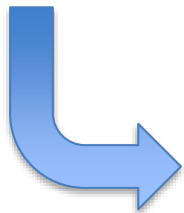

**More detailed differentiation  
between reliability thresholds**



**Thank you for the attention !  
Have a reliable journey !**





**TU1406**  
COST ACTION



**WG3, WG4 and WG5 WORKSHOP**

**Sustainable Bridge Management**

# **A COST-BASED QUALITY CONTROL PLAN FOR A SUSTAINABLE BRIDGE MAINTENANCE SCHEDULING**

**Mariano Angelo Zanini - University of Padova, Italy**

**Joan Ramon Casas – Technical University of Catalonia, Spain**

**Lorenzo Hofer - University of Padova, Italy**



**UNIVERSITÀ  
DEGLI STUDI  
DI PADOVA**



**UNIVERSITAT POLITÈCNICA  
DE CATALUNYA  
BARCELONATECH**

**23<sup>th</sup> – 24<sup>th</sup> November 2017  
Riga, Latvia**

# INTRODUCTION

- Roadway infrastructure asset management aims to **define the optimal maintenance strategies** required to keep assets at a desired performance level.
- Performance levels are usually assessed with the so-called **performance indicators (PIs)** representing an **objective metric wherewith a rational ranking of maintenance interventions** can be derived.
- **PIs** can be defined at different levels (i.e. component, system and network level) and can be **qualitative** or **quantitative** based.
- Technical indicators are usually considered also for making deterioration forecasts and thus define probable future deterioration scenarios for an infrastructural asset.
- Given a certain damage condition, a bridge owner can define the optimal restoration strategy to be carried out for extending the service life of an aged structure.

# INTRODUCTION

- In some cases, more than one solution can be developed, thus evidencing the need of identifying the best option. Hence, the ***selection of the best solution*** needs a ***set of indicators*** to be assessed and then compared for rationally support a choice.
- However, when realizing a restoration intervention, the execution of the different work phases implies a series of ***social, environmental and economic*** consequences that often are the most impacting in the decision making process.
- Non-technical *PIs* are often expressed with different metrics, so within the framework of a sustainable Quality Control (QC) plan there is the ***need to quantify with the same metric different performance indicators***, to be able **comparing alternative solutions and identifying the optimal one**, i.e. the one characterized by the lowest impact.

# INTRODUCTION

- At system level, the selection is usually made with a multi-objective optimization through multi-criteria decision-making (*MCDM*) or analytical hierarchy process (*AHP*).
- However, such kind of approaches are not able to clearly quantify in economic terms the environmental and social impacts associated with the adoption of a specific decision, since often points of the radar chart present dimensionless values that provide limited information about such impacts.
- Hence, it is fundamental to identify potential correlation models between different types of indicators, and **trying to express the outcomes in monetary terms**. In the following, a description of a ***purely cost-based system level approach*** and the use of a novel network level indicator called Financial Benefit Indicator (*FBI*) is described in detail.

# SYSTEM LEVEL ANALYSIS PROPOSAL

- The goal at *system level* is to identify the **best retrofit solution for and individual bridge among alternative options** (including also the do nothing solution) based on the assessment of technical and non-technical *PIs*.
- Results are clearly ***conditional to the deterioration state detected or forecasted*** with a deterioration model.
- A ***Markov chain deterioration model*** is adopted considering as technical *PI* a condition state *CS* ranging from 1 (best state) to 5 (worst state).
- The deterioration model allows defining a ***condition state probability vector  $CSP(t)$***  at a generic future time instant  $t$  on the basis of the actual condition state probability vector  $CSP(t_0)$ .
- **Three** possible decisions: **DO NOTHING**, **MUST REHABILITATE**, **COULD REHABILITATE**.



# SYSTEM LEVEL ANALYSIS PROPOSAL

- The proposed system level analysis proposal. The safety goal can be expressed in terms of **condition state probability threshold**.

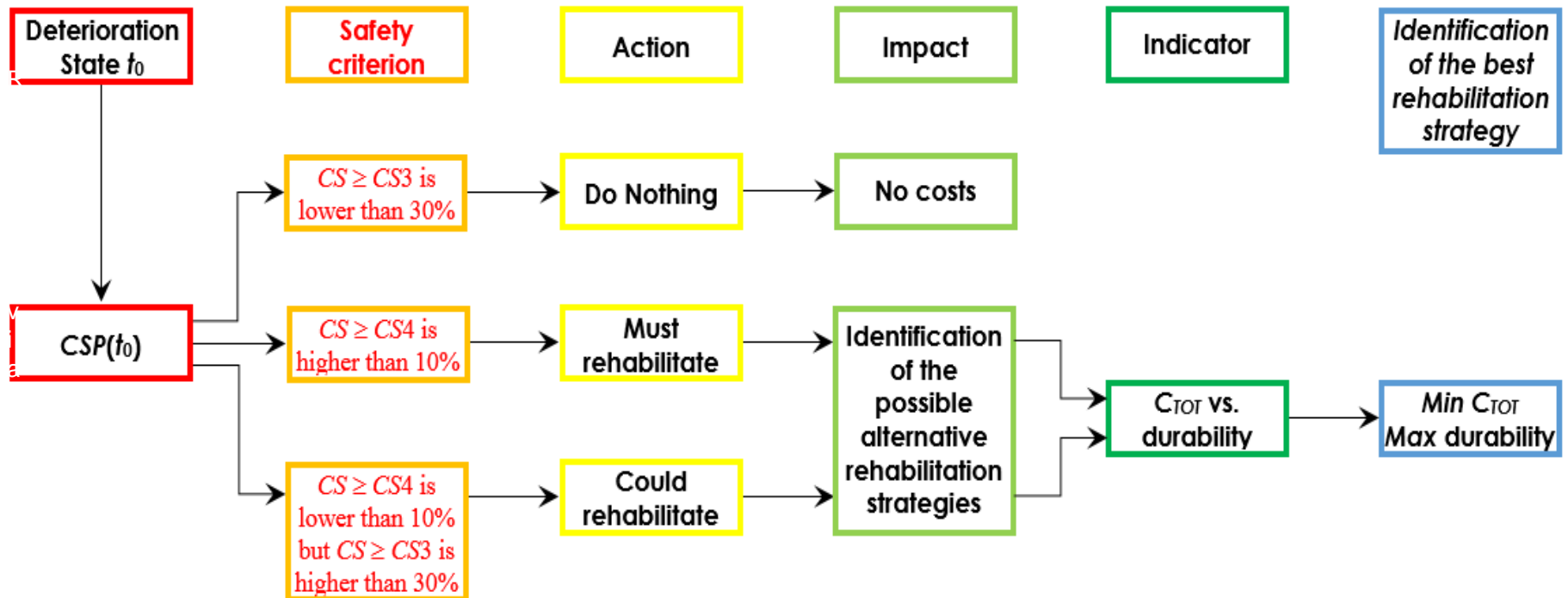

# SYSTEM LEVEL ANALYSIS PROPOSAL

- If a “do nothing” strategy is followed, *any cost is sustained* whereas the *deterioration state remain unchanged and will be subject to worsening as soon as time will pass.*

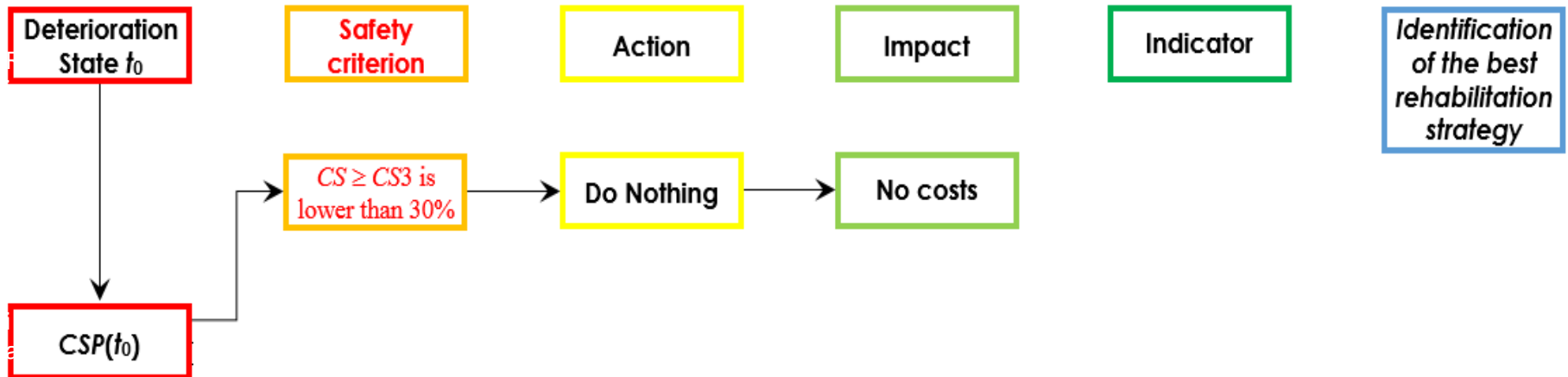

# SYSTEM LEVEL ANALYSIS PROPOSAL

- If an **urgent rehabilitation is required** ( $CS \geq CS4$  higher than 10%), it is necessary to identify the **best rehabilitation solution** to be implemented among a set of alternative ones.

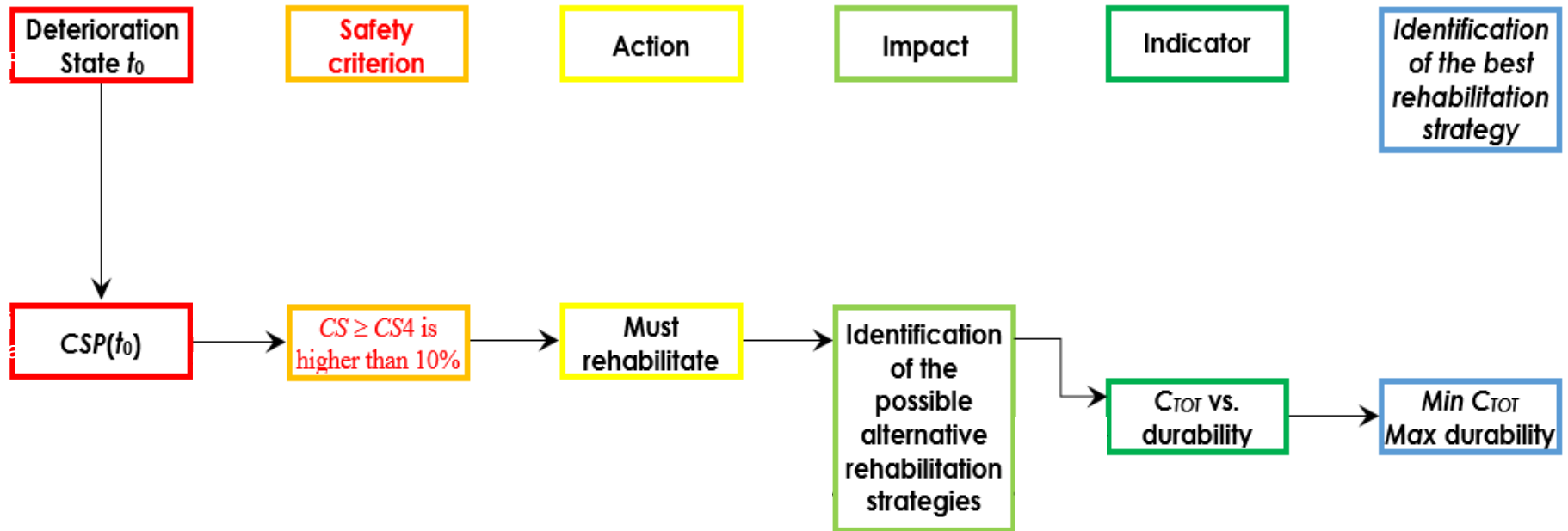

# SYSTEM LEVEL ANALYSIS PROPOSAL

- Usually owners take only into account the direct cost to perform the rehabilitation and its durability, whereas the development of a sustainable QC (*Quality Control*) plan requires involving also indirect costs like those associated with non-technical indicators in the decision making process. In this regard, it is necessary to assume ***suitable consequence functions*** for monetizing ***technical*** but also ***environmental*** and ***social*** impacts associated with the execution of each alternative rehabilitation strategy.
- In addition, it is crucial to estimate for each rehabilitation strategy an effective time duration (i.e. quantifying its durability). ***Durability*** can be viewed as the ***time span from the execution of the rehabilitation to the time instant in which the safety criterion is not again fulfilled.***

# SYSTEM LEVEL ANALYSIS PROPOSAL

- Roadway owners usually allocate a fixed yearly amount in their budget income for maintenance interventions, that have to be first used for the bridges that not fulfill the safety criterion ( $CS \geq CS_4$  is higher than 10%), and in case of monetary surplus can be used for implementing such further possible rehabilitations.
- Supposing to have an asset of  $n$  bridges that at  $t_0$  are characterized by different deterioration states (i.e.  $n$   $CSP(t_0)$  vectors). A subset of  $r$  structures is not fulfilling the safety criterion and for them the owner has to implement the **“MUST REHABILITATE”** action, whereas another subset of  $s$  bridges is in good condition and, therefore, the **“DO NOTHING”** action is followed.
- The remaining  $n-(r+s)$  structures are characterized by an intermediate deterioration level, involving a possible, but not urgent rehabilitation (i.e. **“COULD REHABILITATE”** action).

# SYSTEM LEVEL ANALYSIS PROPOSAL

- If a possible but not urgent rehabilitation condition characterizes a bridge ( $CS \geq CS4$  lower than 10% but  $CS \geq CS3$  higher than 30%), it is necessary to quantify its financial benefit via the *FBI* calculation.

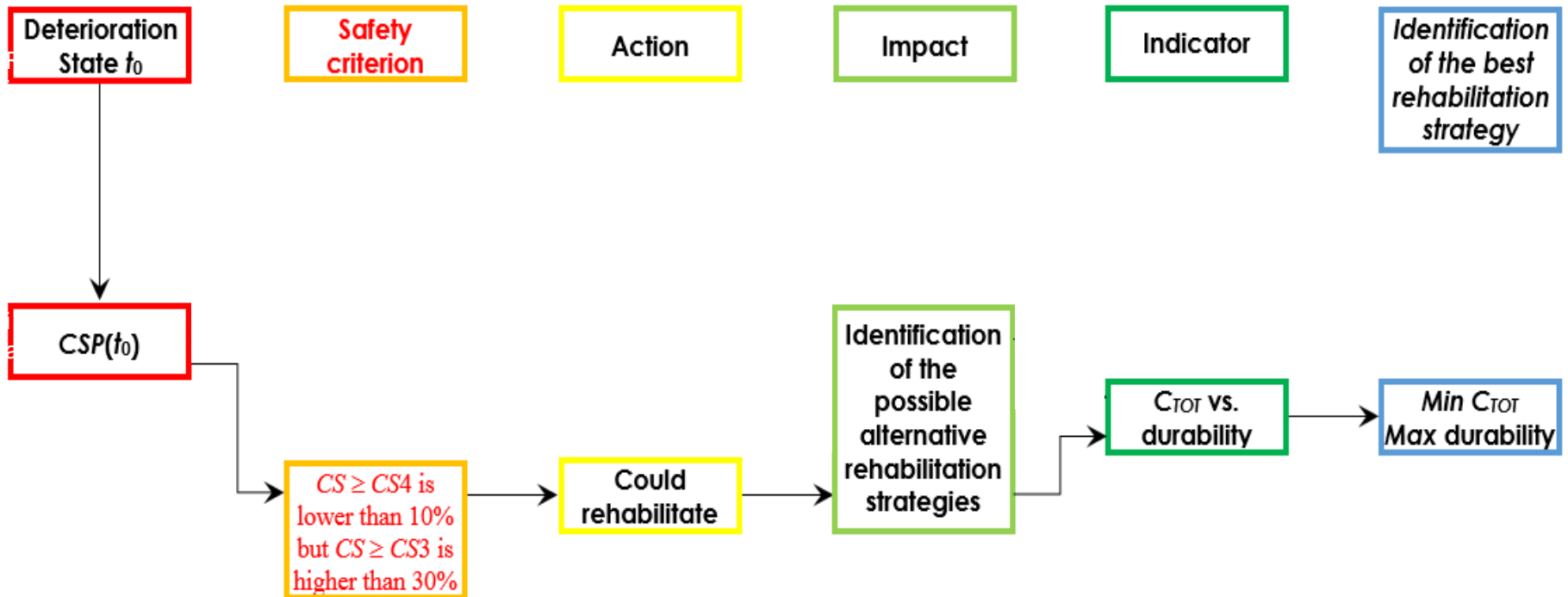

# SYSTEM LEVEL ANALYSIS PROPOSAL

- The *FBI* (*Financial Benefit Indicator*), which is **representative of the financial benefit** (i.e. saved anticipated future impacts) **associated with the decision of performing now a rehabilitation** (even if not urgently needed), with respect to the execution of that intervention in a future year when the safety criterion will not be satisfied).
- The **time interval that is still available before the rehabilitation must be performed**,  $\Delta t_{saf}$ , has to be estimated with a deterioration model for the existing bridge. At that time maintenance costs have to be estimated. Then, maintenance costs have to be estimated also for the case in which a rehabilitation is performed now.
- The **ratio between maintenance costs without/with the implementation of a rehabilitation is the FBI**, i.e. **an indicator of the avoided maintenance costs at  $\Delta t_{saf}$  years due to the “anticipated” execution at  $t_0$**  of a not urgently needed rehabilitation strategy.

# ILLUSTRATIVE EXAMPLE

- An illustrative application of the cost-based system level decision process flow is presented, considering a two-span prestressing concrete bridge with deck area of 600 m<sup>2</sup> (10 m width and 30 m + 30 m length) and a frame pier.
- The replacement unit cost has been assumed equal to 800 €/m<sup>2</sup>, leading to a total absolute replacement cost value of 480000€.
- A Markov chain deterioration model for the bridge is assumed considering a set of  $\theta_{ij,existing}$  sojourn time expected values.

Expected sojourn time $\theta_{10}$	$\theta_{12}$ [years]	$\theta_{23}$ [years]	$\theta_{34}$ [years]	$\theta_{45}$ [years]
<b>Existing</b>	10	16	14	10
<b>Rehabilitation strategy A</b>	14	19	16	11
<b>Rehabilitation strategy B</b>	10	16	12	7

- Three different initial condition state probability vectors.



# ILLUSTRATIVE EXAMPLE

- Three different initial condition state probability vectors.

$$CSP1(t_0) = [0.5 \quad 0.34 \quad 0.15 \quad 0.01 \quad 0]$$

Safety criteria  $CS_{\geq CS4} = 0.01$  (<10%),  $CS_{\geq CS3} = 0.16$  (<30%)

DO NOTHING

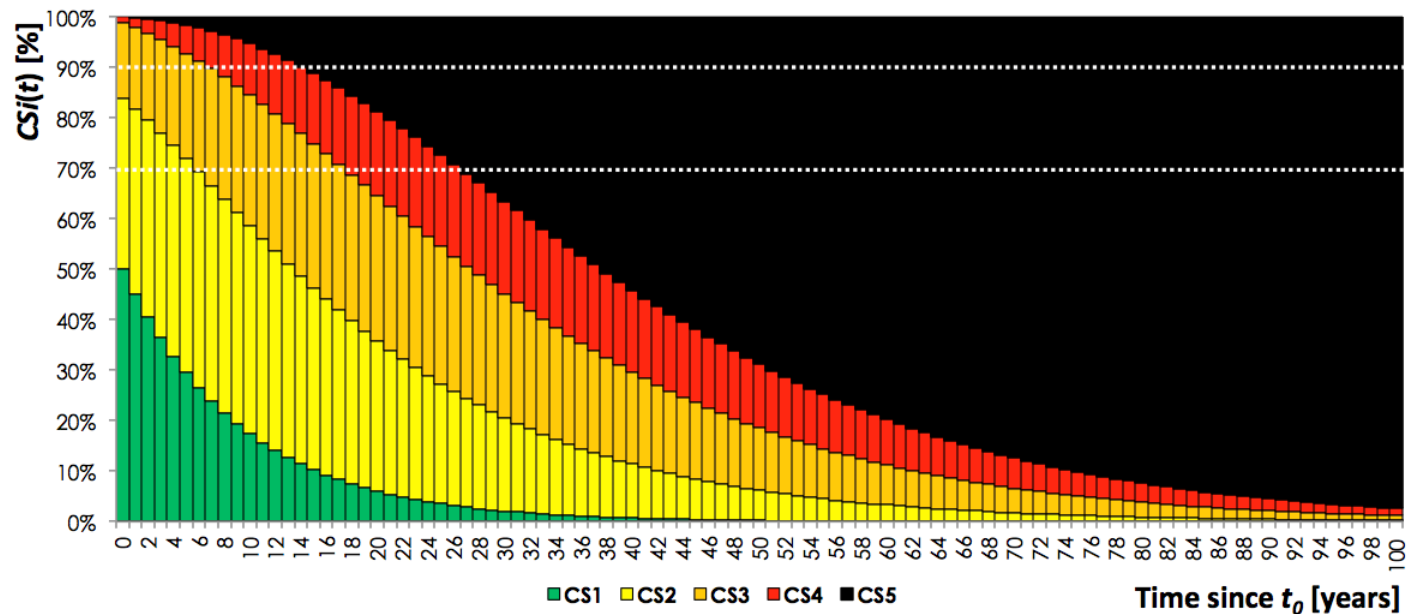

# ILLUSTRATIVE EXAMPLE

- Three different initial condition state probability vectors.

$$CSP2(t_0) = [0.13 \quad 0.27 \quad 0.39 \quad 0.17 \quad 0.04]$$

Safety criteria  **$CS \geq CS4 = 0.21$  (<10%),  $CS \geq CS3 = 0.60$  (<30%)**

MUST  
REHABILITATE

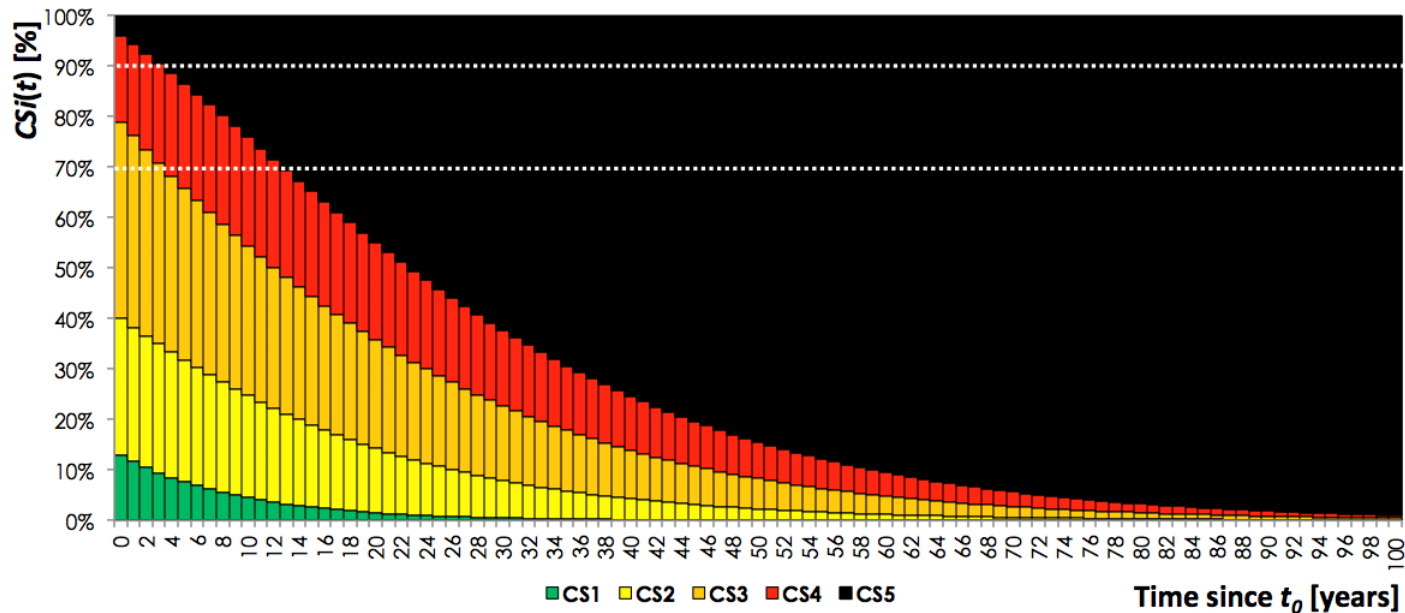

# ILLUSTRATIVE EXAMPLE

- Two alternative rehabilitation strategies (A,B).

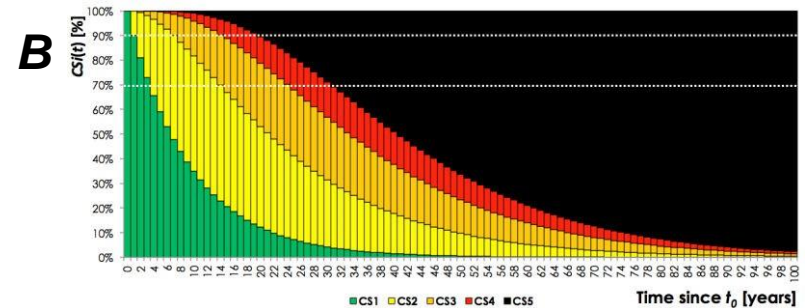
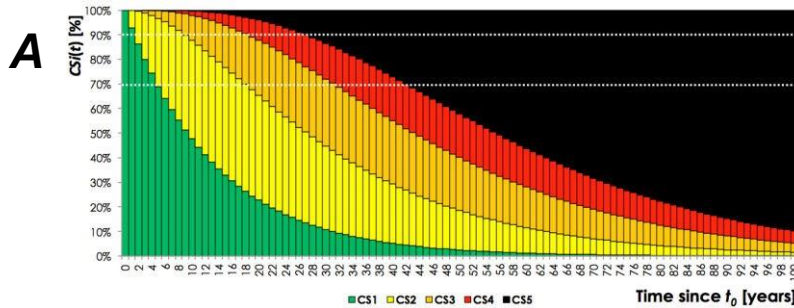

- Two Gantts (C,D) for a total of 4 alternatives, for each cost estimates.

$X_{\text{PII},\mu}(\text{CS})$	$X_{\Sigma 1}$	$X_{\Sigma 2}$	$X_{\Sigma 3}$	$X_{\Sigma 4}$	$X_{\Sigma 5}$
$X_{\text{TEX},\mu,A\&X}(\text{CS})$	0	0.03	0.08	0.28	1
$X_{\text{ENG},\mu,A\&X}(\text{CS})$	0	0.01	0.10	0.15	0.4
$X_{\Sigma\text{OX},\mu,A\&X}(\text{CS})$	0	0.02	0.13	0.80	1.3
$X_{\text{TEX},\mu,A\&\Delta}(\text{CS})$	0	0.03	0.08	0.28	1
$X_{\text{ENG},\mu,A\&\Delta}(\text{CS})$	0	0.04	0.15	0.24	0.5
$X_{\Sigma\text{OX},\mu,A\&\Delta}(\text{CS})$	0	0.05	0.20	1.1	1.9
$X_{\text{TEX},\mu,B\&X}(\text{CS})$	0	0.02	0.05	0.20	1
$X_{\text{ENG},\mu,B\&X}(\text{CS})$	0	0.01	0.10	0.15	0.4
$X_{\Sigma\text{OX},\mu,B\&X}(\text{CS})$	0	0.02	0.13	0.80	1.3
$X_{\text{TEX},\mu,B\&\Delta}(\text{CS})$	0	0.02	0.05	0.20	1
$X_{\text{ENG},\mu,B\&\Delta}(\text{CS})$	0	0.04	0.15	0.24	0.5
$X_{\Sigma\text{OX},\mu,B\&\Delta}(\text{CS})$	0	0.05	0.20	1.1	1.9
<b>Rehabilitation strategy #</b>	$C_{\text{TOT},\mu-\sigma}(t_0)$	$C_{\text{TOT},\mu}(t_0)$	$C_{\text{TOT},\mu+\sigma}(t_0)$		
A&X	0.384	0.454	0.524		
A&\Delta	0.515	0.612	0.708		
B&X	0.359	0.426	0.493		
B&\Delta	0.490	0.584	0.677		

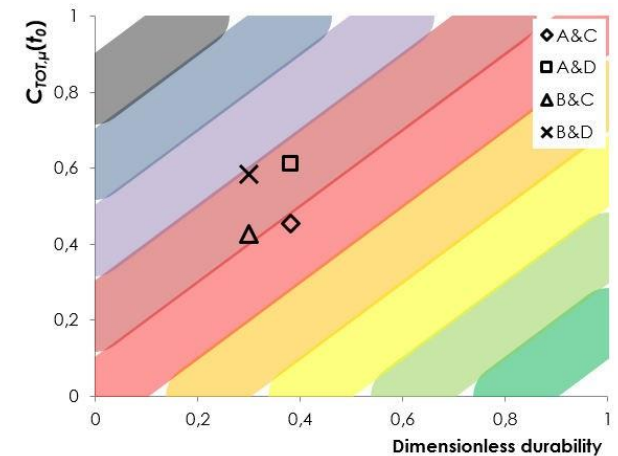

Ri g a , L a t v i a

# ILLUSTRATIVE EXAMPLE

- Three different initial condition state probability vectors.

$$CSP3(t_0) = [0.27 \quad 0.42 \quad 0.28 \quad 0.03 \quad 0.00]$$

Safety criteria  $CS_{\geq CS4} = 0.03$  (<10%),  **$CS_{\geq CS3} = 0.31$**  (<30%)

COULD  
REHABILITATE

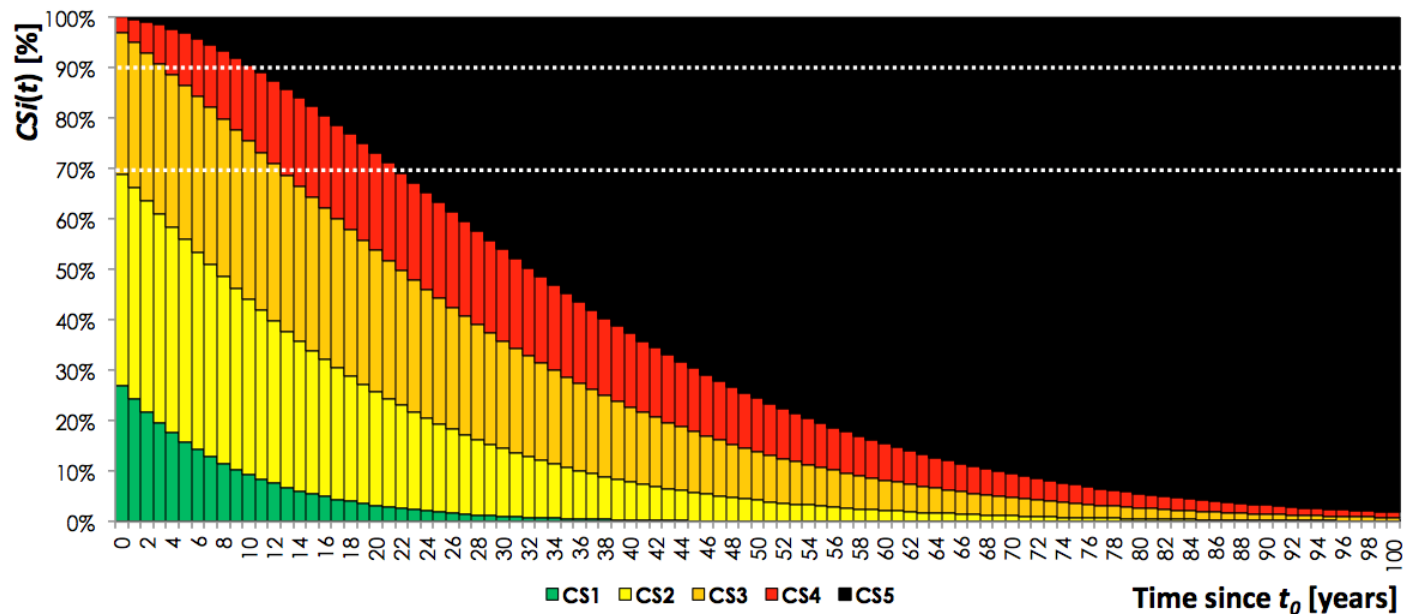

# ILLUSTRATIVE EXAMPLE

- Mean, mean $\pm$ sigma total cost curves over time for the existing bridge and A&C rehabilitation.

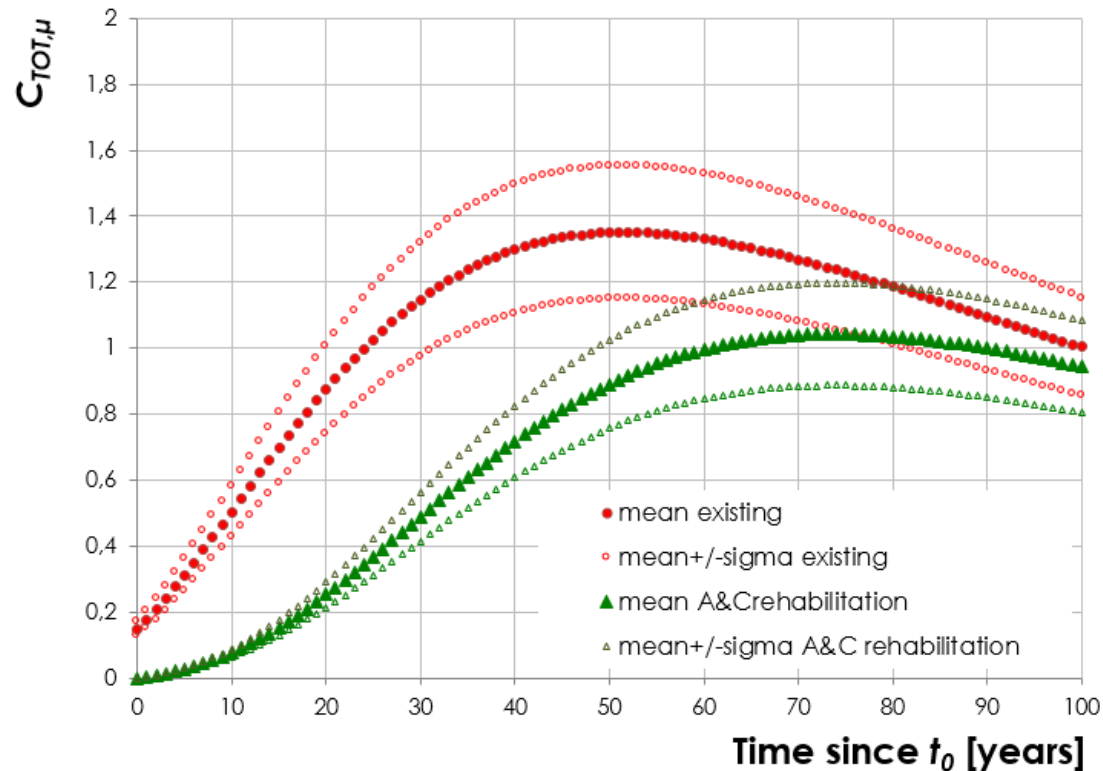

# ILLUSTRATIVE EXAMPLE

- Mean, mean $\pm$ sigma *FBI* (*Financial Benefit Indicator*) for a  $\Delta t_{saf} = 4$  years.

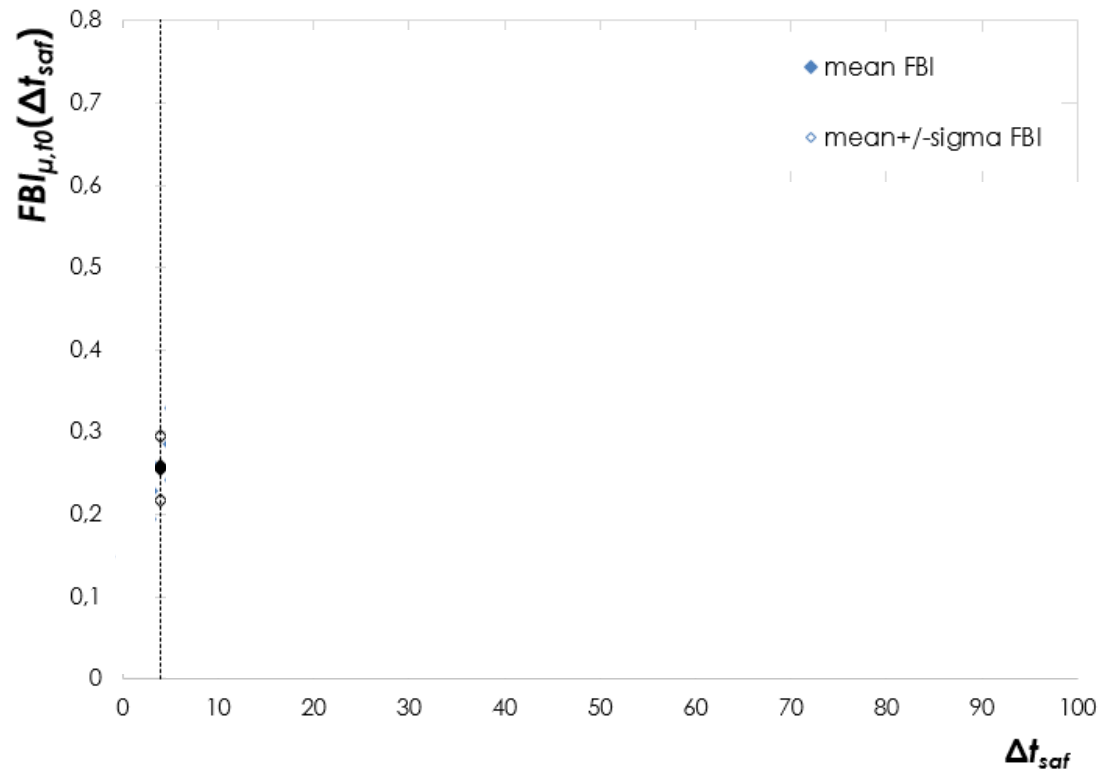

# CONCLUSIONS

- The  $FBI_{\mu,t_0}$ ,  $FBI_{\mu-\sigma,t_0}$  and  $FBI_{\mu+\sigma,t_0}$  values are plotted as a function of  $\Delta t_{saf}$  evidencing the values for the specific case under analysis with  $\Delta t_{saf}$  of 4 years, respectively equal to 0.257, 0.218 and 0.296.
- Summarizing, given the deterioration state at  $t_0$ , the execution of a A&C rehabilitation strategy could lead to a mean financial benefit  $FBI_{\mu,t_0}$  (i.e. **saved anticipated future costs**) of 0.257 replacement units, equivalent to an absolute value of 123360€.
- Such absolute benefit **will be compared with  $FBI_{\mu,t_0}$  values obtained for all the bridges of an asset** in a “**COULD REHABILITATE**” situation, thus defining the **priority ranking** based on a  $FBI_{\mu,t_0}$  metric.



**THANKS FOR YOUR ATTENTION!**

[WWW.TU1406.EU](http://WWW.TU1406.EU)





# BRIDGE QUALITY APPRAISAL METHODOLOGY: APPLICATION IN THE STRIMONAS BRIDGE CASE STUDY

**Dimosthenis Kifokeris** – Aristotle University of Thessaloniki, Greece

**Yiannis Xenidis** – Aristotle University of Thessaloniki, Greece

**Panagiotis Panetsos** – Egnatia Odos S.A., Greece

**José António Campos e Matos** – University of Minho, Portugal

**Luís Bragança** – University of Minho, Portugal



# GENERAL ADVANTAGES IN THE USE OF *PIs*

- To-the-point expression and measurement of crucial bridge quality performance aspects (e.g. sustainability, serviceability, and safety)
- Measurement diversity – applicable data obtained in various ways (e.g. field measurements, laboratory experiments, and expert input)
- Aiding in decision-making for lifecycle provision, along with current quality assessment
- Utilization of existent lessons-learned from *PIs*' implementation in project management

# DRAWBACKS IN THE USE OF *PIs* FOR BRIDGE QC

- No correlation of **measured** *PI* values with their benchmark values of **conventional** and **best achievable** performance. Such correlation could allow a deeper understanding of:
  - The nature of the *PIs*
  - The *PIs*' context within quality performance aspects (*KPIs*)
  - The ways of improving *KPIs*
- Relative ambiguity of deliverables, due to the *PIs*' diversity

# HOW THE PRESENTED METHODOLOGY AIMS TO ALLEVIATE SUCH DRAWBACKS

- By incorporating benchmark *PI* values
- By producing concise quality performance values for the *KPIs*, the components, and the whole bridge (system level)
- By monitoring the intermediate procedural levels through a clear step-by-step methodological structure

# METHODOLOGY ASPECTS

## The methodology combines:

- The research findings of TU1406 WG1 regarding:
  - The *PIs*, clustered into:
    - General defects
    - Material properties
    - Equipment condition
    - Structural geometry changes
    - Bearing capacity
    - Structural integrity and joints defects
    - Design and construction sequence attributes
    - Dynamic behavior
    - Auxiliary characteristics
    - Component cost and importance
  - The *KPIs*:
    - Availability
    - Costs
    - Durability
    - Environment
    - Health
    - Maintainability
    - Politics
    - Rating/inspection
    - Reliability
    - Safety
    - Security

# METHODOLOGY ASPECTS

- Real *PIs*' values obtainment (e.g. through field measurements, observations etc.)
- Expert input solicitation methods:
  - Interviews (for the obtainment of *PIs*' benchmark values of conventional and best practice)
  - Questionnaire survey with Likert-scale questions (for the importance rating of *PIs*, *KPIs*, and bridge components)
- The AHP (Analytical Hierarchy Process), and an appropriate AHP results consolidation methodology
- The SB (Sustainable Building) methodology (with adaptations and modifications)

# METHODOLOGY STRUCTURE

1.  $k$  ( $k=\{1,2,\dots,n\}$ ) experts rate the importance of the  $g$  *PIs* ( $g=\{1,2,\dots,l\}$ ) connected to each of the  $h$  *KPIs* ( $h=\{1,2,\dots,m\}$ ) using a 5-point Likert scale (1: not important, to 5: very important)
2. Processing of each of the  $k$  experts' input via the Row Geometric Mean Method (RGMM) variation of the AHP, to calculate  $w_{PI_{gh},k}$  (the relative weight of the  $g^{\text{th}}$  *PI* corresponding to the  $h^{\text{th}}$  *KPI* according to the  $k^{\text{th}}$  expert):

$$r_{kh,i} = \exp \left[ \frac{1}{g} \sum_{j=1}^g \ln(A_{kh_{ij}}) \right] = \left( \prod_{i=1}^g A_{kh_{ij}} \right)^{1/g}$$

(calculation of the priority values  $r_{kh,i}$  of the square pairwise comparison matrix  $A_{kh}$ )

# METHODOLOGY STRUCTURE

$$P_{kh,i} = \frac{r_{kh,i}}{\sum_{i=1}^g r_{kh,i}} \quad (\text{normalization of priority values})$$

$$GCI = \frac{2\sum_{i<j} \ln(A_{kh_{ij}}) - \ln\left(\frac{P_{kh,i}}{P_{kh,j}}\right)}{(g-1)(g-2)} \quad (\text{Geometric Consistency Index of the normalized priority values})$$

If **GCI** < **0.31** (for  $g = 3$ ), < **0.35** (for  $g = 4$ ), or < **0.37** (for  $g > 4$ ), then

$$W_{PI_{gh},k} = P_{kh,i}$$



# METHODOLOGY STRUCTURE

3. Weighted aggregation of all  $w_{PI_{gh},k}$  for all  $n$  experts, to obtain the final weights  $W_{PI_{gh}}$  (the weights of each one of the  $g$   $PI$ s related to the  $h^{\text{th}}$   $KPI$  according to all experts). This is done via the Weighted Geometric Mean Method (WGMM) and the Eigenvector Method (EVM) variation of the AHP:

$$C_{h_{ij}} = \exp \frac{\sum_{h=1}^g \ln(A_{kh_{ij}})}{\sum_{h=1}^g w_{PI_{gh},k}} \quad (\text{WGMM elements of the consolidated matrix } C_h)$$

$$CR = \frac{\lambda_{\max} - g}{2.7699l - 4.3513 - g} \quad (\text{consistency check of the max eigenvector})$$

# METHODOLOGY STRUCTURE

If  $CR \leq 0.10$ , and having calculated the priority vectors  $S_{h,i}$ , then

$$W_{PI_{gh}} = S_{h,i}$$

4. Robustness check of the consolidated results through the consensus indicator  $S^*: [0,1]$  (the threshold is  $S^* \geq 0.65$ ):

$$S^* = \left[ (1 / \exp(H_\beta)) - \exp(H_{\alpha \min}) / \exp(H_{\gamma \max}) \right] / \left[ 1 - \exp(H_{\alpha \min}) / \exp(H_{\gamma \max}) \right]$$

where

$$H_\alpha = \frac{1}{n} \sum_{k=1}^n \sum_{g=1}^l (-p_{gk} \ln(p_{gk}))$$

(Shannon alpha entropy)

# METHODOLOGY STRUCTURE

$$H_{\gamma} = \sum_{k=1}^n (-\bar{p}_k \ln \bar{p}_k) \quad (\text{Shannon gamma entropy, with } \bar{p}_k = \frac{1}{l} \sum_{g=1}^l p_{gk})$$

$$H_{\beta} = H_{\gamma} - H_{\alpha} \quad (\text{Shannon beta entropy})$$

$$H_{\alpha \min} = -\frac{c_{\max}}{l + c_{\max} - 1} \ln \left( \frac{c_{\max}}{l + c_{\max} - 1} \right) - (l-1) \frac{1}{l + c_{\max} - 1} \ln \left( \frac{1}{l + c_{\max} - 1} \right) \quad (\text{min } H_{\alpha})$$

$$H_{\gamma \max} = (l-n) \left( -\frac{1}{c_{\max} + l - 1} \right) \ln \left( \frac{1}{c_{\max} + l - 1} \right) - \left( \frac{n + c_{\max} - 1}{l + c_{\max} - 1} \right) \ln \left( \frac{n + c_{\max} - 1}{n(l + c_{\max} - 1)} \right) \quad (\text{max } H_{\gamma})$$

for  $c_{\max} = 5$ , due to the 5-point Likert scale

# METHODOLOGY STRUCTURE

5. Repeating of steps 1-4 to calculate  $W_{KPI_{hu}}$  (namely, the relative weights of the  $h$  *KPIs* corresponding to the  $u^{\text{th}}$  bridge component, where  $u=\{1,2,\dots,v\}$ ), and  $W_{comp_u}$  (namely, the relative weights of the  $u$  components connected to the bridge at the system level)
  
6. Obtainment of the real value  $P_{gh}$ , conventional practice value  $P_{gh^*}$ , and best practice value  $P_{gh}^*$ , for the  $g^{\text{th}}$  *PI* connected to the  $h^{\text{th}}$  *KPI*
  
7. Normalization of the *PI* values in  $[0,1]$ : 
$$P_{gh}^{norm} = \frac{P_{gh} - P_{gh^*}}{P_{gh}^* - P_{gh^*}}$$

# METHODOLOGY STRUCTURE

8. Derivation of the calibrated normalized values  $P_{gh}^{norm*}$  through the following rules:

- If  $P_{gh}^{norm} > 1.2$ , then  $P_{gh}^{norm*} = 1.2$
- If  $P_{gh}^{norm} < -0.2$ , then  $P_{gh}^{norm*} = -0.2$
- If  $P_{gh} = P_{gh*} = P_{gh}^*$ , then  $P_{gh}^{norm*} = 1$
- If  $P_{gh} \neq P_{gh*} = P_{gh}^*$ , then  $P_{gh}^{norm*} = 0$
- In any other case,  $P_{gh}^{norm*} = P_{gh}^{norm}$

# METHODOLOGY STRUCTURE

9. Calculation of the quality performance of the  $h^{\text{th}}$  *KPI* related to the  $u^{\text{th}}$  component:

$$Q_{KPI_{hu}} = \sum_{g=1}^l W_{PI_{gh}} \cdot P_{gh}^{norm} *$$

10. Calculation of the quality performance of the  $u^{\text{th}}$  component:

$$Q_{comp_u} = \sum_{h=1}^m W_{KPI_{hu}} \cdot Q_{KPI_{hu}}$$

11. Calculation of the quality performance of the whole bridge at the system level:

$$Q_{bridge} = \sum_{u=1}^v W_{comp_u} \cdot Q_{comp_u}$$

# APPLICATION IN THE STRIMONAS BRIDGE CASE STUDY

- Located at coordinates 40°48'4"N, 23°51'20"E
- Intersects the Greek part of the Strimonas river
- Part of the 670-km-long Egnatia Motorway designed, constructed and operated by Egnatia Odos S.A.



# APPLICATION IN THE STRIMONAS BRIDGE CASE STUDY

- Constructed in 1987
- Length: 240 m
- Pavement's width (including the sidewalks): 12 m (two traffic lanes)
- Eight 30-m-long spans
- Deck comprises from five precast prestressed concrete T beams
- Founded on the Strimonas' riverbed with multi-column piers through piles
- Upon piers, deck is simply supported through NB1 elastomeric bearings
- Elastomeric expansion joints of the T50 type
- Identified components: **abutments, piers, superstructure, safety railings, sidewalks, pavement, and drainage system**



# APPLICATION IN THE STRIMONAS BRIDGE CASE STUDY

- Identity of the questionnaire survey among Egnatia Odos S.A. experts, conducted for the importance ratings

**Table 1.** Identity of the questionnaire survey

Respondents' attributes	Percentage (%)
Researcher	33.3
Owner	33.3
External partner	33.3
Respondents' expertise	Percentage (%)
Maintenance	100
Analytical research	66.7
Experimental research	33.3
Design	33.3
Years of experience*	Percentage (%)
[5 - 10]	66.7
[15 - 20]	33.3

\*Intervals are determined based on the actual values reported by the respondents in the survey

# APPLICATION IN THE STRIMONAS BRIDGE CASE STUDY

- Identified and discretized *PIs* for the Strimonas Bridge

Table 2. Identified and discretized *PIs* for the Strimonas Bridge

Identified <i>PIs</i>	<i>KPIs</i>														Components					
	A	C	D	E	H	I	M	P	R	S	Se	AB	PI	SU	SR	SI	PA	DS		
Approach slab settlement	X	X				X				X	X		X	X	X			X		
Asphalt pavement cracking	X	X				X				X								X		
Asphalt pavement wearing and tearing	X	X				X				X								X		
Asphalt pavement wheel tracking/undulation	X	X				X				X								X		
Bearings deformation	X	X				X			X	X		X	X	X						
Bearings displacement	X	X				X			X	X				X	X					
Carbonation depth	X	X	X	X		X						X	X	X			X			
Carrying capacity factor										X		X	X	X						
Chloride content	X	X	X	X		X						X	X	X	X	X		X		
Concrete cover (insufficient)	X	X	X	X		X			X	X		X	X	X	X		X			
Condition rating	X	X				X				X		X	X	X	X	X	X	X		
Corrosion (overall)	X	X	X		X	X			X	X					X	X		X		
Corrosion related to prestressing steel	X	X	X		X	X			X	X				X						
Corrosion stains related to protective coating	X	X	X			X				X		X	X	X	X	X		X		
Corrosion related to reinforcement steel	X	X	X		X	X			X	X		X	X	X				X		
Crack length (component-specific causes)	X	X				X						X	X	X	X			X		
Crack orientation (component-specific causes)						X						X	X	X	X			X		
Crack spacing (component-specific causes)						X			X			X	X	X	X			X		
Crack width (component-specific causes)	X	X	X			X			X	X		X	X	X	X			X		
Cracks related to origin (e.g. due to settlement)						X			X	X		X	X	X	X			X		
Damping									X	X		X	X	X						
Deterioration of protective coatings						X						X	X	X	X	X		X		
Ductility							X		X	X		X	X	X	X					
Frequency									X	X		X	X	X						
Grouting deficiency	X	X	X			X			X	X				X		X				
Inadequate clearance and accessibility							X					X	X	X				X		
Insufficient height of railing (safety barrier)			X			X				X					X			X		
Joint deterioration	X	X				X			X	X		X	X	X						
Loss of section	X	X				X			X	X		X	X	X	X	X		X		
Misalignment						X			X	X		X	X	X	X	X				
Pitted corrosion				X		X			X	X		X	X	X	X					
Priority repair ranking	X	X					X					X	X	X	X	X	X	X		
Probability of failure									X			X	X	X	X	X	X	X		
Remaining service life			X	X								X	X	X	X	X	X	X		
Sag/deformation/denivelation							X			X	X	X	X	X	X			X		
Settlement							X		X	X		X	X	X	X					
Sum of costs for repair of individual damages			X									X	X	X	X	X	X	X		
Water penetrability				X		X			X	X		X	X	X						
Waterproofing deterioration/loss	X	X				X						X	X	X						

Note: A = Availability; C = Costs; D = Durability; E = Environment; H = Health; I = Inspection/rating; M = Maintainability; P = Politics; R = Reliability; S = Safety; Se = Security; AB = Abutments; PI = Piers; SU = Superstructure; SR = Safety railings; SI = Sidewalks; PA = Pavement; DS = Drainage system

# APPLICATION IN THE STRIMONAS BRIDGE CASE STUDY

- Example of the obtained triplets of the  $PI$  values ( $PI$ s expressing the  $KPI$  "Durability" in relation to the bridge's superstructure)

**Table 3.** All values of the  $PI$ s expressing  $KPI$  "Durability" in relation to Strimonas Bridge's superstructure

$PI$ s	Measurement units	$P_{gh}$	$P_{gh}^*$	$P_{gh}^*$	$P_{gh}^{norm}$	$P_{gh}^{norm*}$
Carbonation depth	Carbonation depth (mm)	8	10	5	0.40	0.40
Chloride content	Chloride content (%)	0.08	0.08	0,04	0	0
Concrete cover (insufficient)	Affected area (%)	20	5	0	-3	-0.20
Corrosion (prestressing steel)	Affected area (%)	10	1	0	-9	-0.20
Corrosion (reinforcement steel)	Affected area (%)	15	1	0	-14	-0.20
Crack width (shrinkage)	Width (mm)	0.05	0.20	0	0.75	0.75
Crack width (longitudinal)	Width (mm)	0.50	0.20	0	-1.50	-0.20
Grouting deficiency	Percentage of strands	10	5	0	-1	-0.20
Pitted corrosion	Affected area (%)	15	5	0	-2	-0.20
Remaining service life	Number of years	15	28	48	-0.65	-0.20
Water penetrability	Affected area (%)	100	10	0	-9	-0.20

# APPLICATION IN THE STRIMONAS BRIDGE CASE STUDY

- Component quality performance scores, component relative weights, and final bridge quality performance score

**Table 4.** Quality performance of the Strimonas Bridge's components and system

Component	Notation	$Q_{compu}$	$W_{compu}$	$Q_{bridge}$
Abutment	$Q_{abut}$	0.112	0.171	
Pier	$Q_{pier}$	0.071	0.218	
Superstructure	$Q_{super}$	0.120	0.218	
Safety rail	$Q_{srail}$	0.650	0.101	<b>0.281</b>
Sidewalk	$Q_{side}$	0.627	0.087	
Pavement	$Q_{pave}$	0.897	0.087	
Drainage system	$Q_{drng}$	0.189	0.119	

# APPLICATION IN THE STRIMONAS BRIDGE CASE STUDY

- Spider graph depicting components' quality scores, relative weights, total scores (products of the individual quality scores and the relative weights), and percentile participation in the final bridge quality score

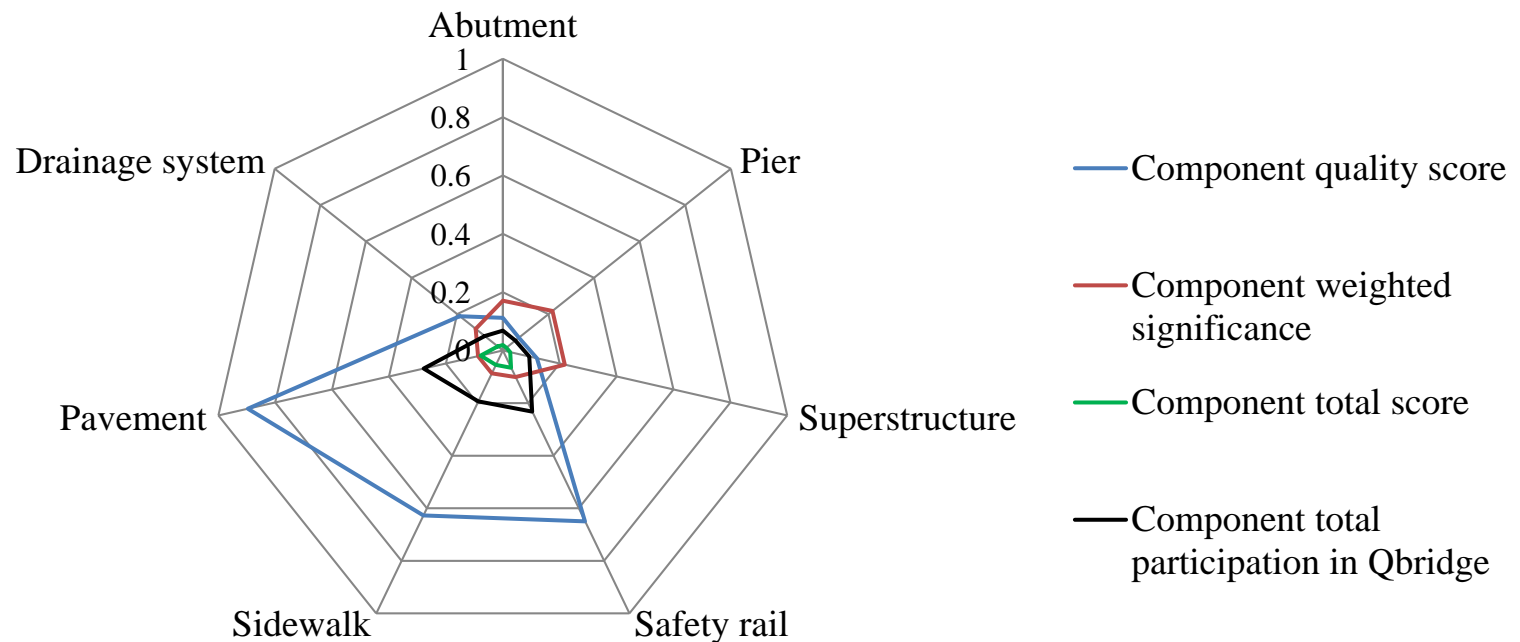

# APPLICATION IN THE STRIMONAS BRIDGE CASE STUDY

- Position of the final bridge quality performance score in the suggested methodology's rating scale

**Table 5.**  $Q_{bridge}$  and proposed quality bridge performance rating scale

$Q_{bridge}$	Rating	Characterization	Interval
	A+	Excellent (innovation)	$(Q_{bridge} > 1.00)$
	A	Good (best practice)	$(0.75 \leq Q_{bridge} \leq 1.00)$
	B	Adequate	$(0.50 \leq Q_{bridge} < 0.75)$
<b>0,281</b>	C	Acceptable (common practice)	$(0.25 \leq Q_{bridge} < 0.50)$
	D	Poor	$(0.00 \leq Q_{bridge} < 0.25)$
	E	Very poor	$(Q_{bridge} < 0.00)$

# APPLICATION IN THE STRIMONAS BRIDGE CASE STUDY

- $Q_{bridge} = 0.281$  translates into a “C” rating and marginally “Acceptable” quality performance
- Critical were the very low score and very high significance of the piers
- Strimonas Bridge’s sufficiency rating by E.O. S.A.:  $SR = 0.49$  (worst component condition rating is that of the piers ( $CR_{pier} = 0.333$ ))
- By qualitatively comparing  $Q_{bridge}$  with  $SR$ , and  $Q_{pier} = 0.071$  with  $CR_{pier}$ , it is clear that the presented methodology is much more conservative in its quality appraisal
- However, direct comparison may not be suitable, as the criteria, the scales, and the composition rules of the rating methods are generally not similar

# CONCLUSIONS

## General:

- The presented bridge quality appraisal methodology offers a clear step-by-step computational framework
- Deliverables: intermediate *PI*, *KPI* and component quality scores, and the final bridge quality score at the system level
- Highly customizable, allowing for the explicit weight assignment and *PIs*' identification and discretization
- Thus far, the only bridge quality appraisal methodology where *PIs*' measured values are correlated with their benchmark values of conventional and best achievable performance
- Solicited subjective expert input limited to the methodology's initial weighting procedures and only needed once per case study (except special or severe cases)



# CONCLUSIONS

Regarding the Strimonas Bridge case study:

- The methodology's final bridge quality score indicates a marginally acceptable, almost poor bridge condition
- In accordance to the official *SR* provided by Egnatia Odos S.A., also indicating a marginally deficient bridge ( $0.49 < 0.50$ )
- The present methodology's score is more conservative than *SR* and even the bridge's structural condition rating (*SCR*) applied by Egnatia Odos S.A., which is equal to the worst component *CR* (in the present case,  $CR_{pier}$ )
- More case studies, even featuring radically different bridge typologies, should be carried out, for the further calibration of the presented methodology

# REFERENCES

- Alonso, J.A.; Lamata, M.T. 2006. Consistency in the analytical hierarchy process: a new approach, *International Journal of Uncertainty, Fuzziness and Knowledge-based Systems* 14(4): 445-459. doi:10.1142/S0218488506004114.
- Amado, J. (2015). Road Asset Management System. Infraestruturas de Portugal IP.MOD.033.V01 report. 3 p.
- Barone, G.; Frangopol, D.M. 2014. Reliability, risk and lifetime distributions as performance indicators for life-cycle maintenance of deteriorating structures, *Reliability Engineering & System Safety*, 123: 21-37. doi:10.1016/j.ress.2013.09.013.
- Frangopol, D.M.; Dong, Y.; Sabatino, S. 2017. Bridge life-cycle performance and cost: analysis, prediction, optimisation and decision-making, *Structure and Infrastructure Engineering*: 1-19. doi:10.1080/15732479.2016.1267772.
- Frangopol, D. M.; Strauss, A.; Kim, S. 2008. Bridge reliability assessment based on monitoring, *Journal of Bridge Engineering*, 13(3): 258-270. doi:10.1061/(ASCE)1084-0702(2008)13:3(258).
- Ghosn, M.; Duenas-Osorio, L.; Frangopol, D.M.; McAllister, T.P.; Bocchini, P.; Manuel, L.; Ellingwood, B.R.; Arangio, S.; Bontempi, F.; Shah, M.; Akiyama, M.; Biondini, F.; Hernandez, S.; Tsiatas, G. 2016. Performance indicators for structural systems and infrastructure networks, *Journal of Structural Engineering* 142(9): F4016003-1 – F4016003-18. doi:10.1061/(ASCE)ST.1943-541X.0001542.
- Goepel, K.D. 2013. Implementing the analytic hierarchy process as a standard method for multi-criteria decision making in corporate enterprises – a new AHP Excel template with multiple inputs, in *Proc. of the International Symposium on the Analytic Hierarchy Process*, 23-26 June, 2013, Kuala Lumpur, Malaysia. 13: 1-10.
- Ishizaka, A.; Labib, A. 2011. Review of the main developments in the analytic hierarchy process, *Expert systems with Applications*, 38(11): 14336-14345. doi:10.1016/j.eswa.2011.04.143.
- Liang, Y.; Wu, D.; Huston, D.; Liu, G.; Li, Y.; Gao, C.; Ma, Z.J. 2017. Civil Infrastructure Serviceability Evaluation Based on Big Data, in Srinivasan, S. (Ed.). *Guide to Big Data Applications (Studies in Big Data)*, 295-325. Springer. 565 p.
- Mateus, R.; Bragança, L. 2011. Sustainability assessment and rating of buildings: Developing the methodology SBToolPT–H, *Building and Environment*, 46(10): 1962-1971. doi:10.1016/j.buildenv.2011.04.023.
- Padgett, J.E.; Tapia, C. 2013. Sustainability of Natural Hazard Risk Mitigation: Life Cycle Analysis of Environmental Indicators for Bridge Infrastructure, *Journal of Infrastructure Systems* 19(4): 395-408. doi:10.1061/(ASCE)IS.1943-555X.0000138.
- Panetsos, P. 2017. Work Group 4 – Sub Group B1: Detailed description of the existing data of the “Strimonas River Bridge”, Greece and the suggested PI and KPI to be used and their values. Research report for the COST Action TU1406 WG4 meeting, Institut Français des Sciences et Technologies des Transports, de l'Aménagement et des Réseaux (IFSTTAR) 2017, Marne-la-Vallée, France, 12 May, 2017. 104 p.
- Shao, Y.; Yuan, J.; Li, Q. 2017. Identification of the Residual Value Risk Factors for Road PPP Projects in China: Questionnaire Survey and Analysis, in Wu, Y.; Zheng, S.; Luo, J.; Wang, W.; Mo, Z.; Shan, L. (Eds.). *Proceedings of the 20th International Symposium on Advancement of Construction Management and Real Estate*, 379-389. Springer. 1335 p.
- Strauss, A., & Ivanković, A.M. (Eds.) (2016). WG1 Technical Report: Performance Indicators for Roadway Bridges of Cost Action TU1406. Braga: Boutik. 38 p.
- Xu, Z. 2000. On consistency of the weighted geometric mean complex judgement matrix in AHP, *European Journal of Operational Research*, 126(3): 683-687. doi:10.1016/S0377-2217(99)00082-X.
- Zhang, W; Wang, N. 2017. Bridge network maintenance prioritization under budget constraint, *Structural Safety* 67: 96-104. doi:10.1016/j.strusafe.2017.05.001.



**TU1406**  
COST ACTION

**THANK YOU FOR YOUR ATTENTION!**

[www.tu1406.eu](http://www.tu1406.eu)



# DEUSTO BRIDGE. STUDY AND DIAGNOSIS FOR REHABILITATION

Ignacio Piñero - Jesús Díez - Fran Barroso - Laura Pérez

*Fundación TECNALIA Research & Innovation*

*Sustainable Construction – Infrastructures*



# Table of contents

- 1. Introduction
- 2. History of the bridge
- 3. Bridge´s description
- 4. Works carried out
  - Topographic survey
  - Whole structure inspection
  - Steel and coating of paint tests
  - Vibrations measurements in deck
  - Works in movable span´s mechanisms
  - Study of the concrete structure´s durability
- 5. Conclusions

# 1.- INTRODUCTION

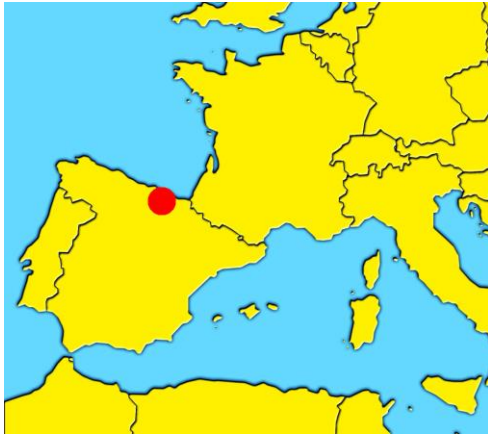

Deusto bridge is located in Bilbao (Basque Country), in the North of Spain. It was built in 1936 and joins the Bilbao centre with the Deusto district. It is next to the Deusto University, Iberdrola tower and Guggenheim museum.





## 2.- The HISTORY of the BRIDGE

Investigation to reconstruct the history of the bridge:

- Documentary search in the **archives** of the **Port Authority of Bilbao**, the **Provincial Council of Vizcaya** and the **Bilbao City Council**. Selection, recovery and reproduction of the documents for the project file.
- Search for information in **other sources**, such as **publications and companies** that have worked on the bridge, etc.
- **Analysis of recovered documentation**. Reconstruction of the history of the bridge, from its original project to the last performances on it. Identification of updated project bases (regulations, technical instructions, etc.).
- **Identification of the documents (drawings) that define the current theoretical state of the bridge**: foundation, structure, opening and closing mechanisms, electrical installation and affected services.



# The origin of the bridge

The development of the bridge project began in the mid-1920s of the last century.

In 1924, it was ratified the opinion of the municipal architect of Bilbao on the priority of a bridge linking Deusto with the Bilbao expansion district.

The idea of a movable span over the river matured on a previous trip from Bastida to the United States, where he visited the city of Chicago and its movable bridges.

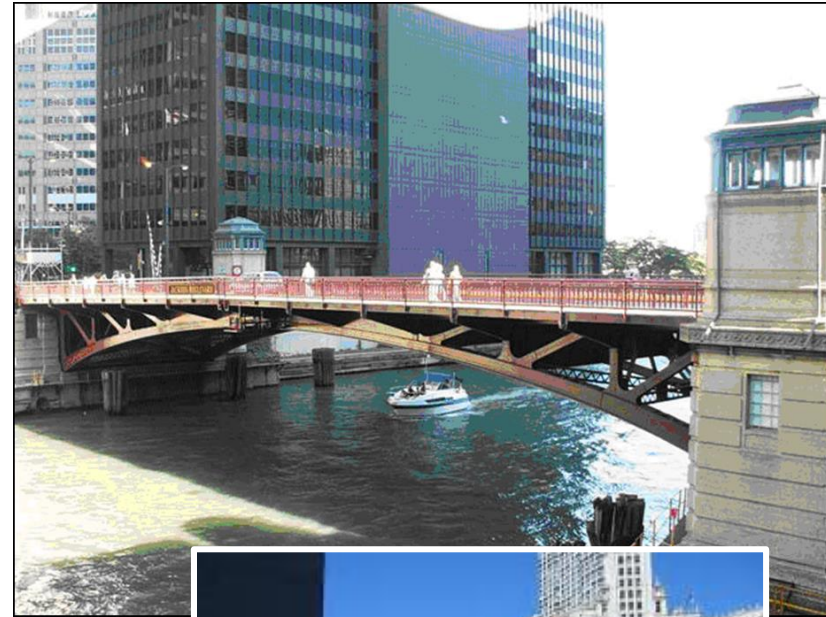



Photographs of the construction of the movable section.



Movable section at an advanced stage of construction.



Bridge after its explosion before the imminent arrival of Franco's troops.

### 3.- DESCRIPTION OF THE BRIDGE

- It consists of **27 spans**, with a **length of 522 m**.
- Span number 11: **movable section**
- Spans 1 to 10 and 12 to 20: **Reinforced concrete**
- Spans 21 to 27: **Steel structure**

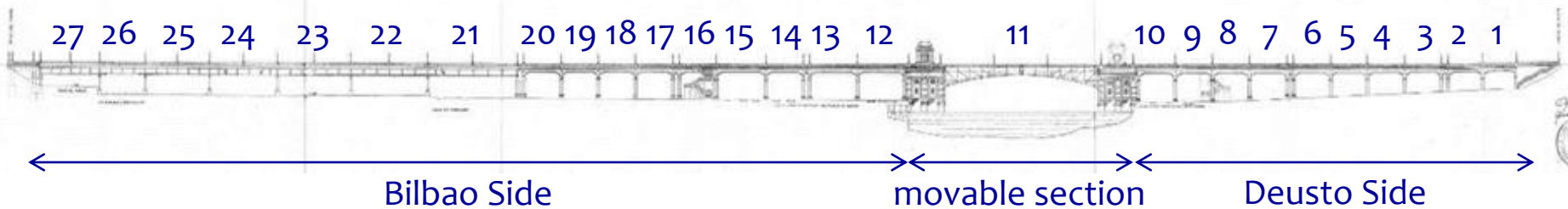

## Movable Section. Span number 11:

## Description of the Bridge

- **Crosses over the river.**
- It is a **bascule-rolling drawbridge**, with a nether counterweight.
- The two leaves of the bridge swing until reaching **an angle of 70° on the horizontal.**
- The **main beams** of each leaf are lattice beams, with **variable edge**, built with **riveted steel sections.**



## Description of the Bridge

## Movable Section. Span number 11:

It is made up of **two identical leaves** whose flown parts, in each one of them, has a length of 25 meters, being the total of the roadway of 32.2 m.



Each steel leaf is made up of **two main beams**, which are of lattice in the flown part and full web in the running surface and **counterweight**.

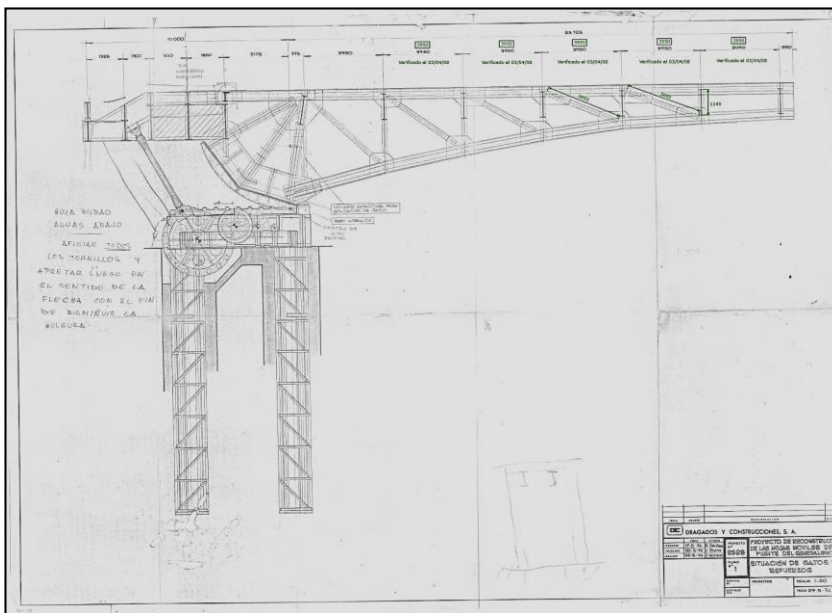

## Description of the Bridge

## Movable Section. Span number 11:

The support piers of the movable span are made of reinforced concrete and consist of a simple column-shaft with cutwater. They can be visited and the lifting machinery of the movable leaves can be seen.

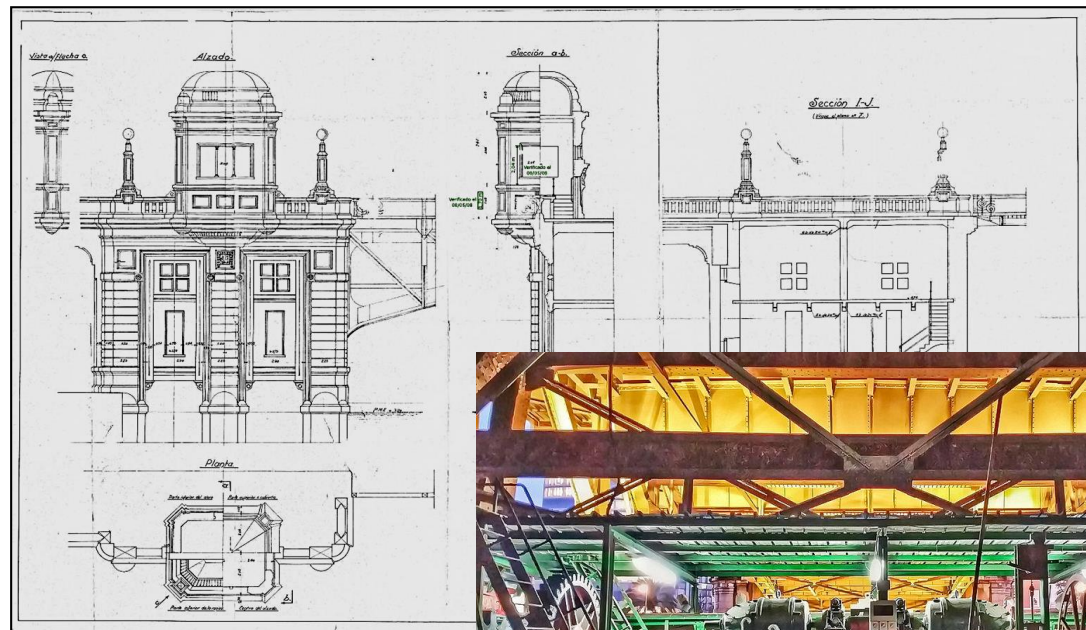

## Description of the Bridge

## Rest of spans:

- They are also called **access viaducts**.
- The type of decks are based on **piers / abutment**, with lights approximately between 11 and 25 m.
- The **platform width is 25 m** (15 m of road and 5 m for sidewalks).



## Span 1 to 10 and 12 to 20

## Description of the Bridge

- Reinforced concrete deck is made of rectangular beams, intermediate sleepers and supports, and slab floor.
- 18 open piers are built in reinforced concrete consisting of columns with a pier cap

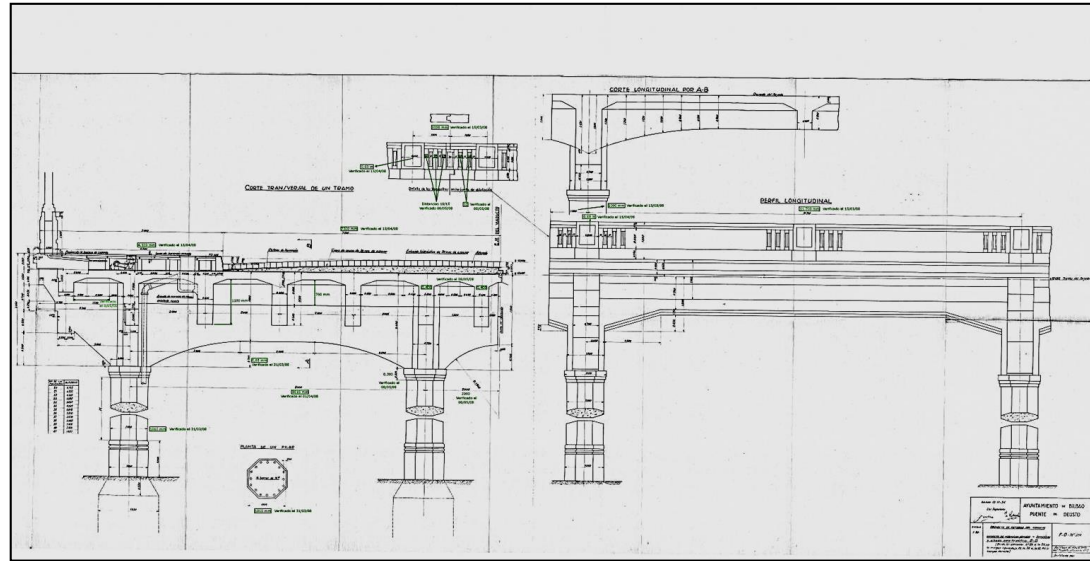



## Span 21 to 27

## Description of the Bridge

- Deck is made of beams and sleepers of riveted steel structure, and wrought is made of steel beam and reinforced concrete slab.
- The 6 open piers are built in riveted steel structure based on columns with a pier cap.

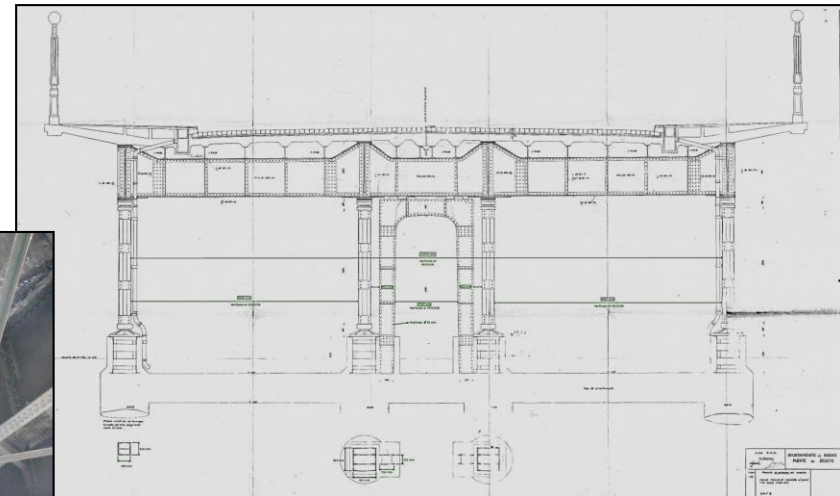
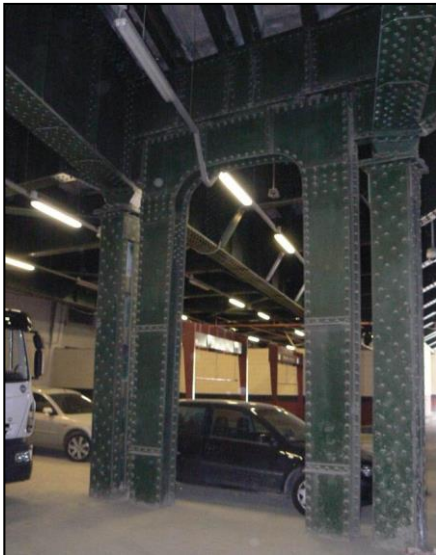

## 4. Works carried out

### Topographic survey

**Objective:** Define the geometry (planimetry and altimetry) of the bridge and of the racks of the elevation mechanism of the bridge.



- Topographic bases outside the bridge in UTM coordinate.
- Taquimetric survey of the bridge plant and the surrounding vials.
- Development of the longitudinal profile of the bridge.
- Geometric definition of some mechanisms of the movable section.

## 4. Works carried out

### Topographic survey

#### RESULT OF TOPOGRAPHICAL SURVEY:

It was certified that the analyzed documentation corresponded to the current configuration of the bridge.

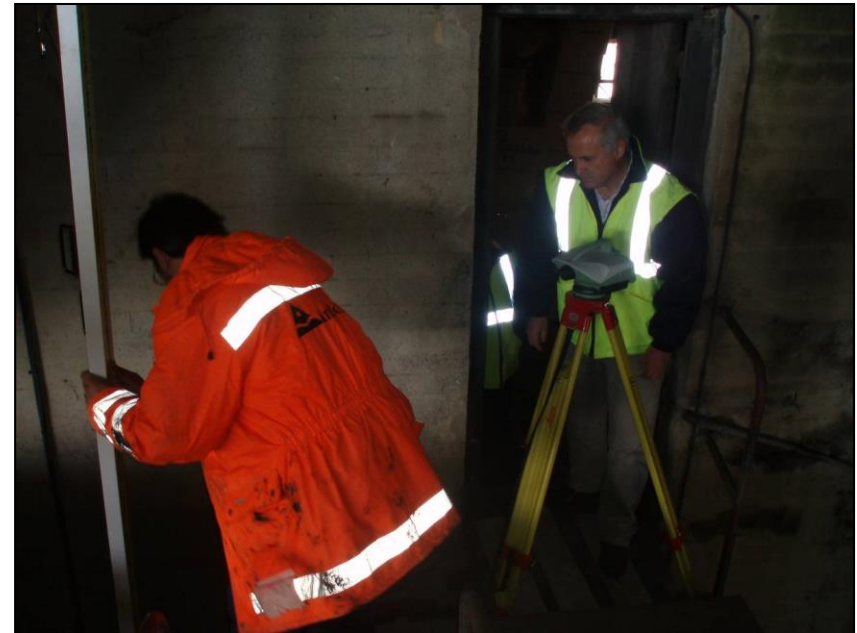

## 4. Works carried out

### Whole structure inspection

**Objective:** Detect possible damages or pathologies in the structure and its auxiliary elements.



- Inspection: beams, deck, piers, abutments and bearings. Inspection of the movable section.
- Inspection sheets: Sketch of the element + damages (situation and extension).
- Inspection of caskets to observe the state of the drainage system.

## 4. Works carried out

### Whole structure inspection



Visual inspection



Drainage system



Auxiliary resources

# 4. Works carried out

## Whole structure inspection

Inspection sheets of different elements of the bridge

Documento nº 80.0445.0 -IN-CT-08/01(v01)  
 ANEJO Nº1. REGISTRO DE LA INSPECCIÓN ESTRUCTURAL  
 Página 28 de 283

**labein**  
 tecnalia

**FICHA DE INSPECCIÓN**

Elemento: Pila 3 Fecha: 01/04/08

CROQUIS ESQUEMATICO DE UBICACION DE PATOLOGIAS

**CODIGO DE PATOLOGIAS Y REPRESENTACION GRAFICA**

PH	—	Fisura horizontal (longitud)	DPTO	■	Desprendimiento (superficie)
PV	+	Fisura vertical (longitud)	D	■	Desosneche (superficie)
P	—	Fisura inclinada (longitud)	PD	■	Peligro de desprendimiento de elementos sueltos
PI	—	Fisura en suelo (longitud)	AV	■	Armadura a la vista (longitud)
PT	—	Fisura en techo (longitud)	OK	■	Oxidación en perfiles metálicos
PC	—	Fisuración generalizada de revoco en piel de coque	COR	■	Corrosión en perfiles metálicos
COQ	—	Coque	ZR	■	Zona reparada
MH	—	Mancha de humedad (superficie)	Y	■	Bifreccencias
ABT	—	Abombamiento (superficie)	V	■	Vegetación / Vainín
AR	—	Arqueto	NI	—	No inspeccionado
	■	Instalaciones			

Observaciones:

Documento nº 80.0445.0 -IN-CT-08/01(v01)  
 ANEJO Nº1. REGISTRO DE LA INSPECCIÓN ESTRUCTURAL  
 Página 26 de 283

**labein**  
 tecnalia

**FICHA DE INSPECCIÓN**

Elemento: Vano 3. Tablero cara inferior Fecha: 01/04/08

CROQUIS ESQUEMATICO DE UBICACION DE PATOLOGIAS

**CODIGO DE PATOLOGIAS Y REPRESENTACION GRAFICA**

PH	—	Fisura horizontal (longitud)	DPTO	■	Desprendimiento (superficie)
PV	+	Fisura vertical (longitud)	D	■	Desosneche (superficie)
P	—	Fisura inclinada (longitud)	PD	■	Peligro de desprendimiento de elementos sueltos
PI	—	Fisura en suelo (longitud)	AV	■	Armadura a la vista (longitud)
PT	—	Fisura en techo (longitud)	OK	■	Oxidación en perfiles metálicos
PC	—	Fisuración generalizada de revoco en piel de coque	COR	■	Corrosión en perfiles metálicos
COQ	—	Coque	ZR	■	Zona reparada
MH	—	Mancha de humedad (superficie)	Y	■	Bifreccencias
ABT	—	Abombamiento (superficie)	V	■	Vegetación / Vainín
AR	—	Arqueto	NI	—	No inspeccionado
	■	Instalaciones			

Observaciones:

Documento nº 80.0445.0 -IN-CT-08/01(v01)  
 ANEJO Nº1. REGISTRO DE LA INSPECCIÓN ESTRUCTURAL  
 Página 112 de 283

**labein**  
 tecnalia

**FICHA DE INSPECCIÓN**

Elemento: Pila 11. Laterales Fecha: 15/04/08

CROQUIS ESQUEMATICO DE UBICACION DE PATOLOGIAS

**CODIGO DE PATOLOGIAS Y REPRESENTACION GRAFICA**

PH	—	Fisura horizontal (longitud)	DPTO	■	Desprendimiento (superficie)
PV	+	Fisura vertical (longitud)	D	■	Desosneche (superficie)
P	—	Fisura inclinada (longitud)	PD	■	Peligro de desprendimiento de elementos sueltos
PI	—	Fisura en suelo (longitud)	AV	■	Armadura a la vista (longitud)
PT	—	Fisura en techo (longitud)	OK	■	Oxidación en perfiles metálicos
PC	—	Fisuración generalizada de revoco en piel de coque	COR	■	Corrosión en perfiles metálicos
COQ	—	Coque	ZR	■	Zona reparada
MH	—	Mancha de humedad (superficie)	Y	■	Bifreccencias
ABT	—	Abombamiento (superficie)	V	■	Vegetación / Vainín
AR	—	Arqueto	NI	—	No inspeccionado
	■	Instalaciones			

Observaciones:

# 4. Works carried out

## Whole structure inspection

Photographic report



## 4. Works carried out

### Whole structure inspection

#### RESULT OF THE INSPECTION:

The status of the access viaducts was considered "good", requiring small actions of cleaning, maintenance and replacement of the drainage system.

Critical pathologies were found in the movable section. Some of them, required urgent action to avoid a degradation of the security level of the bridge.

It appeared that in the previous 10-15 years the maintenance of the movable span had been tight.

Most of the pathologies found had their origin in the lack, or in the total ineffectiveness, of the drainage system.



## 4. Works carried out

### Steel and coating of paint tests

**Objective:** Determine the state of the coating paint and the possible loss of section of the structural steel elements.



- Span 11 (movable section) and spans 21 to 27: Steel structure.
- Tests to determine the remaining thickness of steel and paint thickness (before and during repair).
- Paint adhesion tests (before and during repair).
- Visual inspection of the coating (during repair).

## 4. Works carried out

### Steel and coating of paint tests



## 4. Works carried out

### Steel and coating of paint tests

#### RESULT OF STEEL AND PAINT TESTING:

The tests gave satisfactory results.

In the visual inspection carried out during the repair, aesthetic defects were observed: detachments, brush marks and dirt in the paint layer.

## 4. Works carried out

### Vibrations measurements in deck

**Objective:** Quantify the vibrations generated in the movable section as a result of vehicle traffic.



- Measurements of vibrations in the deck of the movable section, close to the lateral joints and the central joint.
- Spectral data of continuous vibration, using triaxial technology.

# 4. Works carried out

## Vibrations measurements in deck

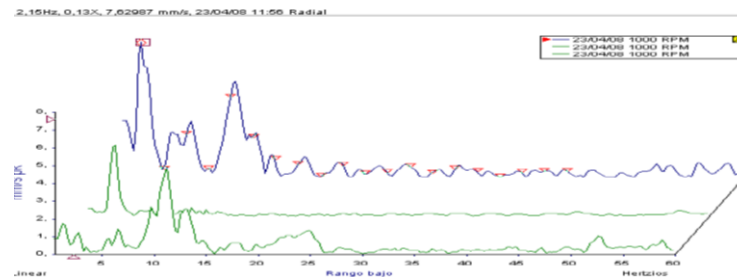
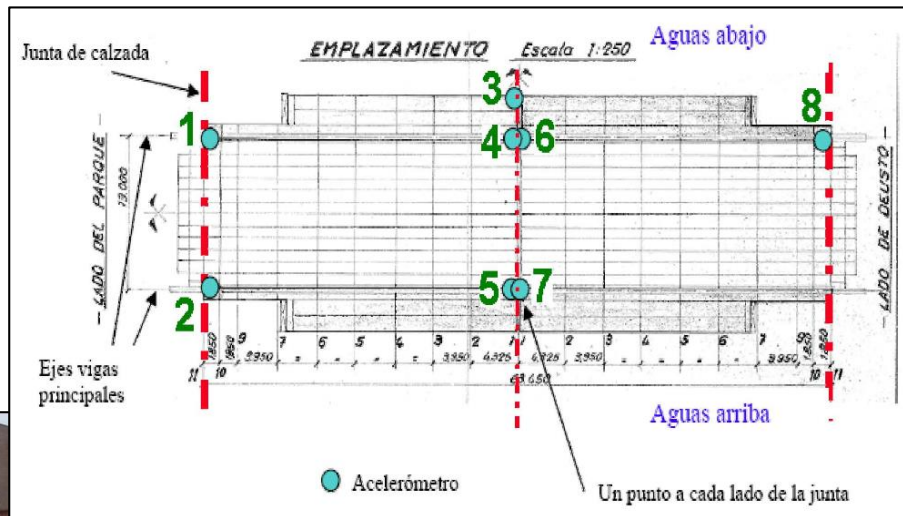

## 4. Works carried out

### Vibrations measurements in deck

#### RESULT OF VIBRATION MEASURES:

There was a high level of vibration in the movable compartment.

## 4. Works carried out

### Study of the concrete structure's durability

**Objective:** Determine the condition of the concrete and the reinforcements of the access viaducts.



- ✓ Realization of trial pits in the concrete, in areas where cracking existed.
- ✓ Tests for the determination of carbonation depth.
- ✓ Tests for the determination of the chloride profile.

## 4. Works carried out

### Study of the concrete structure's durability





# 4. Works carried out

## Study of the concrete structure's durability

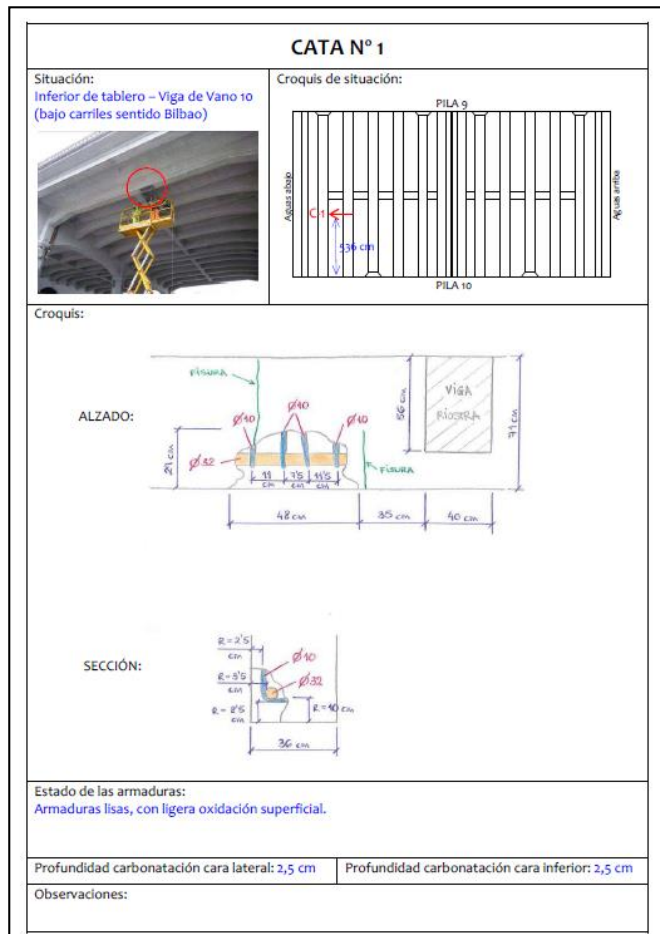

## 4. Works carried out

### Study of the concrete structure's durability

#### RESULT OF THE CONCRETE DURABILITY STUDY:

The armor of the beams of the deck was in good condition, with a slight superficial corrosion.

The cracks in the beams were superficial and coincided with the position of the brackets.

In two of the tests the carbonation depth was greater than the coating of the reinforcements, resulting in corrosion in those areas.

The chloride content was, in all the samples analyzed, lower than the maximum admissible value.

# Conclusions

1. The inspection carried out on the structure made it possible to determine the cleaning and maintenance tasks necessary for the correct conservation of the bridge, as well as the need to replace the drainage and water collection system at several points, in order to reduce the pathologies observed as a consequence of its deficient state.
2. The "critical" pathologies observed in the movable segment served to define the action that should be carried out urgently, in order to avoid a degradation of the safety level of the bridge.

# Conclusions

3. The withheld parts the deteriorated beams and plates were repaired and repaired in the area of counterweights and crankshaft and bolts and bolt caps with new design and material were replaced. All this has contributed to increase the structural safety of the bridge and to significantly reduce the vibrations that occurred on the deck.
4. The results of the tests carried out on the opening and closing mechanisms of the bridge confirmed the need for its repair and commissioning before proceeding to open it again.
5. From the tastings and tests carried out on the concrete elements, it was concluded that their condition was good, requiring only the repair of some specific areas.

# Acknowledgments



IDOM Consulting and Engineering



Bilbao City  
Council

**Bilbao**

UDALA  
AYUNTAMIENTO

**IT781-13 Researching Group:**  
Integral sustainability in building systems and their materials





infra  
estructuras

tecnalia

Iñaki Piñero Santiago  
[ignacio.pinero@tecnalia.com](mailto:ignacio.pinero@tecnalia.com)  
+34 667 178 898



# CHALLENGES OF BRIDGE MANAGEMENT IN ESTONIA

**Sander Sein** – Estonian Road Administration/Tallinn University of Technology,  
Estonia

# Outlines

- Overview of bridge network
- Common typologies and damages
- Bridge assessment
- Decision-making
- COST TU1406



# Estonia

- Oldest known endonym of the Estonians is „country people“ or „people of the soil“. (*Ariste, P. 1956*)
- We belong to ethnic group of Balts or Baltic people (with Latvians and Lithuanians)
- Independence declared in 1918
- Independence restored in 1991
- Area is 45,336 km<sup>2</sup>
- Population is approx. 1,35 million.



# Road Network of Estonia

- Total length of Estonian road Network 58 936 km
  - Private and forest roads 18 398 km
  - Local roads 23 944 km
  - National roads 16 594 km (+ 87,6 km of ice roads)
    - E-roads 1 294 km

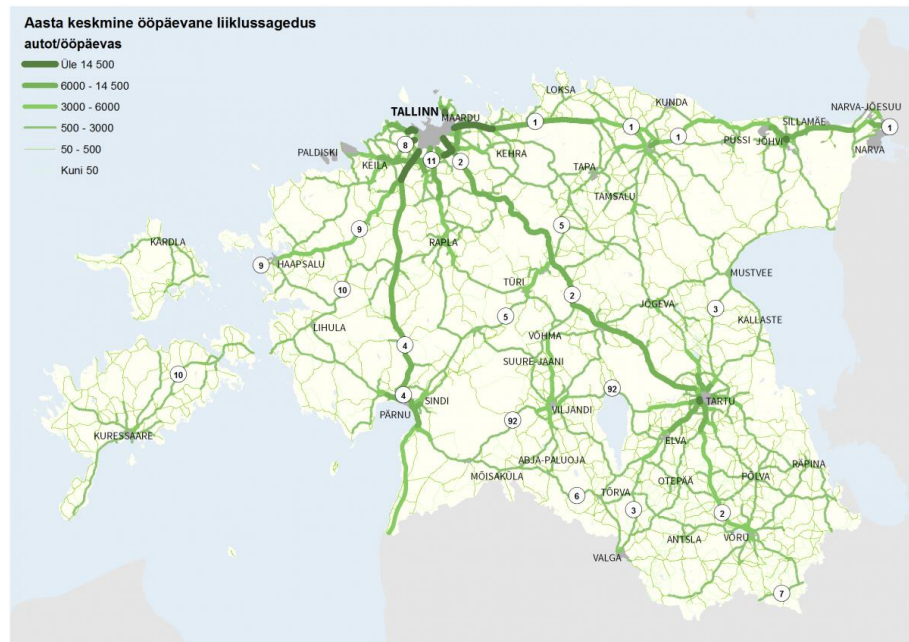

# Bridge network of Estonia

- Total number of bridges is approximately 3300
  - Estonian Road Administration 995
  - Estonian Railways LTD. \*information not shared
  - Local authorities approximately 600 (664 in 2008)
  - Forest roads ?
  - Private roads ?
  - Estonian Defense Forces \*information not shared

**Challenge 1: Know the owners and quantity of bridges in Estonia.**

# Estonian Road Administration

- Operating within the administrative area of the Ministry of Economic Affairs and Communications
- Government agency with a controlling function
- Main functions:
  - Road management and creating conditions for safe traffic on national roads
  - Increasing road safety and reducing the harmful environmental impact of vehicles
  - Keeping the national register of roads, the traffic registry, the national public transport register and the fixed automatic speed measuring system

# Estonian Road Administration

The main functions of ERA are split between activities concerning **construction, maintenance, traffic and road registers**, which are managed by Deputy Director Generals and Heads of departments. The ERA's main functions are supplemented by support activities.

- Approximately 500 employees and officials
- 6 people, who are dealing with bridges
- 1 person, who is dealing with bridge assessment and management

**Challenge 2: Manage 995 bridges with 1 (6) people**

# Bridges of Estonian Road Administration

## Age of structures

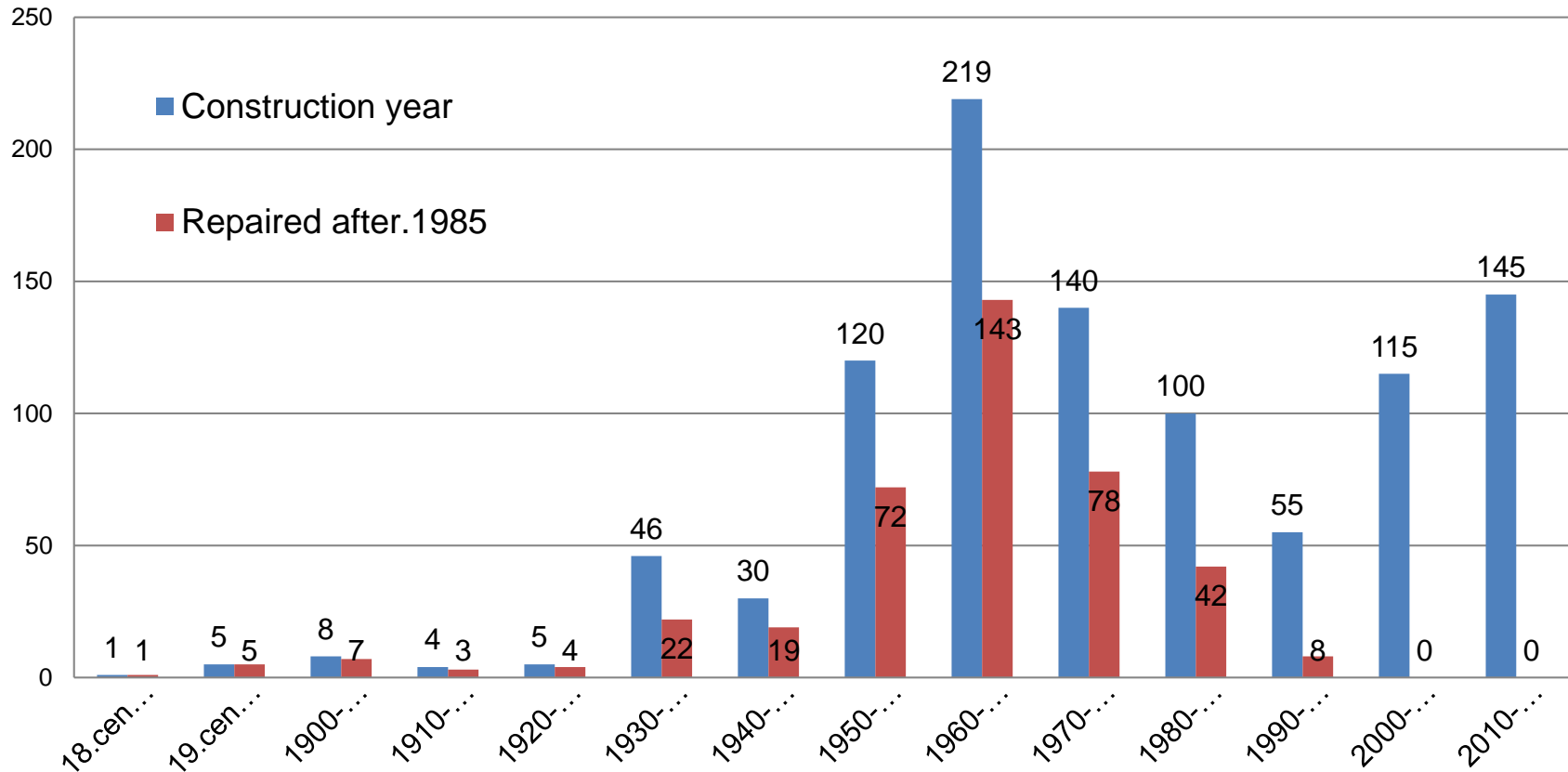

# Bridges of Estonian Road Administration

## Typology

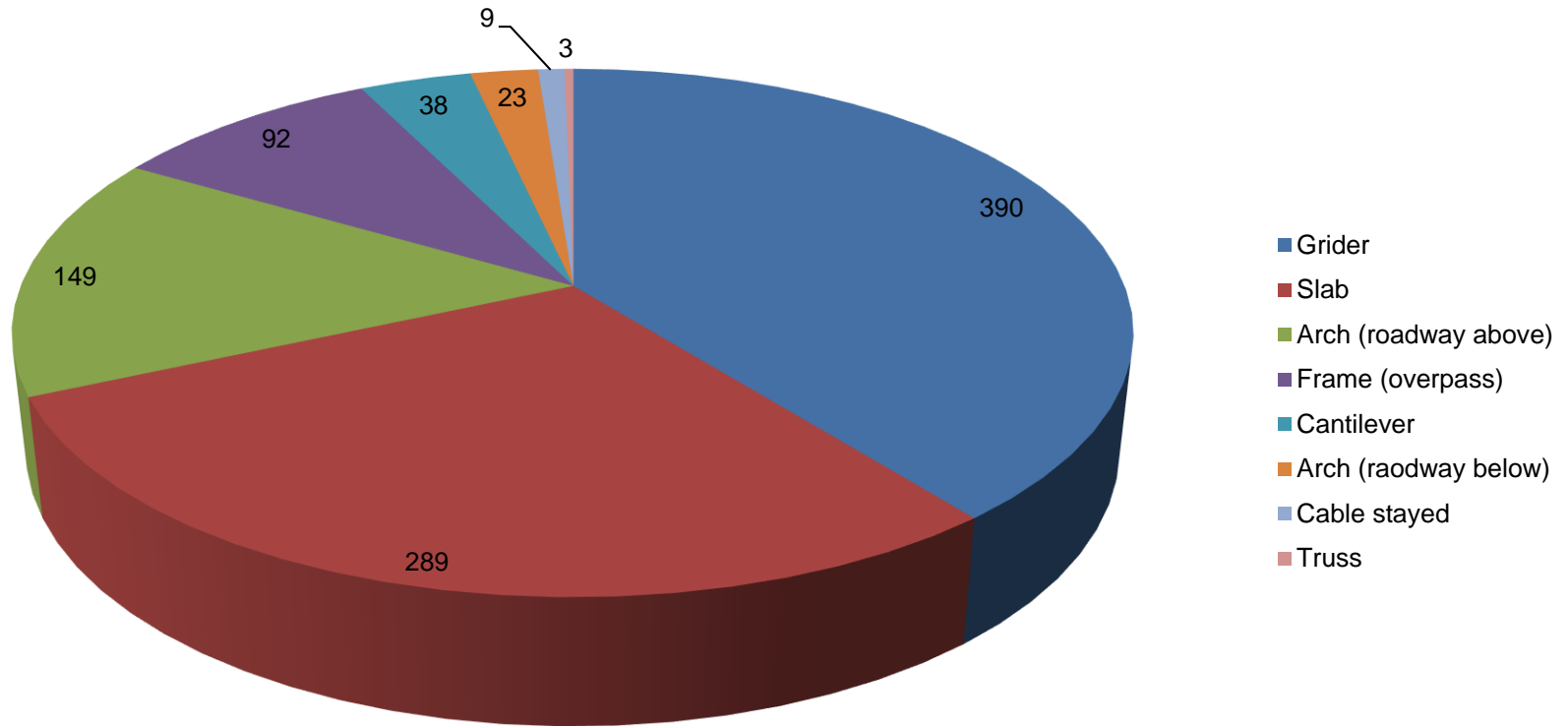

# Bridges of Estonian Road Administration

## Average bridge of ERA

- Length: 14 m
- One span
- Built in 1975
- Not repaired
- Material: reinforced precast concrete
- Main girder typology: simply supported beam



# Average bridge of ERA



# Average bridge of ERA



# Main typologies background

- Majority of the bridges are constructed during Soviet era (61%)
- Most of the structures are constructed based on design catalogue products
- Design catalogues are produced from 1945 till nowadays
- Most common catalogue:

СССР  
МИНИСТЕРСТВО ТРАНСПОРТНОГО СТРОИТЕЛЬСТВА Инв. № 8015 Т/М  
ГЛАВТРАНСПРОЕКТ  
„СОЮЗДОРПРОЕКТ“

**ТИПОВЫЕ ПРОЕКТЫ**  
*сооружений на автомобильных дорогах*

ВЫПУСК 56 - ДОПОЛНЕНИЯ

ВАРИАНТ КОНСТРУКЦИЙ ЖЕЛЕЗОБЕТОННЫХ СБОРНЫХ ПРОЛЕТНЫХ СТРОЕНИЙ  
БЕЗ ДИАФРАГМ С КАРКАСНОЙ АРМАТУРОЙ ПЕРИОДИЧЕСКОГО ПРОФИЛЯ

ПРОЛЕТЫ В СВЕТУ: 7.5; 10.0; 12.5 И 15.0 М  
НАГРУЗКИ: Н-13 И НГ-60; Н-18 И НК-80  
ГАБАРИТЫ: Г-6; Г-7 И Г-8 С ШИРИНОЙ ПРОТЯЗОВ 0.75 И 1.50 М

ДИРЕКТОР Г.В. „СОЮЗДОРПРОЕКТ“	<i>М.В. Шубин</i>	ЗВОНКОВ И.Ф.
ГЛАВНЫЙ ИНЖЕНЕР Г.В. „СОЮЗДОРПРОЕКТ“	<i>С.И. Сидор</i>	МОРОЗ И.П.
НАЧАЛЬНИК ОТДЕЛА ИСКУССТВЕННЫХ СООРУЖЕНИЙ	<i>В.С. Воронин</i>	ЧАРЫЙСКИЙ А.В.
ГЛАВНЫЙ ИНЖЕНЕР ПРОЕКТА	<i>В.И. Шубин</i>	ГАЛЬПЕРИН Р.М.

УТВЕРЖДЕН МИНИСТРОМ СССР  
4 ИЮНЯ 1962 Г.  
РАСПОРЯЖЕНИЕМ № Ф-832

МОСКВА · 1962 · ГОД

ИНВ. 147/2-2

# Design Project of average bridge of ERA

Инв. № 8015-Т4

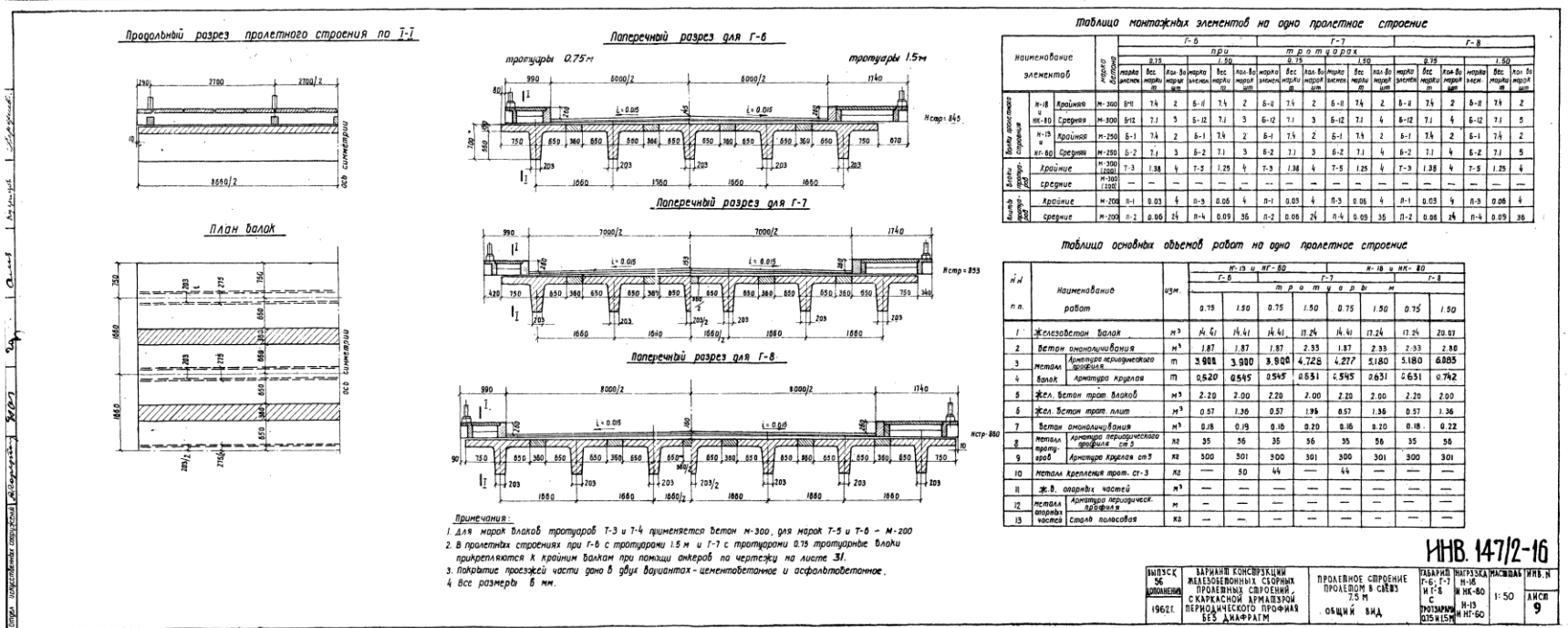

ИИВ. 147/2-16

ВЫПУСК № 19621	ВАРИАНТ КОНСТРУКЦИОННО-ТЕХНИЧЕСКОГО ПРОЕКТА ПРОЕКТНО-СМОНТАЖНО-ОПЕРАТИВНО-ПРОИЗВОДСТВЕННОГО ПРОЕКТА СКАТКАСКОЙ АРМАТУРЫ ПЕРИОДИЧЕСКОГО ПРОФИЛЯ БЕЗ ДИАМЕТРА	ПРОЕКТНО-СМОНТАЖНО-ОПЕРАТИВНО-ПРОИЗВОДСТВЕННОЕ ПРОЕКТИРОВАНИЕ В СЯЗЫ С ИНЫМИ ВИДАМИ	РАБОТА ВЫПОЛНЕНА ПО К-6-13 И К-6-14	РАБОТА ВЫПОЛНЕНА ПО К-6-13 И К-6-14	ИИВ. 147/2-16	1:50	АКСС 9
----------------	---	---	-------------------------------------	-------------------------------------	---------------	------	--------

# Other typologies

- Precast slab bridges



# Other typologies

- Cantilever



# Other typologies



# Examples from local roads



## Challenge 3: Unknown condition of local bridges



# Main damages

- Leakage of deformation joints
- Corrosion related to reinforcement (due to thin concrete cover)
- Corrosion related to equipment made of steel
- Debris
- Erosion
- Freeze-thaw
- Efflorescence – (symptom)

## Challenge 4: How to keep bridges safe with all the damages?

*ERAs Annual budget for interventions and maintenance actions is 5-7 million*

# Bridge assessment in ERA

- ...-2005 bridge cards were used
- 2003-2005 development of unified inspection system based on bridge cards/AASHTO and program Pontis 4.3.1
- 2005-2013 unified inspections by consultant company
- 2014 Pontis Update request, which were denied

Gives you 30 days  
free trial



**FOREVER**

www.forever.com

- 2015-... inspections continued, but program is MS Excel based

**Challenge 5: Make decisions without the help of professional program**

# Bridge assessment in ERA

- Data inventory - National Road Databank
- Inspections
  - Maintenance inspections every year
  - Main inspection once in every 4 years
  - No special or underwater inspections
- Planning –MS Excel program and Google applications
- Intervention types – repair, reconstruction or demolition
- Maintenance actions – cleaning and small repair

# Bridge assessment in ERA

## Evaluation of element condition (CI)

- Every element is evaluated, unit based
- 4 states (1 very good – 4 very poor) *without time frame*
- Urgent damages *with time frame*

Element	Area	CI 1	CI 2	CI 3	CI 4	Urgent
500	6	0	6	0	0	
460	171	0	171	0	0	
800	29	0	14	15	0	B
839	10	10	0	0	0	
836	4	4	0	0	0	
110	254	230	18	6	0	
200	20	20	0	0	0	
819	130	129	1	0	0	

# Bridge assessment in ERA

- **BCI (Bridge Condition Index) 0-100%**
  - Current element value/Total element value=CI
  - Different elements have different weight factors
  - Overall BCI is calculated based on weighted average

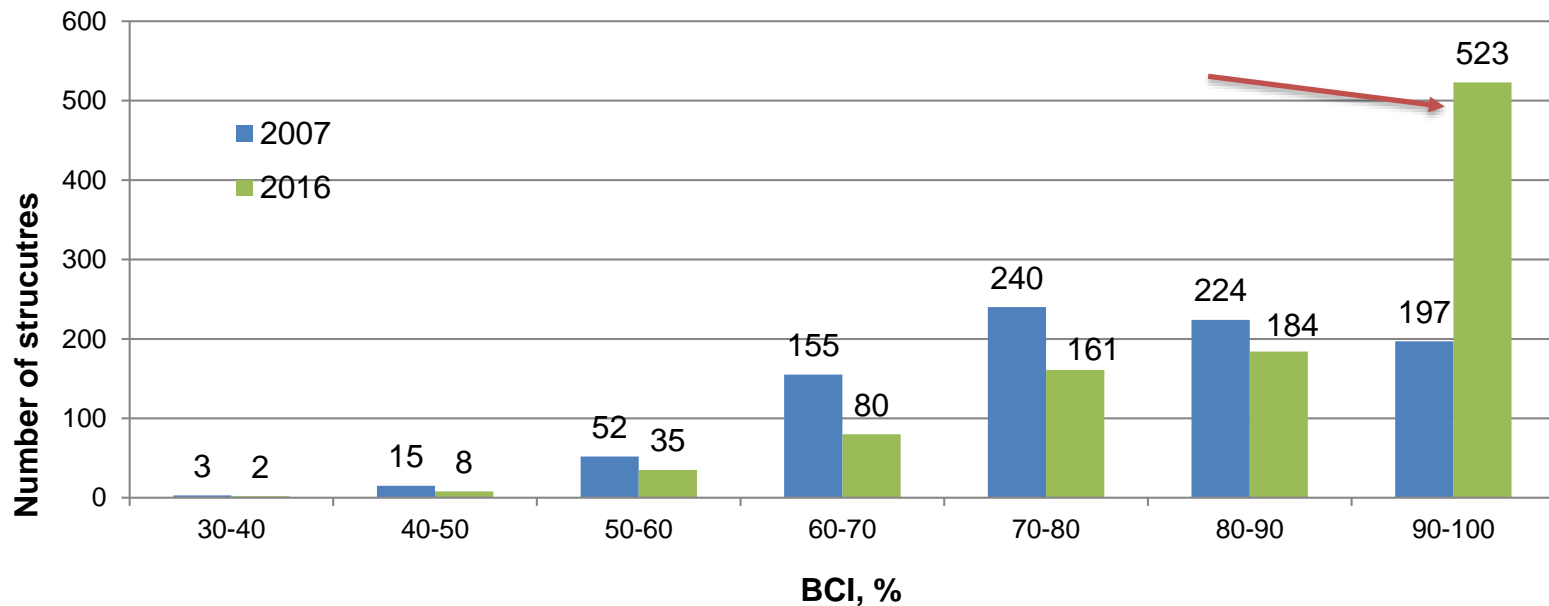

# Bridge assessment in ERA

- BCI is a static value
- To validate the initial decay rate 0,6% - values of different evaluations are compared.

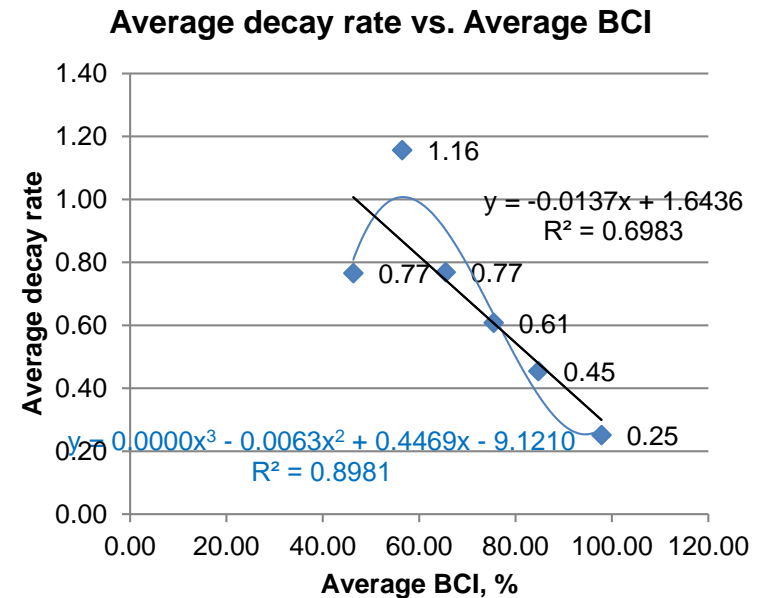
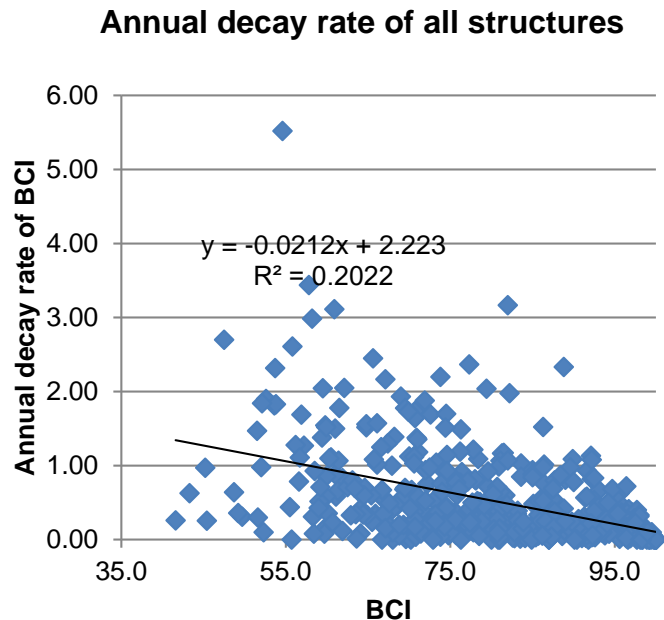

# Bridge assessment in ERA

- Function from the relation  $y = -0.0137x + 1.6436$

Average BCI curve

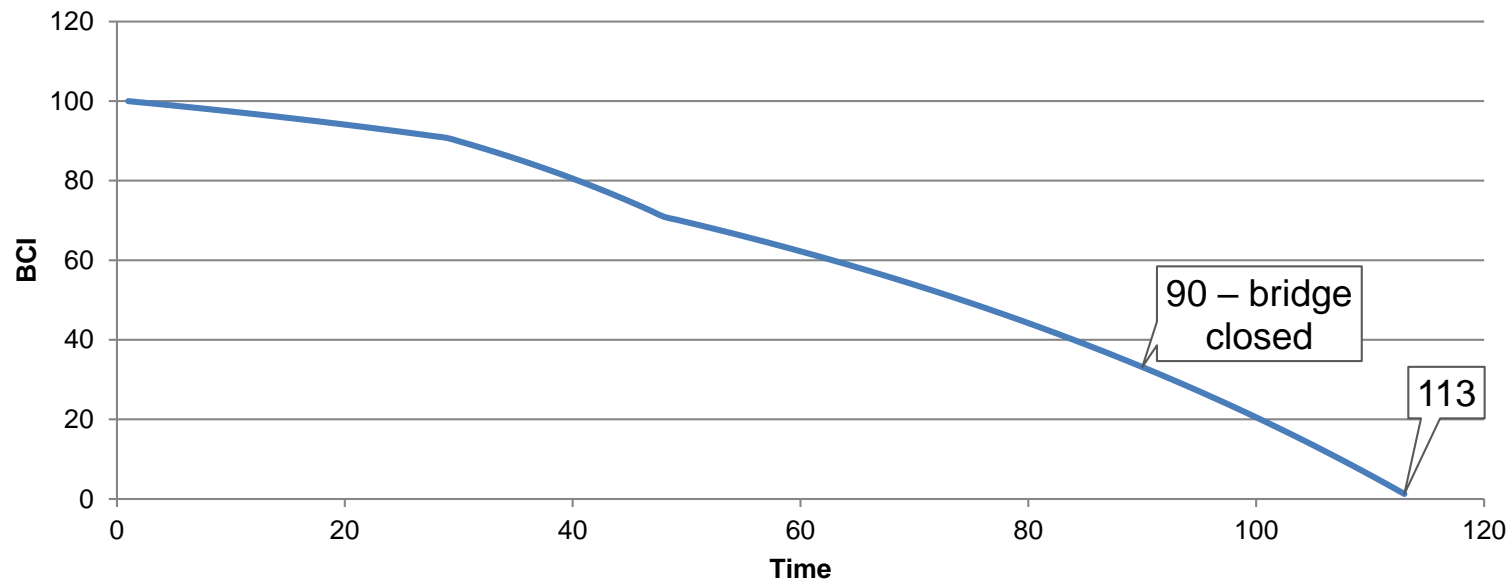

# Bridge assessment in ERA

- Bridge Condition Index is easily understandable indicator for decision-making, but it doesn't give any information regarding to reliability or safety.
- Additional assessment is done during re-design phase – NDT
- Modal testing and validation procedure of structural resistance assessment is in preparation

**Challenge 6: How to translate assesment values into more useful outcome?**



# Decision-making

- **Ranking of bridges** – making decisions which bridge needs intervention based on same background

Idea is to keep it as simple as possible, but still being systematic and rational

- Bridges are ranked using same background
- Every bridge is included
- Gives initial indicator

# Decision-making

- Background of ranking system
  - BCI
  - Traffic intensity, percentage of heavy traffic
  - Width of a bridge (compared to road)
  - Time from last intervention

No	Construction year	Last intervention	Road width on bridge	Road width	AADT	Heavy traffic	BCI	Rank	Repair	Overall repair	Reconstruction
52	1975	0	8	9	10570	21	59	1	40634.62	97416.79	186629.2
618	1957	0	7	8	2582	7	43	2	22586.46	27287.62	54770.5
71	1975	0	9	9.2	8120	5	61	3	78025.88	123906.5	235065.7
66	1975	0	8	9.2	9684	25	74	4	53794.51	108122.7	155302.6
54	1974	0	8	9	8623	28	75	5	525385.9	692049.5	811837

# Decision-making

- Further decisions are based on (KPIs?)
  - Safety
  - Material properties (Reliability)
  - Politics
  - Economics

**Challenge 7: Further decision-making must support strategic goals**

# Benefits of COST TU1406

- WG1 Performance indicators (PI)
  - What kind of PIs are available (385)
  - What kind of PIs are relevant
  - How PIs are classified
  - Basis of Key Performance Indicators
- WG2 Performance goals (PGs)
  - From PIs to KPIs
  - Description of PGs and LCC
- WG3 Quality control plan
  - Framework of how to assess

# Assesment procedure of COST TU1406

Element level

- Visual inspection of element = CI

Structure level

- $CI * \text{Weigh factor of element} = BCI$

Network level

- $BCI + \text{Traffic} + \text{Age} + \text{Width} = \text{Ranking}$

# Assessment procedure of COST TU1406

- Spider of ERA

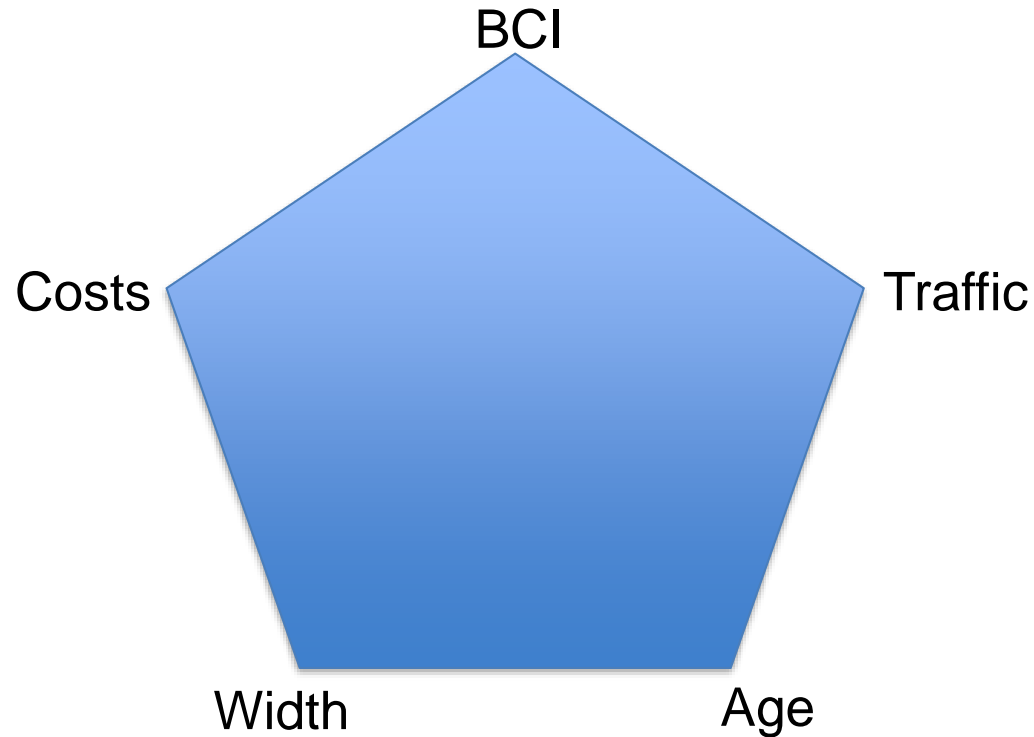

# Assesment procedure of COST TU1406

What is missing? PERFORMANCE GOALS!

- Strategic goals and tactical strategies are missing
  - Actually there are goals, but without relevant KPIs/PGs.
- WG2 Report is helpful if goals are missing (solves Challenges 7, 8)

## Challenge 8: Tactical goals with PGs(KPIs)

# Assessment procedure of COST TU1406

- WG 3 QC plan – after getting a grasp of it, will solve challenges 3-6

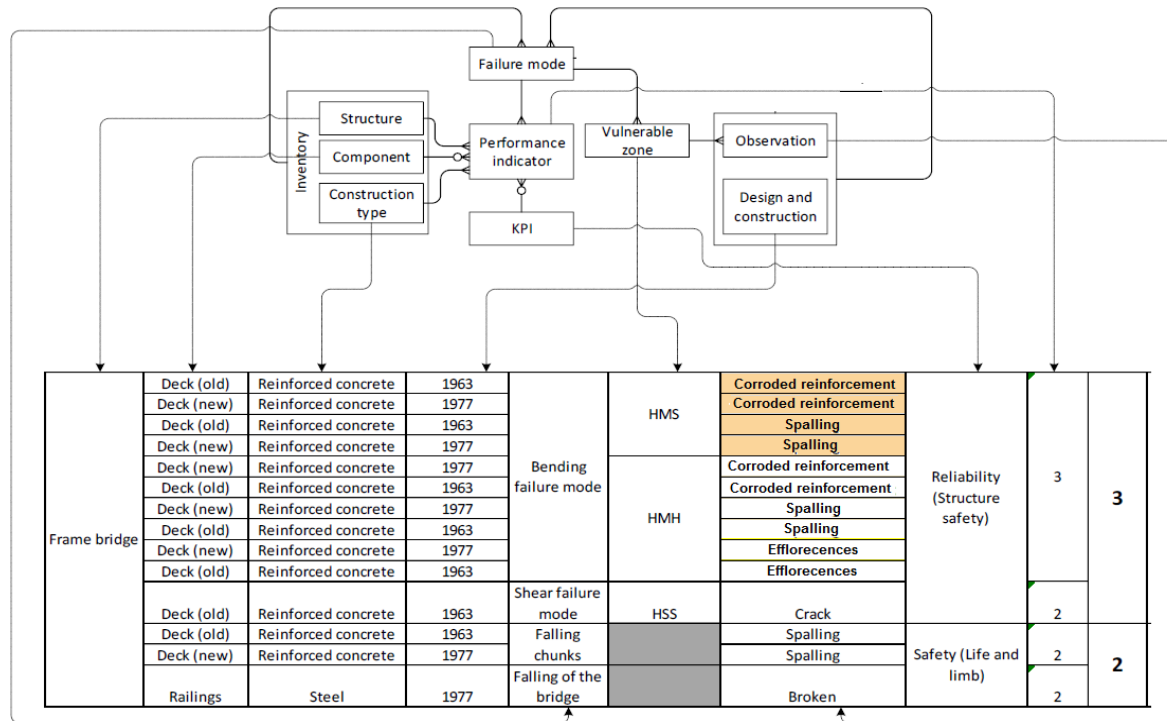

Hajdin, 2017



# Conclusion

- **Challenge 1: Know the owners and quantity of bridges in Estonia**
- **Challenge 2: Manage 995 bridges with 1 (6) people**
- **Challenge 3: Unknown condition of local bridges**
- **Challenge 4: How to keep bridges safe with all the damages?**
- **Challenge 5: Make decisions without the help of professional program**
- **Challenge 6: How to translate assesment values into more useful outcome?**
- **Challenge 7: Further decision-making must support strategic goals**
- **Challenge 8: Tactical goals with PGs**
- **Challenge 9: Study the framework**



**TU1406**  
COST ACTION

**THANK YOU FOR YOUR ATTENTION!**



# **RUSSIAN BMS – STATE OF THE ART AND FURTHER DEVELOPMENT**

**Anton Syrkov** - PLC "Transmost", St. Petersburg, Russian Federation

**Yury Rybalov** – CJSC "SibNIT", Novosibirsk, Russian Federation



# RUSSIAN ROAD NETWORK

European part  $\approx 25\%$

Asian part  $\approx 75\%$

Russian Federation

Масштаб 1:27 000 000

# Euro-Asian Economic Community challenges for the national road bridge stocks



- Upgrading of national Codes, techniques, guidelines and so on documents to make them compatible for EurAsEC members;
- Adaptation the old Codes to new structures, materials, numeric calculations and techniques;
- New Codes development, the Regulatory Framework enhancing till the world's advanced standards;
- Improving of safety, reliability and efficiency of design solutions;
- Improving the quality of bridge construction works;
- Reducing of bridge failures number and consequences;
- Bridge management systems (BMS) enhancing;
- Bridge stock life cycle costs (LCC) reduction.

# Some features of the Russian bridge stock

- About 70% of capital bridges were built in the period 1970 – 1990;
- Average lifetime of a capital bridge superstructure on public roads in Russia was estimated as 43 years for the current period;



- A proportion of steel, composite, reinforced & prestressed concrete superstructures designed by model projects achieves 80% both in Russia and in other EurAsEC countries, which simplifies the compatibility and functioning of Codes, BMS, and so on.

# But the unique bridge park also increases

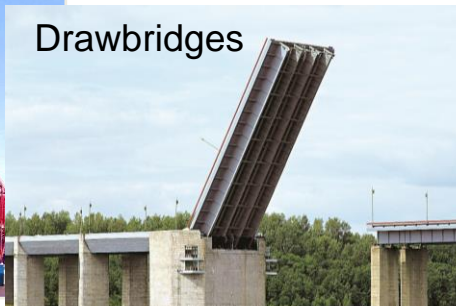

# The need was to improve Russian BMS

- The old database "MONSTR" did not have the required speed, analytical capabilities, had an outdated interface. It hadn't capabilities to treat properly new types of bridge structures.
- It have been registered increasing of bridge failures number in the beginning of XX century.
- Regular bridge inspections in Russia showed that the actual average service life for reinforced concrete superstructures constructed in 1960 -1970 years is 43 years. Even in accordance with the National Program for 2010 - 2015, the average lifetime of bridge superstructures in Russia, replaced by 2010, was estimated only as 48 years.
- As a result, the budget deficit and the need to save money for the development of new infrastructure contributed to the promotion of the State Order for the creation of a fundamentally new BMS.



# Growing of lifetime saves the life cycle costs

Well known, that the greatest opportunities to reduce the bridge life cycle costs gives increasing of their lifetime at moderate maintenance costs.

There are many cases of successful work of reinforced concrete bridge structures in Saint-Petersburg, Russia, during more than 60 and even 100 years:



# Examples of long lifetime of steel bridges (long service life = quality + regular cure)

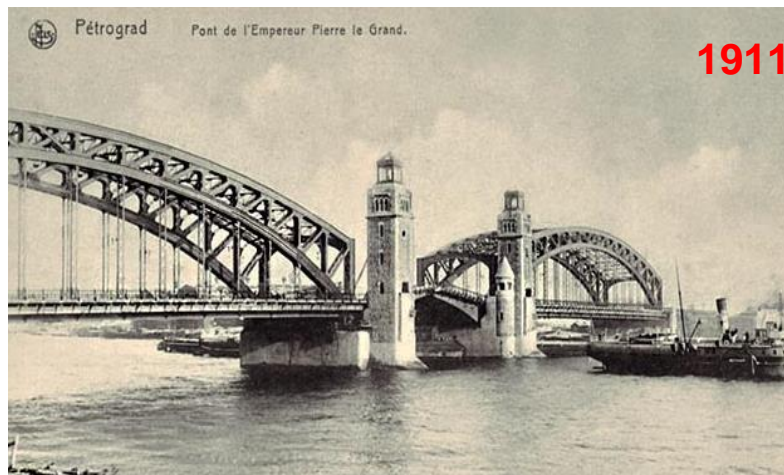

# BMS cycle (routine maintenance not shown)



# AIS ISSO-N is a core part of the Russian BMS

The modern Analytical Information System AIS ISSO-N is intended for information managing support of the road bridges, pipes, retaining walls and other artificial road structures with automating solution of the following main tasks:

- Registration and operational access to structural and performance data;
- Treatment of data, including search, sorting, analysis etc;
- Assessment and prediction of the structures technical condition;
- Determination of allowable common and axial loads of vehicles (load capacity, extra-loads passing etc);
- Calculation, planning and optimization of maintenance and repair costs;
- Mapping the structures location on the electronic map according to the coordinates input;
- Bridge (or other kinds of facilities) stock performances analysis for long-term planning and development the relevant technical strategies and programs, research goals, improvement of the regulatory and methodological base, etc.
- Formation and printing of standardly formalized reporting documentation.

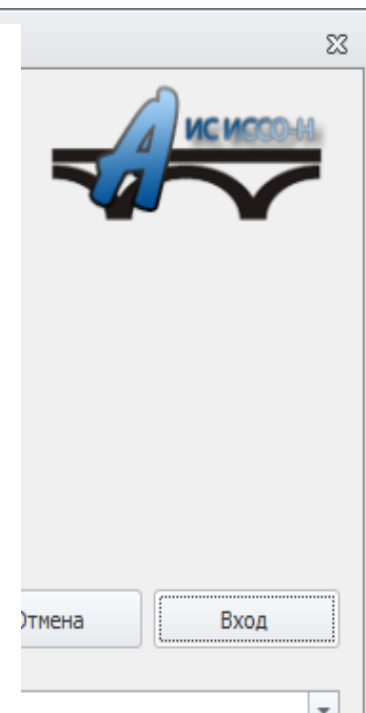

# AIS ISSO-N functioning by operating levels

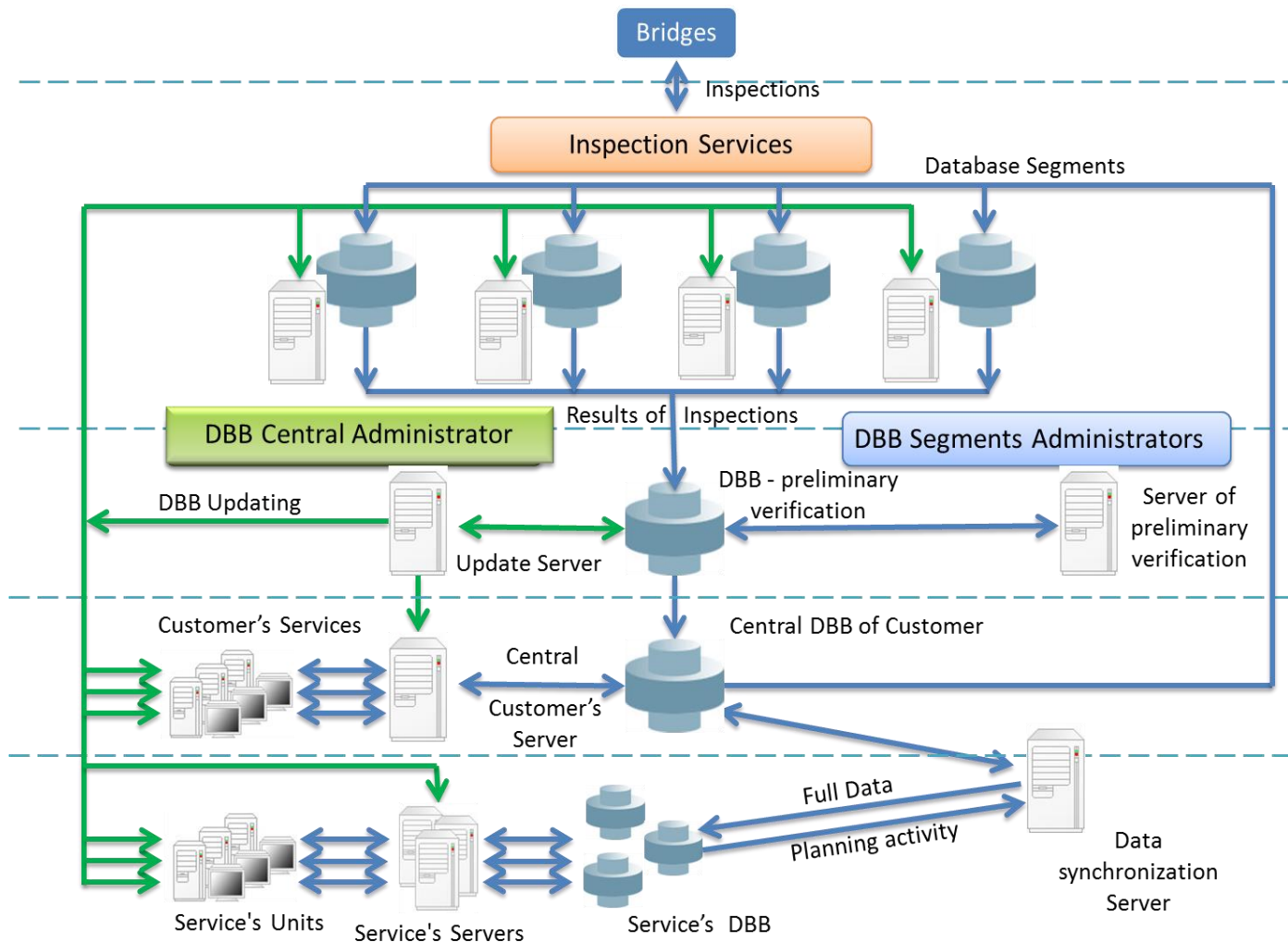

# The initial window of AIS ISSO-N

The screenshot shows the main window of the AIS ISSO-N software. At the top, there is a menu bar with options like 'Главная', 'Справка', and 'О программе'. Below the menu is a toolbar with icons for various functions. The main area contains a table with columns for bridge details. A detailed view of a bridge is shown on the right side of the window.

Labels pointing to various parts of the interface include:

- Portal
- List of bridges
- Data Export
- Routing lists
- Maintenance works
- Search
- Loads
- Reports
- Costs
- Region
- Working lists
- Verification
- Extra-loads passing
- Road Operational Unit

A red arrow points from the table to a detailed view of a bridge, with the text: "To an individual road, bridge, unit etc".

№	Управление	Сооружение	Тип ИССО	Дополнительн...	Название автодороги	Местоположение...	Тип основного препятст...	Название основного пр...	Регион расположения	Эксплуатаци...
31	ПКУ НСО ТУАД	Мост	Железобетонный мост		К-13 54 км а/д "М-52" - Завьялово - Фа...	55+909	постоянный водоток	р.Атананиха		
32	ПКУ НСО ТУАД	Мост	Железобетонный мост		К-14 105 км а/д "М-52" - Сузун	12+095	постоянный водоток	р.Крутишка		
33	ПКУ НСО ТУАД	Путепровод	Железобетонный мост		К-14 105 км а/д "М-52" - Сузун	82+193	железная дорога	ж/д "Входная-Алтайска		
34	ПКУ НСО ТУАД	Мост	Железобетонный мост		К-14н1 13 км а/д "К-14" - Карагужево	0+451	постоянный водоток	р.Иня		
35	ПКУ НСО ТУАД	Мост	Железобетонный мост		К-14н2 Подъезд к Шипуново /56 км/	2+069	постоянный водоток	р.Холодная		
36	ПКУ НСО ТУАД	Мост	Металлический мост		К-15 105 км а/д "М-52" - Черепаново - ...	33+287	постоянный водоток	р.Саева		
37	ПКУ НСО ТУАД	Мост	Железобетонный мост		К-15 105 км а/д "М-52" - Черепаново - ...	58+815	постоянный водоток	р.Стреленка		
38	ПКУ НСО ТУАД	Мост	Металлический мост		К-15 105 км а/д "М-52" - Черепаново - ...	65+974	постоянный водоток	р.Бердь		
39	ПКУ НСО ТУАД	Мост	Железобетонный мост		К-16 130 км а/д "М-53" - Тогучин - Кар...	4+163	постоянный водоток	р.Лебяжья		
40	ПКУ НСО ТУАД	Мост	Железобетонный мост							
41	ПКУ НСО ТУАД	Мост	Железобетонный мост							
42	ПКУ НСО ТУАД	Мост	Железобетонный мост	левый						
43	ПКУ НСО ТУАД	Мост	Железобетонный мост	правый	К-17р Новоосибирск - Кочки - Павлодар...	22+615	постоянный водоток	р.В.Тула		
44	ПКУ НСО ТУАД	Мост	Железобетонный мост		К-17р Новоосибирск - Кочки - Павлодар...	34+499	периодический водоток	Канал		
45	ПКУ НСО ТУАД	Мост	Металлический мост		К-17р Новоосибирск - Кочки - Павлодар...	36+420	постоянный водоток	р.Тула		
46	ПКУ НСО ТУАД	Мост	Железобетонный мост		К-17р Новоосибирск - Кочки - Павлодар...	64+500	постоянный водоток	р.Махалиха		
47	ПКУ НСО ТУАД	Мост	Железобетонный мост		К-17р Новоосибирск - Кочки - Павлодар...	67+889	постоянный водоток	р.Ирмень		
48	ПКУ НСО ТУАД	Мост	Железобетонный мост		К-17р Новоосибирск - Кочки - Павлодар...	95+140	постоянный водоток	р.Шарап		
49	ПКУ НСО ТУАД	Мост	Металлический мост		К-17р Новоосибирск - Кочки - Павлодар...	104+000	постоянный водоток	р.Орда		
50	ПКУ НСО ТУАД	Мост	Железобетонный мост		К-17р Новоосибирск - Кочки - Павлодар...	129+805	постоянный водоток	Шенчинный лог		
51	ПКУ НСО ТУАД	Мост	Железобетонный мост		К-17р Новоосибирск - Кочки - Павлодар...	133+730	периодический водоток			
52	ПКУ НСО ТУАД	Мост	Металлический мост		К-17р Новоосибирск - Кочки - Павлодар...	180+039	постоянный водоток	Ручей	Новосибирская область	ООО "МТ-СТР"
53	ПКУ НСО ТУАД	Мост	Железобетонный мост		К-17р Новоосибирск - Кочки - Павлодар...	186+755	постоянный водоток	р.Карасук	Новосибирская область	ООО "МТ-СТР"

Road Administration      Bridge characteristics      Road name      Location      Type & name of obstruction

# Main user's function modules of AIS ISSO-N

- Input, viewing and processing of data on structural elements, defects and other characteristics -

provides a simple and effective procedure for entering the database the necessary information with possibility of further quick access for viewing and adjusting it.

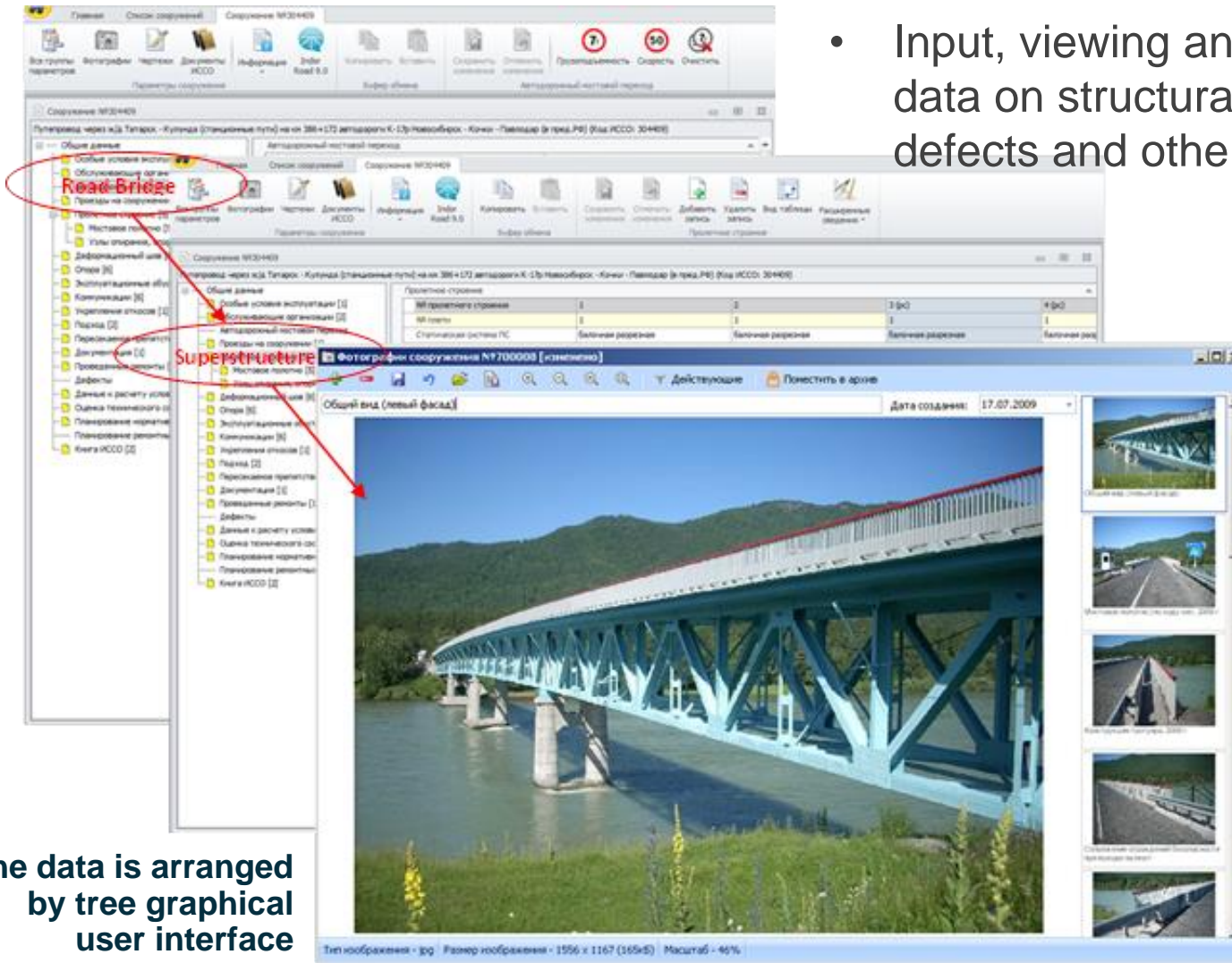

The data is arranged by tree graphical user interface

# Main user's function modules of AIS ISSO-N

The screenshot displays the AIS ISSO-N software interface for managing defects in a bridge structure. The main window shows a list of defects with columns for defect number, construction type, element, name, and severity indicators (B, D, P, G) and dates.

№	Конструкция	Элемент в конструкции	Название дефекта	Б	Д	Р	Г	Даты
25	Пролетное строение №1	Главные несущие конструкции. Железобетонные сплошнстенчатые. Продольный шов моноличивания в	Выщелачивание цементного камня с отложением солей на поверхности	0	2	2	да/нет	17.08.2015 / [не устранен]
26	Пролетное строение №1	Главные несущие конструкции. Железобетонные сплошнстенчатые	Обводнение конструкций	0	1	2	нет	17.08.2015 / [не устранен]
27 (ф)	Пролетное строение №1	Главные несущие конструкции. Железобетонные сплошнстенчатые	Излом элемента конструкции	0	2	3	да/нет	17.08.2015 / [не устранен]
28 (ф)	Пролетное строение №1	Главные несущие конструкции. Железобетонные сплошнстенчатые	Сколы механические	0	1	2	нет	17.08.2015 / [не устранен]
29 (ф)	Пролетное строение №3	Главные несущие конструкции. Железобетонные сплошнстенчатые	Пролон в элементе конструкции	0	3	3	да	17.08.2015 / [не устранен]
30 (ф)	Пролетное строение №3	Главные несущие конструкции. Железобетонные сплошнстенчатые. Продольный шов моноличивания в	Раковины в бетоне	0	1	2	нет	17.08.2015 / [не устранен]
31 (ф)	Пролетное строение №3	Главные несущие конструкции. Железобетонные сплошнстенчатые. Продольный шов моноличивания в	Выщелачивание цементного камня с отложением солей на поверхности	0	2	2	да/нет	17.08.2015 / [не устранен]
32 (ф)	Пролетное строение №3	Главные несущие конструкции. Железобетонные сплошнстенчатые	Скол силовой	0	1	2	нет	17.08.2015 / [не устранен]
33 (ф)	Пролетное строение №3	Главные несущие конструкции. Железобетонные сплошнстенчатые	Расслоение защитного слоя бетона в результате коррозии арматуры	0	2	2	да/нет	17.08.2015 / [не устранен]
34 (ф)	Пролетное строение №3	Главные несущие конструкции. Железобетонные сплошнстенчатые	Скол силовой	0	1	1	нет	17.08.2015 / [не устранен]

Below the main table, there are sections for 'Степень развития. Определяющие параметры' and 'Дополнительные характеристики дефекта'.

**Степень развития. Определяющие параметры**

Параметр	Значен...	Значен...		
Состояние дефекта от 17.08.2015 (ф)	0	2	3	да/нет
Состояние дефекта от 30.11.2016 (ф)	0	3	3	да
Несущая способность конструкции ниже уровн...	0	3	3	да

**Дополнительные характеристики дефекта**

Локализация	Плита и шов моноличивания между Б2 и Б3 над опорой №3
Дополнительная информация	Вследствие деградационного разрушения бетона при регулярном обводнении и динамического воздействия временной нагрузки в зоне

**Характеристика дефекта по ремонтпригодности**

Прямая ремонтная работа	Ремонт монолитного продольного шва объединения балок в пролетно...
Объем ремонтной работы, куб.м	0.500

On the right side, there is a 'Параметр' section showing technical indicators:

Показатель	Значен...	Значен...
Общая оценка (категория) техниче...	неудов...	неудов...
Показатель габарита проезжей части Кпч	4	
Показатель подмостового габарита Кпг	5	
Показатель габарита проходной части Ктр	5	
Показатель вида ремонтного воздействи...	3	3
Обобщенный показатель технического с...	2.276	2.276
Показатель технического состояния по г...		2
Показатель технического состояния по б...	3	3
Показатель технического состояния по ...	2.654	2.654
Показатель технического состояния по ...	3.308	3.308
Показатель технического состояния по ...	2	2
Обобщенный параметр дефектности соо...	2.413	2.413
Параметр дефектности по безопасности Вб	3.906	3.906
Параметр дефектности по безопасности	2.570	2.570

- Input, viewing and processing of defects, as performance indicators



# Main user's function modules of AIS ISSO-N

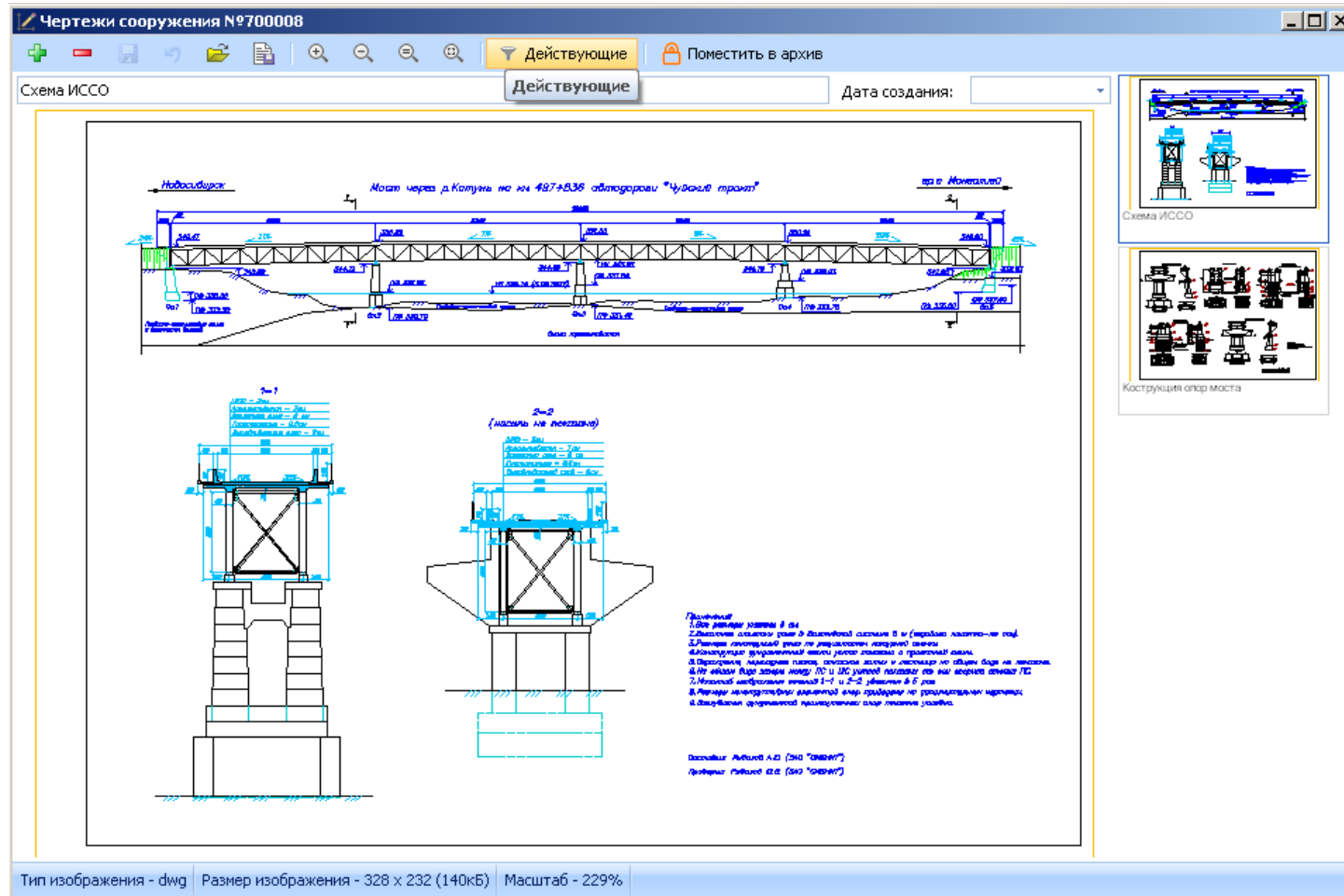

- Input, viewing and editing drawings

# Main user's function modules of AIS ISSO-N

Каталог типовых проектов

Тип конструкции: Опорные части | Фрагмент названия: Резин

Серия, номер	Название	Автор	Год
Тема 36К-ИС-67-70	Рабочие чертежи комбинированных резиновых слоистых опорных частей автодорожных и городских мостов	СОЮЗДОРПРОЕКТ Киевски...	1970
Тема 802К-ИС-80	Резиновые слоистые опорные части автодорожных мостов с опытом применения. Тема 802К-ИС-80 №293 от 30.10.80		
Опорные части ООО "ДШР"	Резиновые опорные части, поставляемые ООО "ДШР"		
Опорные части ООО "РУССЕРВМОСТ"	Резиновые опорные части, поставляемые ООО "РУССЕРВМОСТ"		

Примечание

Расширенный каталог железобетонных пролетных строений

Серия, инв.№	Материал	Основная несущая конструкция	Расчетная нагрузка	Длина	Высота	Габарит ПЧ	Число ГБ
Выпуск 56 (доп.), Инв.№147/2	железобетон	балки ребристые...	H-13, НГ-60 (Гу...	8.66	0.70	Г6	5
Выпуск 56 (доп.), Инв.№147/2	железобетон	балки ребристые...	H-13, НГ-60 (Гу...	8.66	0.70	Г7+2х0,75	5
Выпуск 56 (доп.), Инв.№147/2	железобетон	балки ребристые...	H-13, НГ-60 (Гу...	8.66	0.70	Г7+2х1,5	6
Выпуск 56 (доп.), Инв.№147/2	железобетон	балки ребристые...	H-18, НК-80 (Н ...	8.66	0.70	Г7+2х0,75	5
Выпуск 56 (доп.), Инв.№147/2	железобетон	балки ребристые...	H-18, НК-80 (Н ...	8.66	0.70	Г7+2х1,5	6
Выпуск 56 (доп.), Инв.№147/2	железобетон	балки ребристые...	H-18, НК-80 (Н ...	8.66	0.70	Г8+2х0,75	6
Выпуск 56 (доп.), Инв.№147/2	железобетон	балки ребристые...	H-18, НК-80 (Н ...	8.66	0.70	Г8+2х1,5	7
Выпуск 56 (доп.), Инв.№147/2	железобетон	балки ребристые...	H-13, НГ-60 (Гу...	11.36	0.80	Г6	5
Выпуск 56 (доп.), Инв.№147/2	железобетон	балки ребристые...	H-13, НГ-60 (Гу...	11.36	0.80	Г7+2х0,75	5
Выпуск 56 (доп.), Инв.№147/2	железобетон	балки ребристые...	H-13, НГ-60 (Гу...	11.36	0.80	Г7+2х1,5	6
Выпуск 56 (доп.), Инв.№147/2	железобетон	балки ребристые...	H-13, НГ-60 (Гу...	11.36	0.80	Г7+2х0,75	5
Выпуск 56 (доп.), Инв.№147/2	железобетон	балки ребристые...	H-18, НК-80 (Н ...	11.36	0.80	Г7+2х1,5	6
Выпуск 56 (доп.), Инв.№147/2	железобетон	балки ребристые...	H-18, НК-80 (Н ...	11.36	0.80	Г7+2х0,75	6
Выпуск 56 (доп.), Инв.№147/2	железобетон	балки ребристые...	H-18, НК-80 (Н ...	11.36	0.80	Г8+2х0,75	6
Выпуск 56 (доп.), Инв.№147/2	железобетон	балки ребристые...	H-18, НК-80 (Н ...	11.36	0.80	Г8+2х1,5	7
Выпуск 56 (доп.), Инв.№147/2	железобетон	балки ребристые...	H-13, НГ-60 (Гу...	14.06	0.85	Г6	5

Конструктор фильтра...

Параметр | Значение

- Типовой проект
- Серия, инв.№ | Выпуск 56 (доп.), Инв.№147/2
- Название | Типовые проекты сооруженной на ...
- Организация | СОЮЗДОРПРОЕКТ
- Год | 1962
- Примечание | утв. 4.06.1962 г.
- Балка
  - Материал | железобетон
  - Основная несущая к... | балки ребристые без диафрагм
  - Расчетная нагрузка | H-18, НК-80 (H 106-53)
  - Способ поперечного ... | по плите
  - Тип проезжей части | ж/б плита в составе осн.несущ.ко...
  - Способ продольного ... | отсутствует
  - Длина ПС (полная), м | 11.36
  - Длина ПС (расчетная... | 11.1
  - Высота в пролете, м | 0.8
  - Ширина балки, м | 1.3
  - Толщина ребра, м | 0.2
  - Толщина плиты, м | 0.15
  - Кол-во диафрагм
  - Высота диафрагм, м
  - Толщина диафрагм, м
  - Вес, т | 10.3
  - Несущая способность...
  - Несущая способность...
  - Примечания
- Пролетное строение
  - Габарит ПЧ | Г7+2х0,75
  - Поперечная схема ПС | К0,75+4х1,66+К0,75
  - Полная ширина ПС, м | 8.14
  - Число ГБ ПС | 5
  - Примечания

Применить | Отмена

Всего записей в каталоге 969, показано 28

The information reference system for typical structures

# Main user's function modules of AIS ISSO-N

The system provides automatic calculation of influence surfaces, load capacity and the possibility of extra-weights passing for most types of superstructures.

**Сооружение №700037**  
Железобетонный мост через р.Айгулак на км 761.858 автодороги "Чуйский тракт" Новосибирск - Барнаул - Горно-Алтайск - граница с Монголией

**Данные к расчету условий пропуска**

№ проверки	1	2	3	4	5
№ пролетного строения размещения проезда для проверяемой конструкции	1	1	1	1	1
Тип проверяемой несущей конструкции	Пролетное стро...	Пролетное стро...	Пролетное стро...	Пролетное стро...	Пролетное стро...
№ проверяемой несущей конструкции					
Тип элемента и расчетной проверки	Железобетонн...	Железобетонн...	Железобетонн...	Железобетонн...	Железобетонн...
Название элемента и места проверки	Б1 в середине пролета	Б2 в середине пролета	Б3 в середине пролета	Б4 в середине пролета	Б5 в середине пролета
Наличие симметричного элемента	<input checked="" type="checkbox"/>	<input checked="" type="checkbox"/>	<input checked="" type="checkbox"/>	<input type="checkbox"/>	<input type="checkbox"/>
Положение левой границы проезда относительно левой границы ПВ, м	0.81	0.81	0.81	0.81	0.81
Лямбда (к определению дин. коэф.)	11.40	11.40	11.40	11.40	11.40
Проектные нагрузки	H-30, НК-80 (СН...)	H-30, НК-80 (СН...)	H-30, НК-80 (СН...)	H-30, НК-80 (СН...)	H-30, НК-80 (СН...)

**Точка А,  $\sigma_{yp}$ , кПа**  
МАКС. 2771

**Точка В,  $\sigma_{yp}$ , кПа**  
-2664

**Точка С,  $\sigma_{yp}$ , кПа**  
МАКС. -88.80

3D представление  
В плане

По изгибающему моменту...  
100.100  
ружки 38.219  
грузки 0.000  
к 0.000

ВЛИЯНИЯ

# Main user's function modules of AIS ISSO-N

Режим выделения    Показать коды ИССО на карте    Показать список ИССО

## ИССО на картах

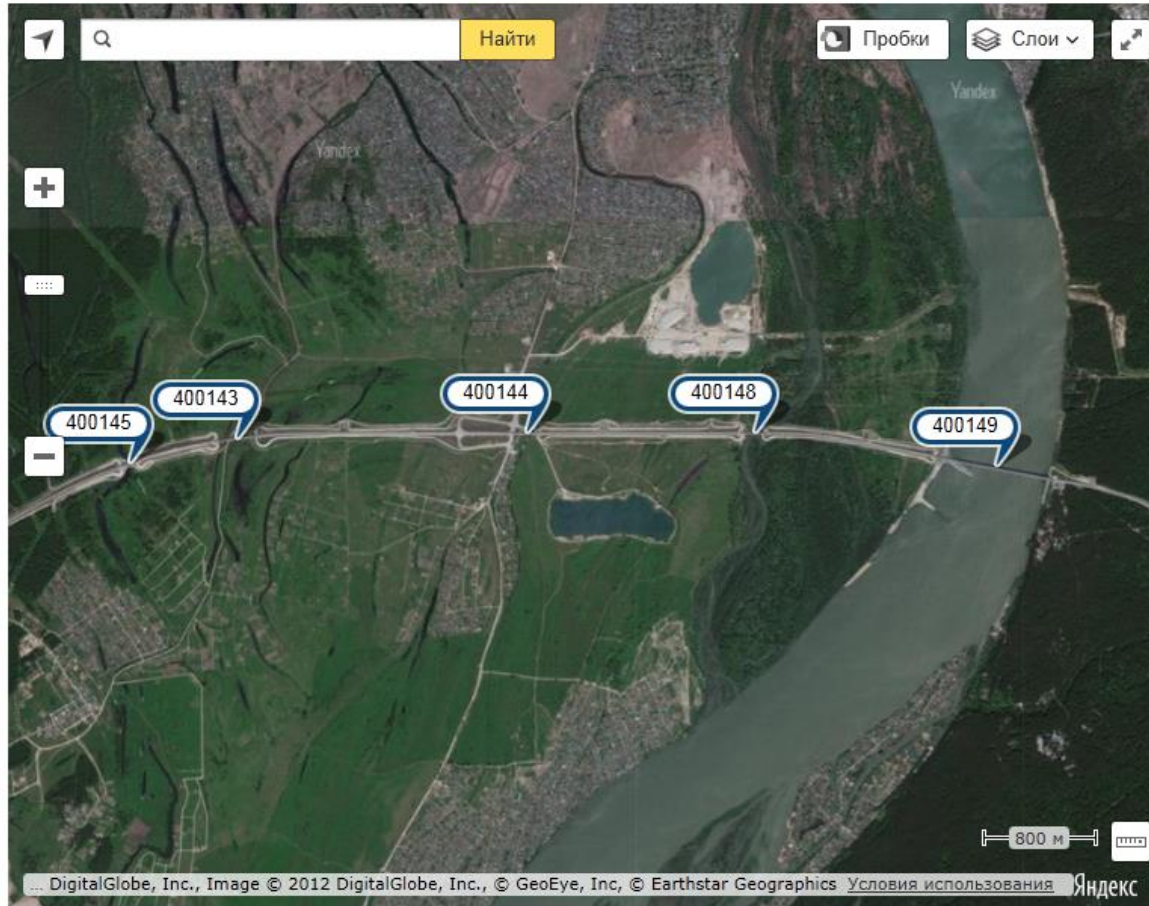

1. Железобетонный мост через оз.Алферово на км 31+469 автодороги Северный обход г.Новосибирска (Р-254) (Код ИССО 400145)
2. Железобетонный мост через оз.Хомутино на км 32+272 автодороги Северный обход г.Новосибирска (Р-254) (Код ИССО 400143)
3. Железобетонный мост через оз.Старица на км 34+367 автодороги Северный обход г.Новосибирска (Р-254) (Код ИССО 400144)
4. Металлический мост через Протока р.Обь на км 36+020 автодороги Северный обход г.Новосибирска (Р-254) (Код ИССО 400148)
5. Металлический мост через р. Обь на км 37+793 автодороги Северный обход г.Новосибирска (Р-254) (Код ИССО 400149)

Mapping the structures location on the electronic map according to the coordinates input

# Automated technical condition assessment

## Key Performance Indicators (KPIs):

- Safety
- Reliability
- Longevity
- Maintainability
- Cost
- Load Carrying Capacity

**Сооружение №700037**  
Железобетонный мост через р.Айгулак на км 761.858 автодороги "Чуйский тракт" Новосибирск - Барнаул - Горно-Алтайск - граница с Монголией

Оценка технического состояния				
Дата назначения ОТС	25.07.2001	24.08.2005	15.10.2007	28.04.2011
Экспертная оценка состояния	удовлетворительное	хорошее	удовлетворительное	удовлетворительное
Тип освидетельствования	диагностика	диагностика	периодический осмотр	диагностика
Необходимость дополнительного обследования	нет необходимости	нет необходимости	нет необходимости	нет необходимости
Эксперт	Рыбалов Юрий (ryba@...)	Рыбалов Юрий (ryba@...)	Рыбалов Юрий (ryba@...)	Рыбалов Юрий (ryba@...)
Организация, проводящая спец.осмотр	ЗАО "СИБНИТ" (Новоси...)	ЗАО "СИБНИТ" (Новоси...)	ЗАО "СИБНИТ" (Новоси...)	ЗАО "СИБНИТ" (Новоси...)

Параметр	Оценка состояния по ОДМ218.3.014-2011		
	Значения по рекомен...	Значения по экспертн...	Значения по назначе...
<b>Общая оценка (категория) технического состояния</b>	<b>удовлетворительное</b>	<b>удовлетворительное</b>	<b>удовлетворительное</b>
Показатель габарита проезжей части Кпч	5		5
Показатель подмостового габарита Кпг	5		5
Показатель габарита проехой части Кпр	5		5
Показатель вида ремонтного воздействия Кр	4	4	4
Обобщенный показатель технического состояния Коб	3.19	3.19	
Показатель технического состояния по грузоподъемности Кг	4	4	
Показатель технического состояния по безопасности Кб	3	3	
Показатель технического состояния по долговечности Кд	3.17	3.17	
Показатель технического состояния по долговечности Кд(ср)	3.33	3.33	
Показатель технического состояния по долговечности Кдmin	3	3	
Обобщенный параметр дефектности сооружения Воб	3.80	3.80	
Параметр дефектности по безопасности Вб	3.79	3.79	
Параметр дефектности по долговечности Вд	3.75	3.75	
Параметр дефектности по ремонтпригодности Вр	3.49	3.49	
Допустимый класс нагрузки АК (Как)		12.35	
Допустимый класс нагрузки НК (Кнк)		101.50	

## PI intended to assess traffic safety are derived in units of velocity (m/s):

- The driving speed initially set by the Design Codes;
- The safe speed calculated taking given detected defects
- The safe speed in terms of carriageway width and traffic density;
- The safe speed in terms of road safety barriers performance;
- The safe speed in terms of road surface and profiles performance;
- The safe speed in terms of rain storm water spillway performance.

The Load Carrying Capacity is calculated also in physical units of load capacity class (tons) for load patterns “AK” and “NK” provided by Russian design standards, using the input from inspections data. The input data for load carrying capacity calculating also provide the automated calculation of the possibility of passing a load with arbitrary parameters of the axial scheme and weights.

# Assessment by five-point scale by the PIs:

- The generalized indicator of technical condition;
- The roadway width overall dimension indicator;
- The under-bridge clearance indicator;
- The footway width overall dimension indicator;
- The indicator of required repair volume;
- The generalized load carrying capacity indicator;
- The traffic safety indicator;
- The longevity indicator;
- The generalized prevalence of defects indicator;
- The prevalence of defects indicator by traffic safety criterion;
- The prevalence of defects indicator by longevity criterion;
- The prevalence of defects indicator by maintainability criterion.

Finally, the generalized assessments by a five-point scale for the next KPIs are output: Load Carrying Capacity, Safety, Longevity, Maintainability.

# “Cost” is assessed by functional modules:

- Planning and calculating the costs of routine maintenance;
- Planning and calculating the costs of heavy maintenance;
- Planning and calculating the costs of inspections (survey, diagnostics etc);
- Planning and accounting the costs of current programs of design and survey works;
- Planning and accounting the costs of current programs of repairs and reconstructions.

These modules, unlike the other KPIs, were completely absent in the previous AIS-ISSO-H systems. Now it became possible on the Cost basis to make a Life Cycle Analysis (LCA) and calculate the LCC of artificial road structures.



# HMS as a part of BMS, e.g. “Russkiy” bridge

They are value, but unique, “bespoke” and very expensive systems.

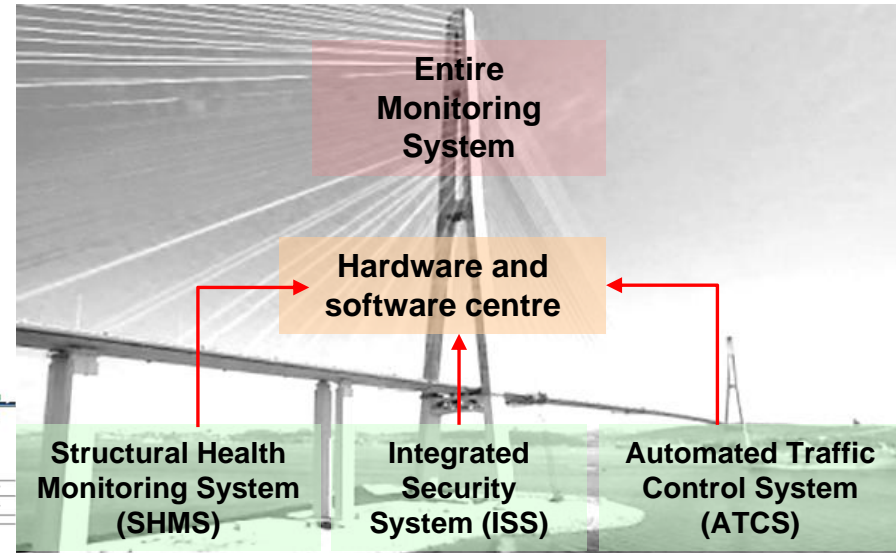
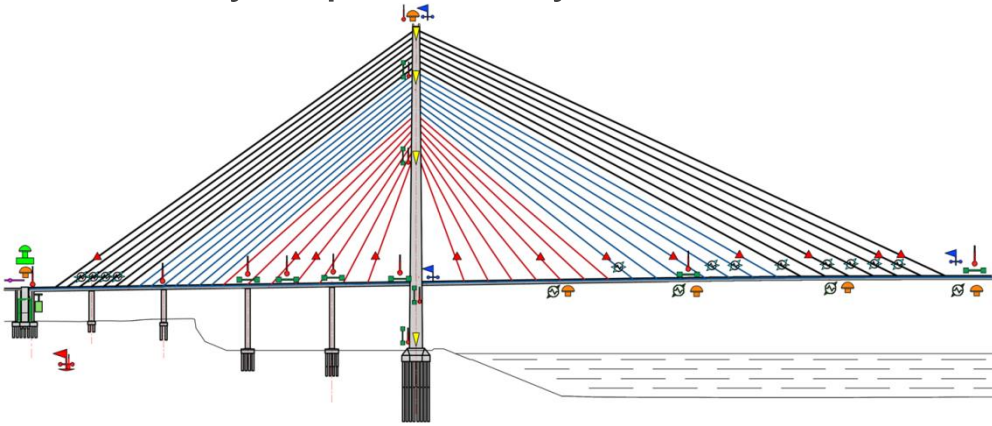

- ❖ Record-breaking main span length – 1104 m
- ❖ Record-breaking pylon height – 324 m
- ❖ Navigation clearance – 70 m
- ❖ Wind speed till 64 m/s at pylon top level
- ❖ Seismic load: intensity of Mw 8.1

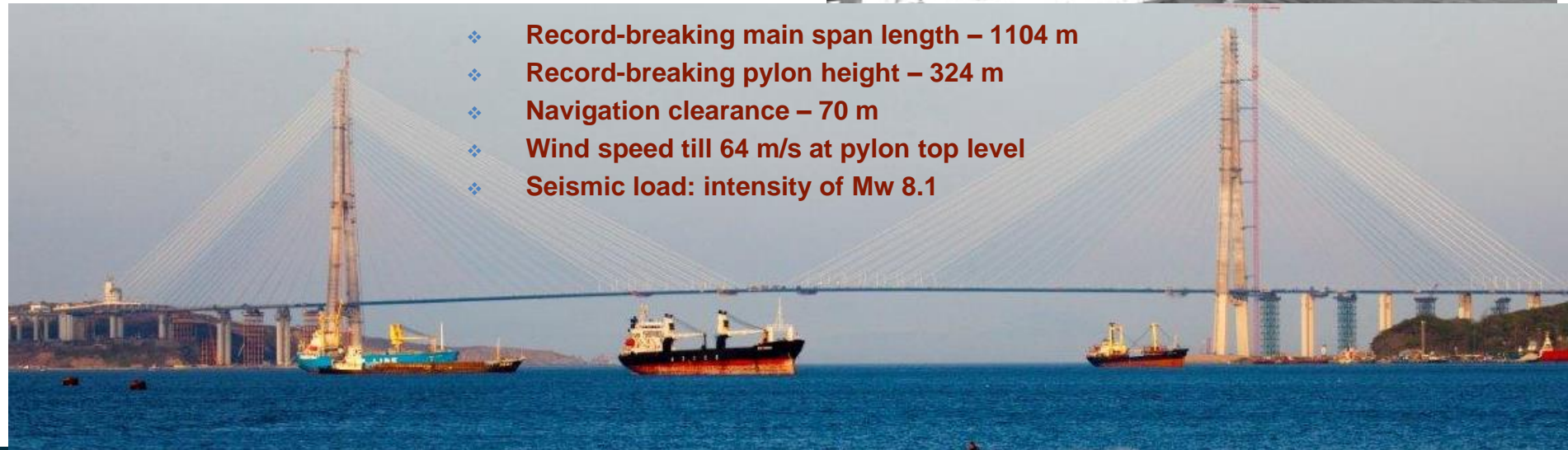

# The world trend of failures increasing exists

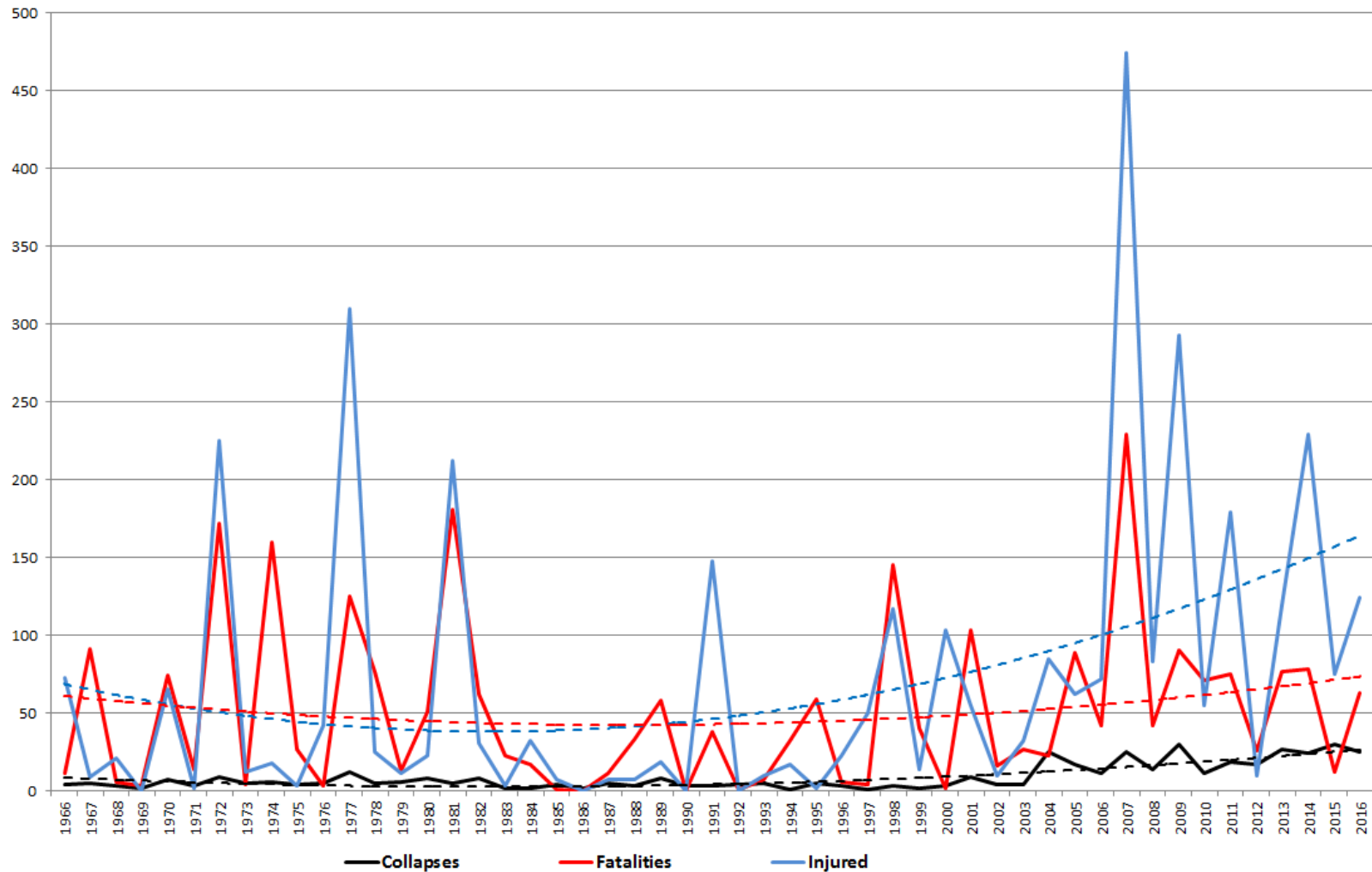

# Types of errors & causes for bridge collapses

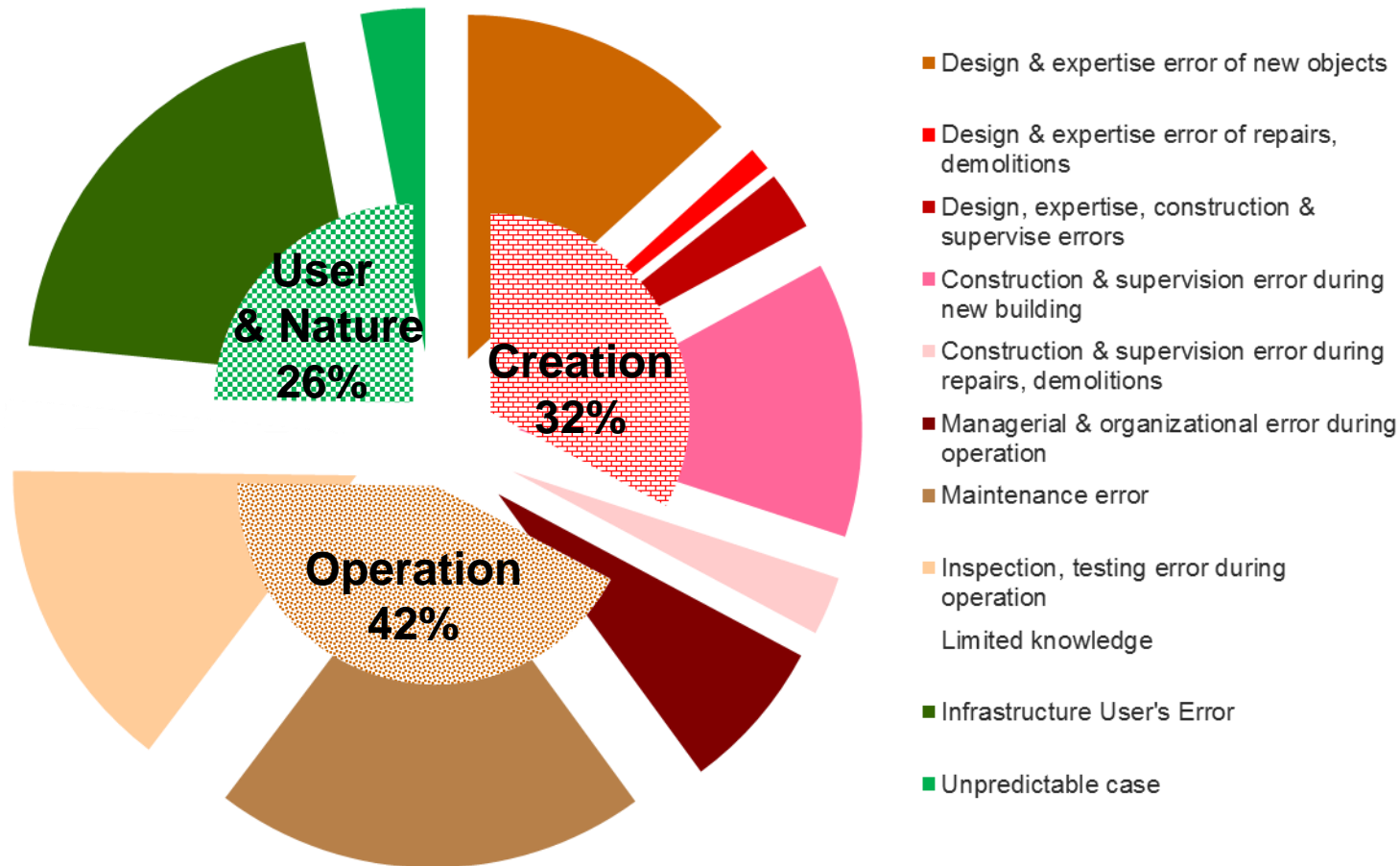

# Collapses for 4 countries in the past 50 years

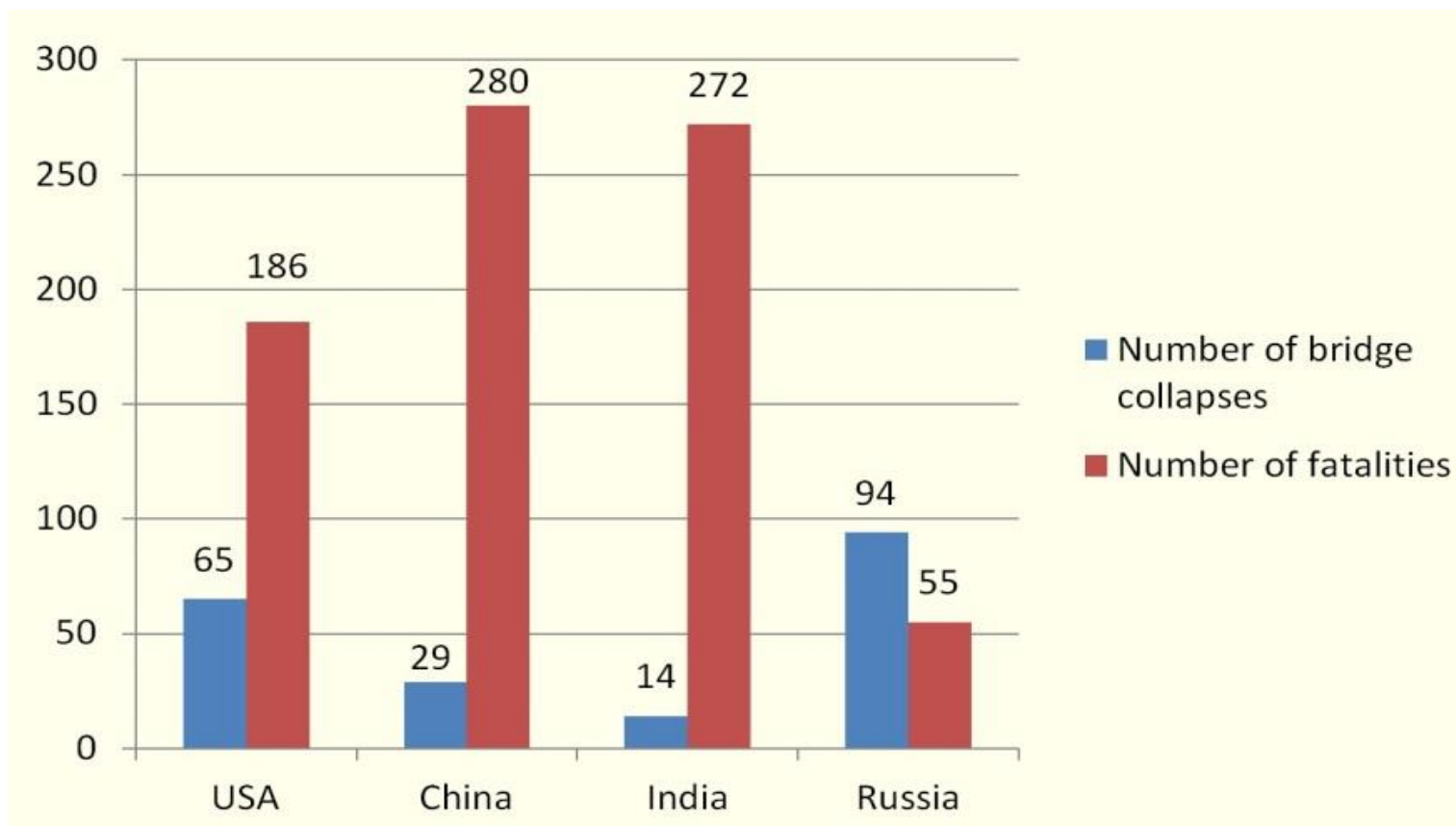

# BMS needs new synergetic strategies

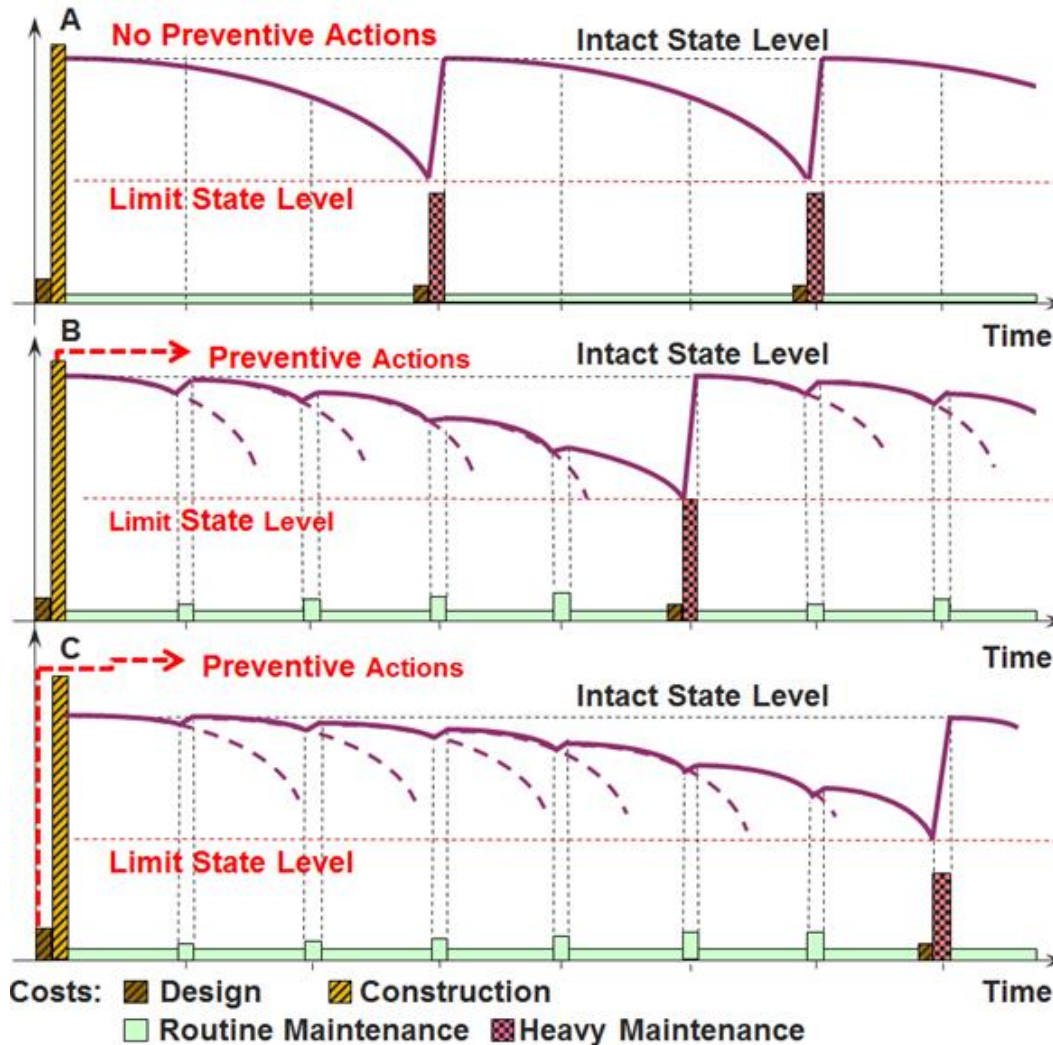

# Feedback processes must be used

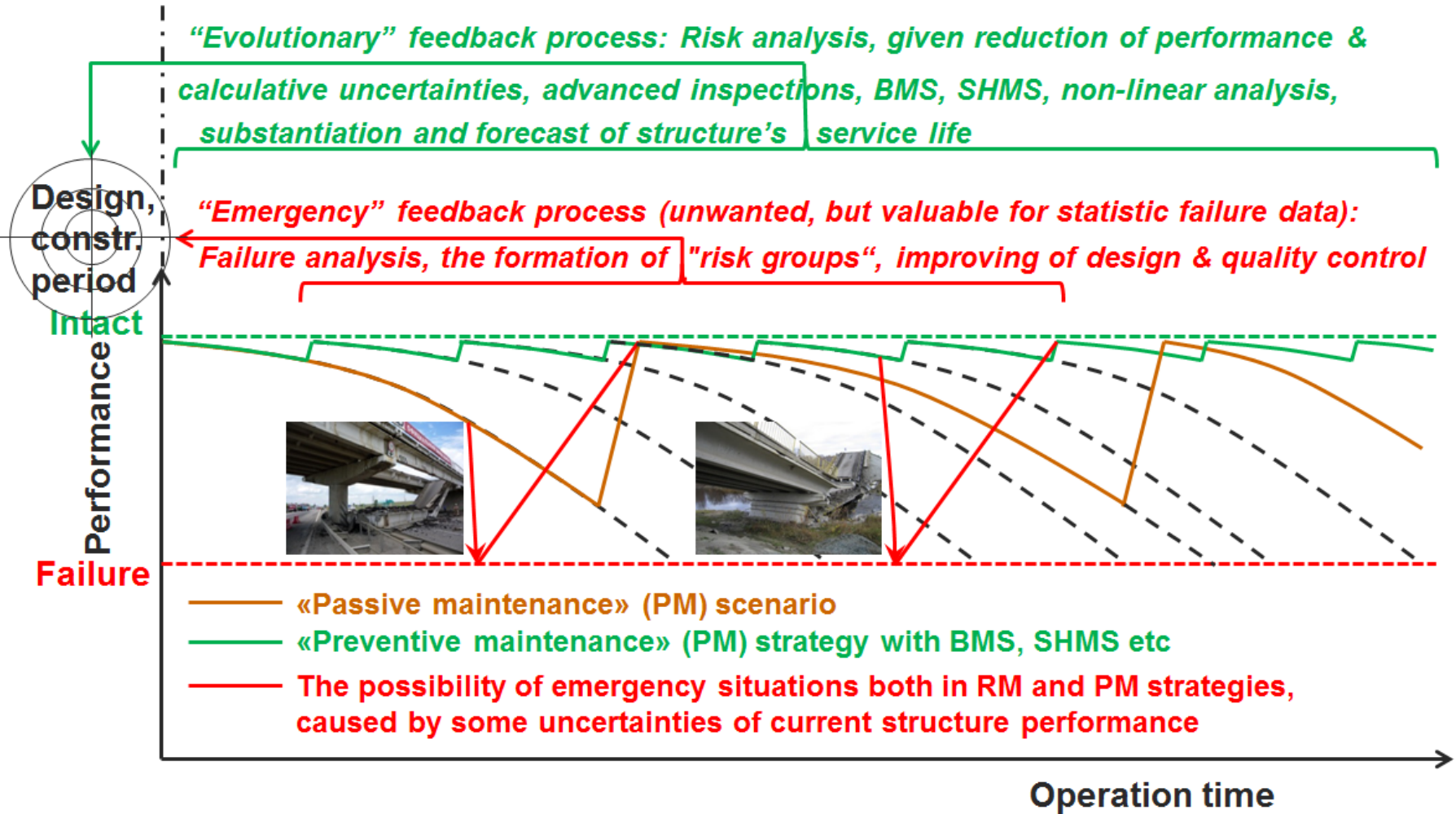

# BMS needs massive reassessments of risks

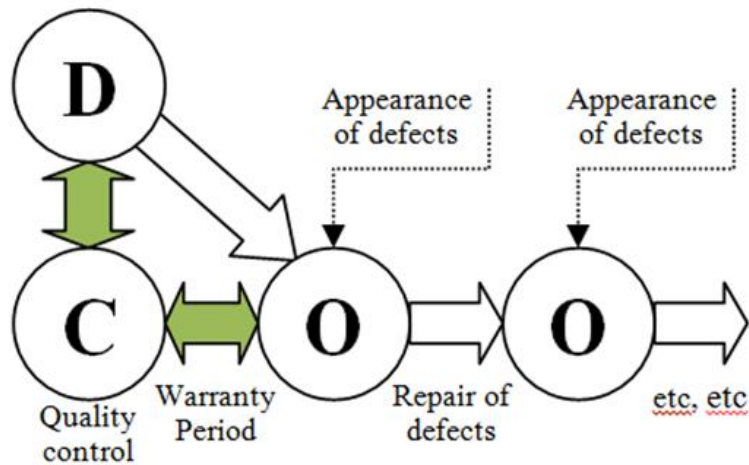

**An outdated approach to life cycle processes organization (D - Design; C - Construction; O – Operation)**

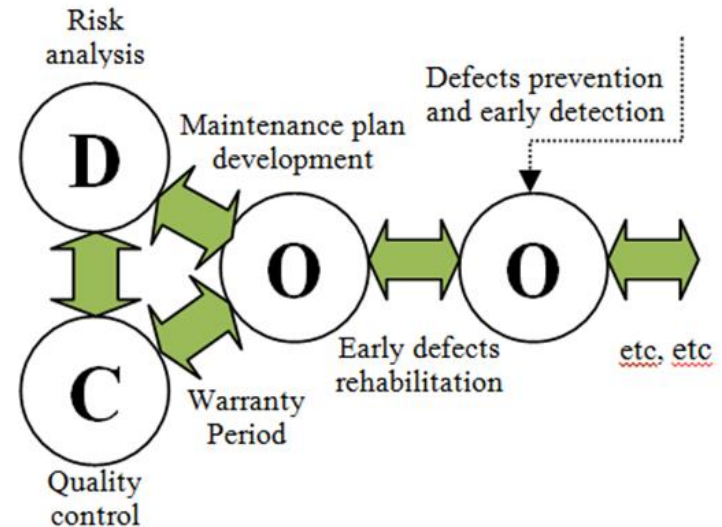

**A progressive approach to life cycle processes organization, having all mutual feedbacks, risk analysis and maintenance plan development**

# The degree of risk is a relative value

An attempt to increase the effectiveness of the Risk Matrices method was undertaken recently in Russia.

At the first stage, the risk groups of bridge structures were determined using data on near-failure states and failures, up to collapses. Then the fault trees were developed with identifying of some PIs, signaling that the process of destruction is developing.

The identified PIs received special scores for types of structures assigned to risk groups, depending on the degree of development of defects detected during routine inspections. The obtained scores for PIs that are responsible for "alarming signs" were then used in the algorithm for recalculating the criticality of risks, embedded in a special BMS subprogram. In the same place, pre-entered data on the possible severity of consequences for objects from risk groups were also used.

This method, unofficially named as "reconnaissance risk analysis" in the spring of 2017 was used in the framework of a specific task to determine the priority of non-destructive tests (NDT) of prestressed bridge beams reinforcement by a magnetic method using an instrument developed by the Russian company "INTRON +"



# A fault tree example for prestressed beams

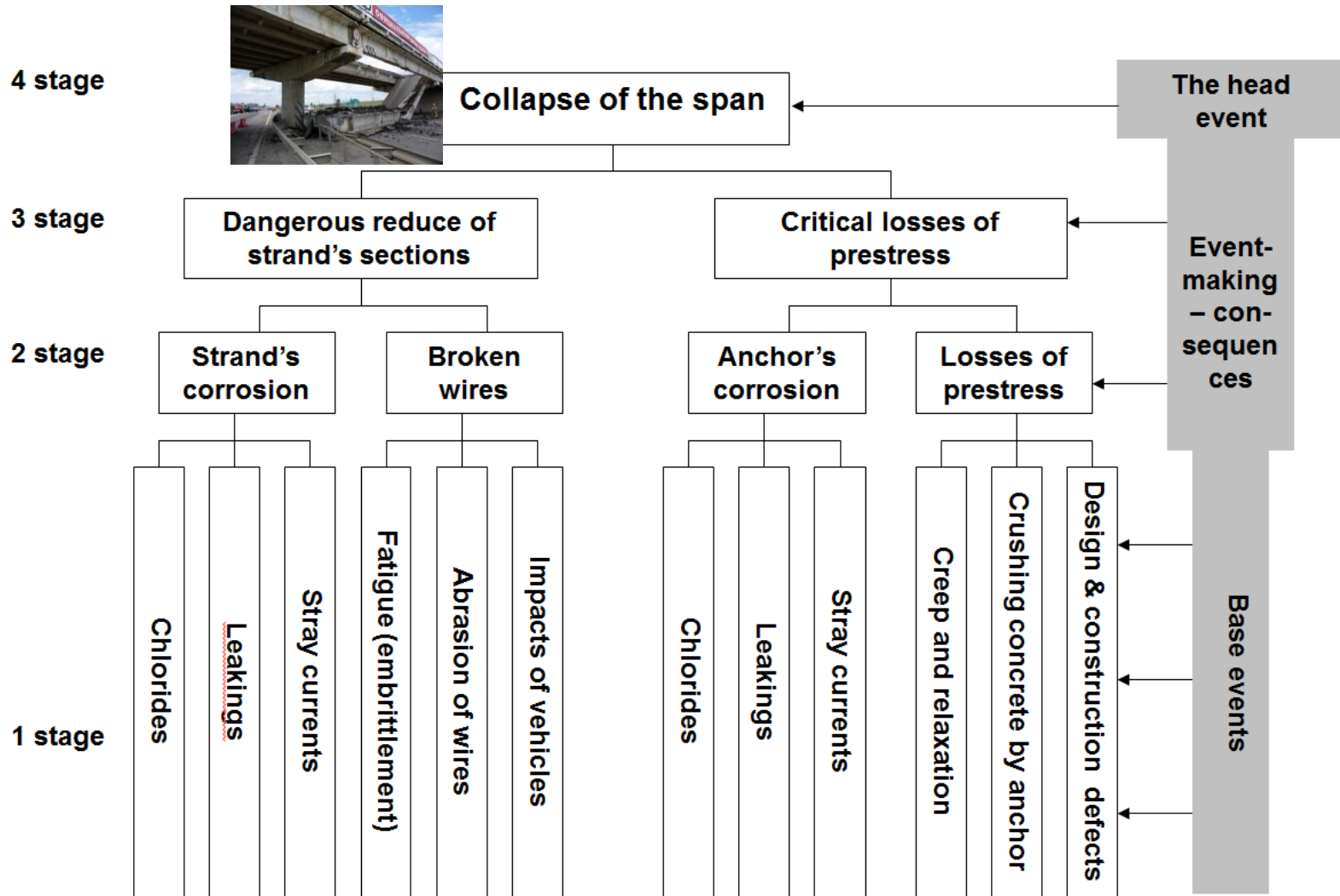

## E.g. determination of the priority of NDT



# Conclusions

- The Russian Bridge Management System has been substantially modernized over the past decade. It was equipped with a modern analytical information program complex capable in an automated mode to assess the technical condition of road bridges, solve tasks of passing loads with arbitrary parameters of the axial scheme and weights, determine the cost of the life cycle and implement many other user's requests.
- The modern Russian Bridge Management System was developed mainly on the basis of reliability parameters. It may be used for different management levels and for all Russian types of artificial road structures.
- The methodology of the Russian Bridge Management System currently is based on the expert assessments of the defect's impact for the following Key Performance Indicators: Safety, Reliability, Longevity, Maintainability, Cost and Load Carrying Capacity.
- The nearest perspectives for the Russian BMS development are foreseen as the enhancing of new synergetic life cycle strategies, using feedback and risk analysis tools to develop a methodology on the prioritization of bridge diagnostic and rehabilitation activities. The targeted "reconnaissance risk analysis" method was developed and tested to solve a task to determine the priority of non-destructive tests of a vast set of prestressed bridge beams.



**TU1406**  
COST ACTION

**THANK FOR YOUR ATTENTION!**



**TU1406**  
COST ACTION

**WG3, WG4 and WG5 WORKSHOP**

**Sustainable Bridge Development**

# **CARBONIZATION AND SERVICE LIFE PREDICTION OF A HISTORICAL REINFORCED CONCRETE BRIDGE**

**Naida Ademovic- Faculty of Civil Engineering, University of Sarajevo**



**23<sup>rd</sup> – 24<sup>th</sup> November 2017**

**Riga, Latvia**

# Introduction

- A large amount of bridges existing in the heart of Sarajevo

- UNIQUE STORY
- VITAL TRANSPORTATION VAIN

THE TIME OF THEIR CONSTRUCTION VARIES:

- OTTOMAN EMPIRE
- AUSTRO-HUNGARIAN EMPIRE
- EX-YUGOSLAVIA



# Careva Ćuprija (Emperor's Bridge)

- oldest of all bridges in Sarajevo
- national monument
- built in 1897 - first single-arch reinforced concrete bridge in Sarajevo



- Corrosion of steel reinforcement is denoted as the leading cause of damage

## Corrosion of steel and carbonation of concrete

- Corrosion of steel in the reinforced concrete structures:
- **begins slowly** when exposed to the natural environment
- **more extensively** in the areas with **a high degree of carbon dioxide emitted from vehicles and industrial areas**
- The risk of carbonation is more severe in urban or/and industrial area
- Carbonization is a **slow process**, however it can be accelerated by several factors (THIS CASE):
  - **low strength of concrete**
  - **highly permeable and porous paste**
  - **low pH value** the chloride threshold for corrosion is significantly lower-at or below 100 ppm



# Extent of corrosion damage over time

PROCESS OF  
**CARBONATION** CANNOT  
BE PREVENTED

- **CHLORIDE INDUCTION**
- AND **CARBONATION** CONTRIBUTES TO THE CORROSION OF STEEL REINFORCEMENT

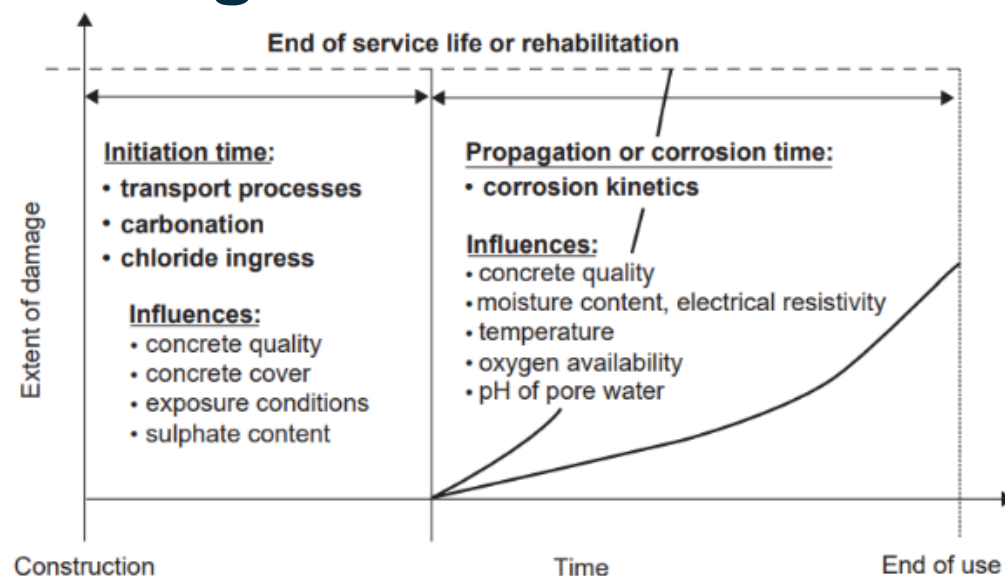

**COMPRESSIVE STRENGTH OF THE CONCRETE** STRUCTURE IS AFFECTED BY THE PROCESS OF CARBONATION

**CARBONATION DEPTH** HAS AN INVERSE RELATIONSHIP WITH THE COMPRESSIVE STRENGTH DEPENDING ON THE SERVICE LIFE OF THE CONCRETE

# Modelling the risk of carbonation

- representative techniques:
  - The safety factor method
  - the Monte Carlo simulation
- The safety factor
  - engineering judgment
  - value of **1.2** is recommended in various standards and guidelines
  - conservative approach
  - Some ERRORS
- THE MONTE CARLO SIMULATION
  - COMPLEX
  - limited study to consider qualities of cover concrete
  - Less USED

## Theoretical basis - Carbonization depth

- The depth of carbonation  $x$  in the reinforced concrete is affected by time  $t$  in days and the carbonation coefficient  $k$

Carbonization coefficient is determined on the basis of the **relative humidity (RH) percentage**

$$x = k\sqrt{t}$$

$$k_d = 0.556c - 3.602X - 0.148f_c + 18.734 \quad \text{RH is } \leq 70\% \text{ (mm/year}^{0.5}\text{)}$$

$$k_w = 3.556c - 0.019C - 0.042f_c + 10.83 \quad \text{RH is } > 70\% \text{ (mm/year}^{0.5}\text{)}$$

The carbonization depth and concrete cover depth were obtained from experiments conducted on the site

## Visual inspection and determination of bridge damage

- rigid reinforcement consisting of 2L sections measuring 60x60x4 mm (20 sets in total)



# STEEL CORROSION

- Extremely high degree of corrosion of the top rigid reinforcement
- presenting significant **"swelling"** due to an increase in the volume of reinforcement, which indicates that the reinforcement has been greatly affected by corrosion.
- highly exposed to rain and wind
- These parts are completely "stripped", exposed to active atmospheric actions

**general corrosion,**  
**with additional subsurface or**  
**layered corrosion.**



# carbonation of concrete

- forming carbonates
- **flow-assisted corrosion (corrosion of soft water)**
- The stalactites are approximately 20 cm in length and about half a centimeter in diameter
- **general acid corrosion.**



## Onsite investigations and laboratory tests

- The rigid reinforcement 2L 60 x 60 x 4mm=tensile strength of **470 N/mm<sup>2</sup>**, and the yielding strength of **285 N/mm<sup>2</sup>**
- concrete samples=**MB 20** (JUS standards), **C15/20**
- Significant corrosion of concrete can be observed on all samples



- **Low pH values** were determined, indicating unsatisfactory protection of reinforcement.
- It should be emphasized that an extremely **high open porosity with considerable absorption of water** originating from fill material located above the concrete has a direct impact on carbonation
- The concrete cover was measured with ultrasonic cover meter



## concrete cover

- 50 points were measured both on the cracked and on the sound material
- Carbonization on the site was determined by the application of the phenolphthalein pH indicator

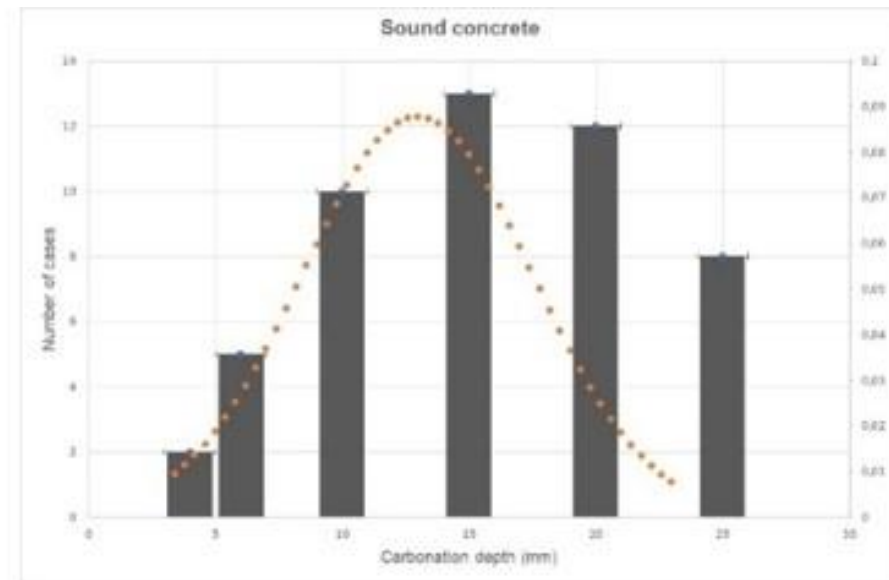
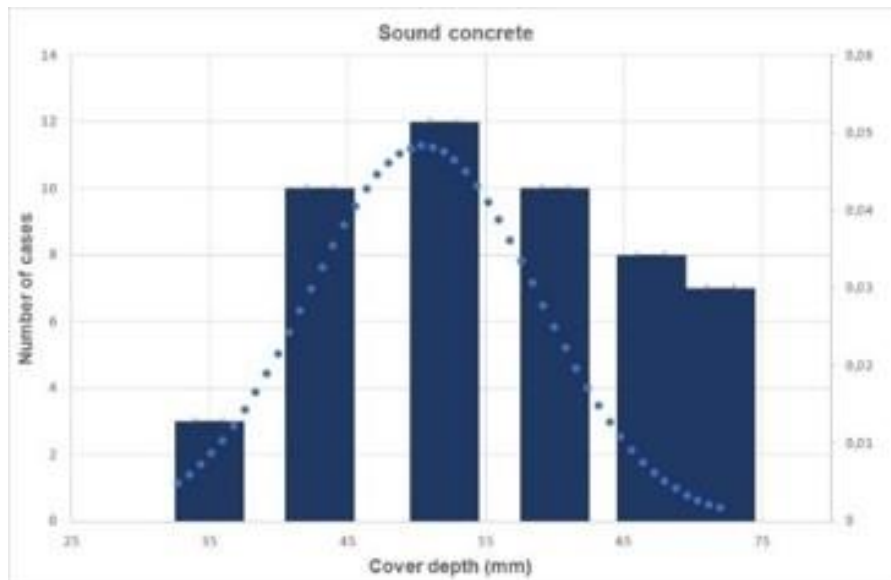

Distribution of cover depth and carbonization depth for sound concrete

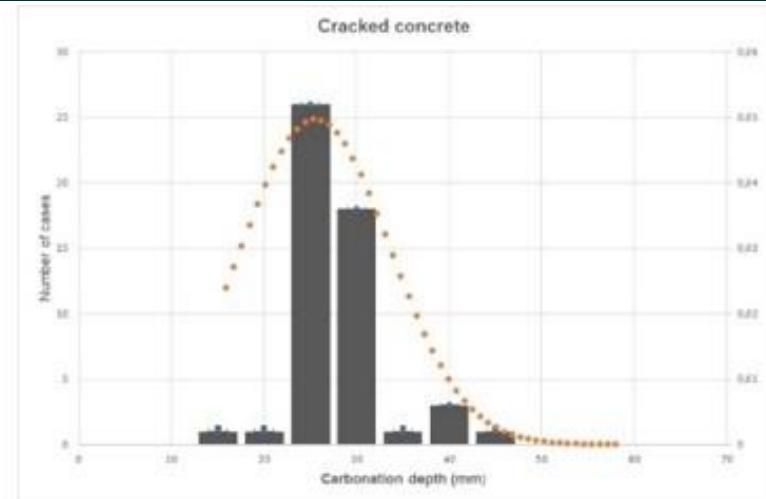
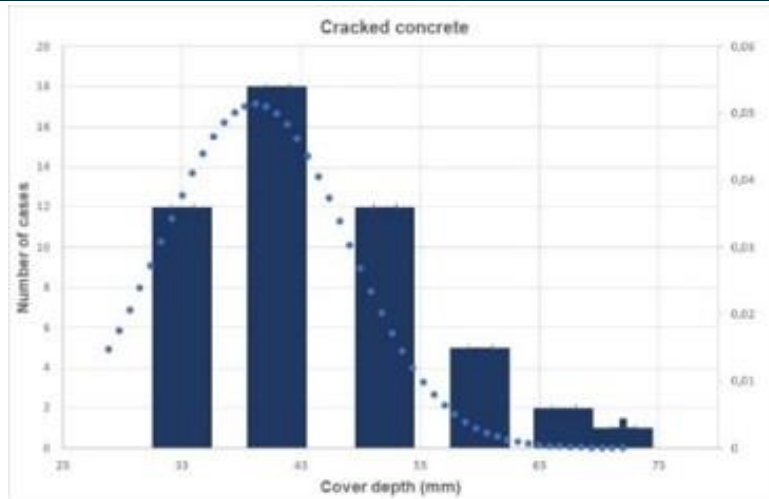

### Distribution of cover depth and carbonization depth for cracked concrete

- MEAN concrete cover depth was in the range from **32 to 72 mm**.
  - **SOUND CONCRETE:** 50.5 mm, a standard deviation of 8.26
  - **CRACKED CONCRETE:** 41.1 mm, the standard deviation of 7.77
- MEAN CARBONIZATION DEPTH:
  - **SOUND CONCRETE:** 12.98 mm with standard deviation of 4.54
  - **CRACKED CONCRETE:** 25.6 with standard deviation of 8.02
- MEAN carbonization rate (mm/year<sup>0.5</sup>):
  - **sound concrete** amounted to 3.18 mm/year<sup>0.5</sup> with the standard deviation of 0.62
  - **cracked concrete** the value was 7.23 with a standard deviation of 0.81.

- Obtained values **for durability resistance**:
  - for sound concrete **0.854**
  - for cracked concrete **0.828**
- the environmental load factor
  - for sound concrete was **1.125**
  - for cracked concrete **1.005**
- safety factor
  - for sound concrete of **1.32**
  - for cracked concrete **1.12**

## dependency of the concrete cover and service life

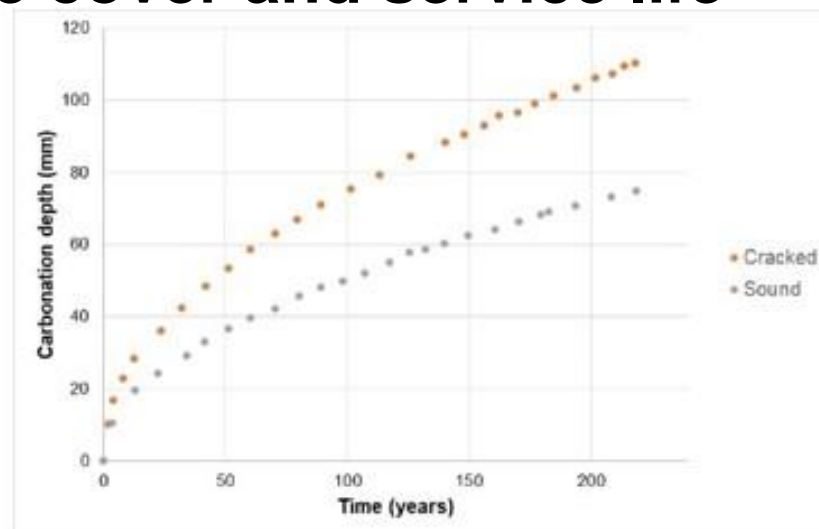
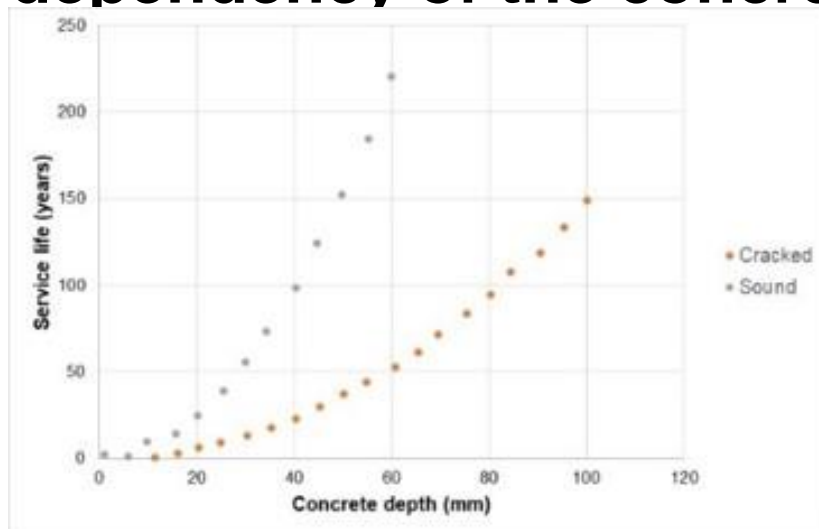

- service life is longer for the sound concrete
- **50 mm concrete cover** for sound concrete the service life would be around **120 years**, while for the cracked it would be only **41 years**
- For **cracked** concrete the service life would be only **32 years** while for the **sound concrete 98 years** for the corresponding mean measured carbonation depth

# Conclusion

- **Carbonization** as a **performance indicator** was analyzed and its connection to the **concrete cover depth** and the **quality of concrete** was investigated.
- **The quality of concrete** was an influencing element on the carbonation depth. **Sound concrete** was less exposed in respect to the cracked as expected.
- **Service life** for the sound concrete was **three times longer** in respect to the cracked concrete.
- The structure is being further deteriorated due to soft water corrosion combined with general acid corrosion .
- The structure can be classified into the damage class **D**, requesting **urgent repair and reconstruction**.



**TU1406**  
COST ACTION

**THANK YOU FOR YOUR ATTENTION**



# BRIDGE MONITORING WITH HARMONIC EXCITATION AND PRINCIPAL COMPONENT ANALYSIS

Viet Ha Nguyen<sup>1</sup>, Jean-Claude Golinval<sup>2</sup>, Stefan Maas<sup>1</sup>

<sup>1</sup>University of Luxembourg, Luxembourg

<sup>2</sup>University of Liege, Belgium



UNIVERSITÉ DU LUXEMBOURG  
Research Unit in Engineering  
Sciences (RUES)



# Principal Component Analysis - PCA

Observation matrix:  $m$  vibrational signals sampled in  $N$  times  $\mathbf{X}(t) = \begin{bmatrix} x_1(t) \\ \dots \\ x_m(t) \end{bmatrix}$

Singular Value Decomposition (SVD)  $\mathbf{X} = \mathbf{U} \mathbf{S} \mathbf{V}^T$

Proper orthogonal modes (POMs)

proper orthogonal values (POVs)

eigenmodes

*in specific conditions, e.g.*

undamped, unforced linear system, mass matrix  $\sim \mathbf{I}$ ,  $N$  is large enough



# PCA for responses to harmonic excitation

$$\mathbf{M} \ddot{\mathbf{x}} + \mathbf{C} \dot{\mathbf{x}} + \mathbf{K} \mathbf{x} = \mathbf{F} \sin(\omega t)$$

$$\mathbf{e}_s = [\sin(\omega t_1) \quad \dots \quad \sin(\omega t_N)]^T$$

$\mathbf{H}$ : frequency response functions (FRFs)

$$\mathbf{e}_c = [\cos(\omega t_1) \quad \dots \quad \cos(\omega t_N)]^T$$

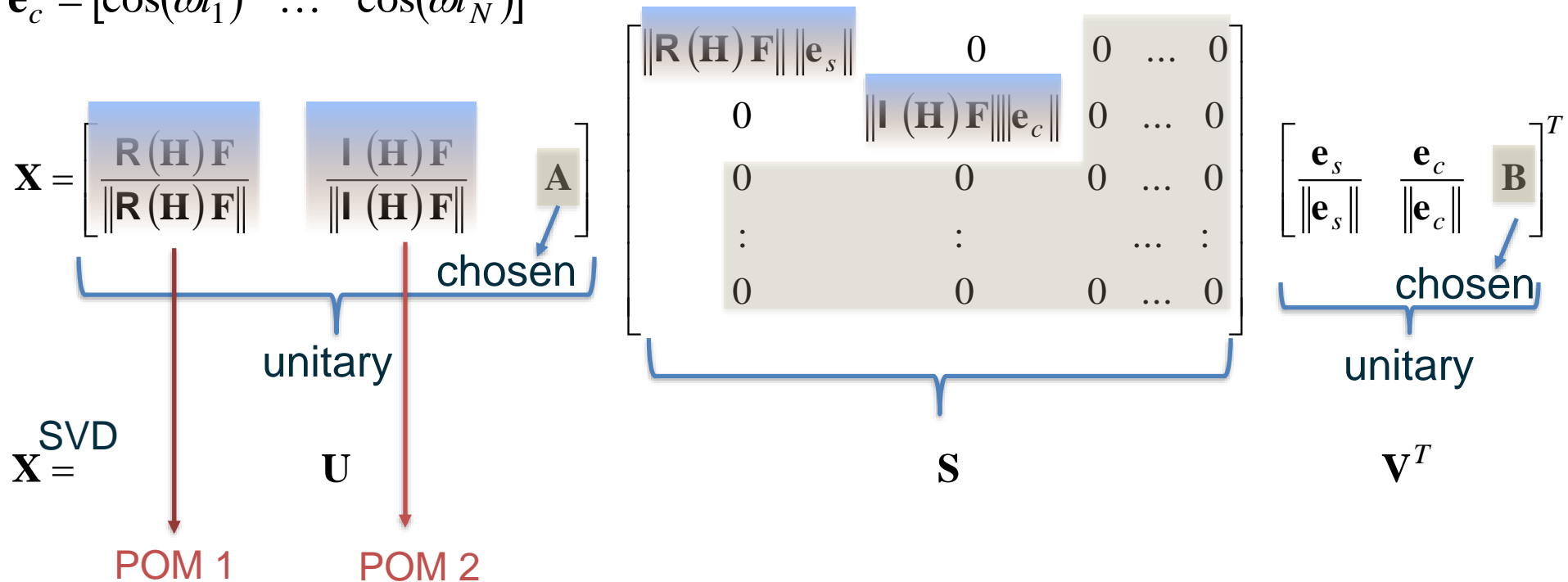

combination of all eigenmodes

$\omega \approx$  eigenfreq.  $\rightarrow$  POM  $\approx$  eigenmode

# Damage index based on subspace angle

QR factorization  $\rightarrow$  orthonormal bases  $\mathbf{Q}_O$  and  $\mathbf{Q}_D$

$$\mathbf{Q}_O^T \mathbf{Q}_D = \mathbf{U}_{OD} \mathbf{\Sigma}_{OD} \mathbf{V}_{OD}^T$$

$$\mathbf{\Sigma}_{OD} = \text{diag}(\cos(\varphi_i)), \quad i = 1, \dots, q$$

$\varphi$ : largest angle

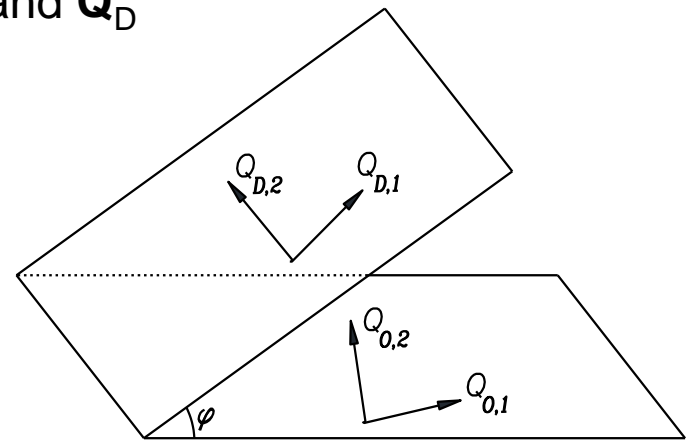

# Application

forced harmonic exciters  
controlled excitation forces



Amplitudes  $> 10$  kN,  $f > 4$  Hz



Ampl.  $< 2.7$  kN,  $f > 2$  Hz



distribution of the tendons into the beam

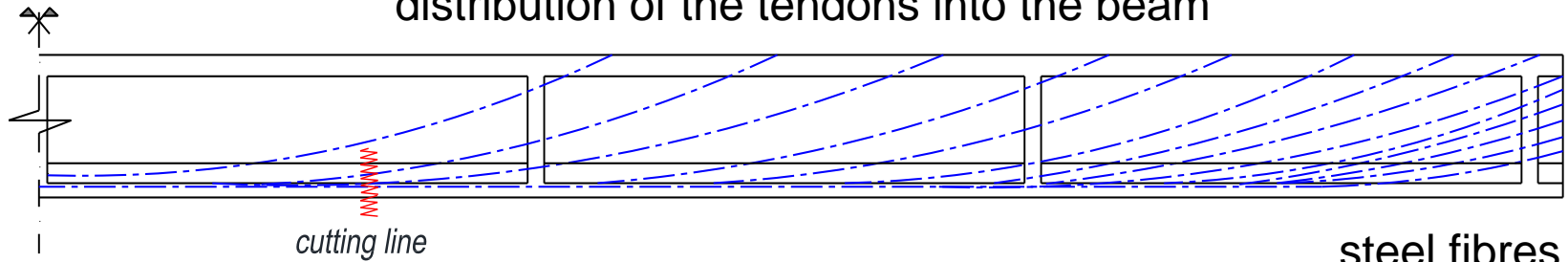

Cross section of the beam

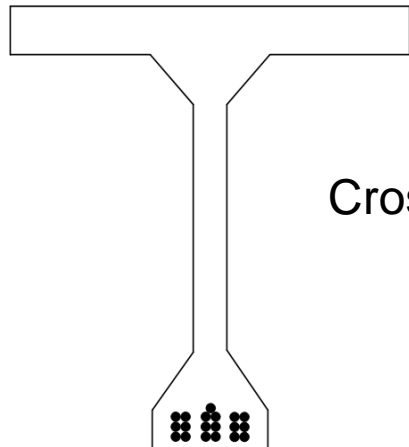

Cross section of some tendons

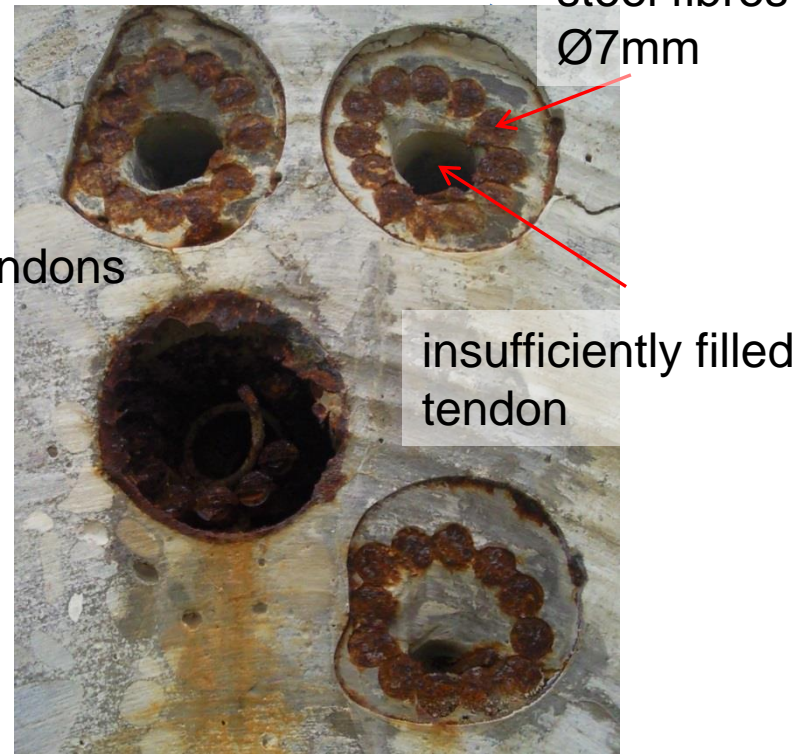

Damage scenarios

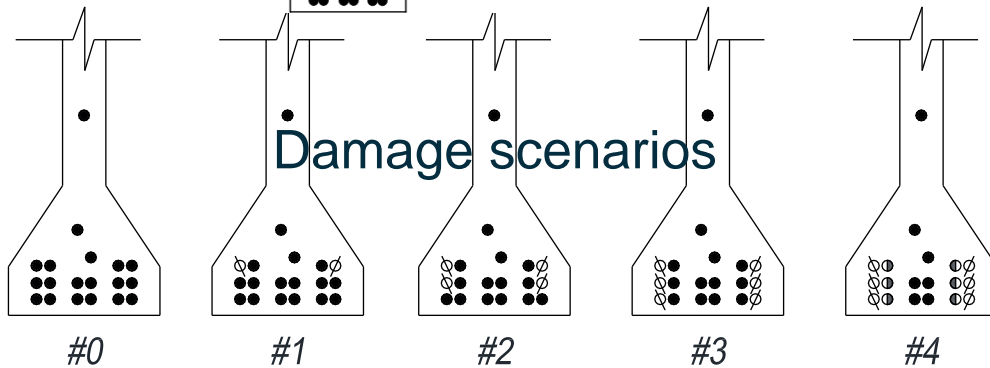

## Static tests

L & UL: Loading & Unloading;  
 #*i*: dynamic test within damage *i*



## Dynamic tests

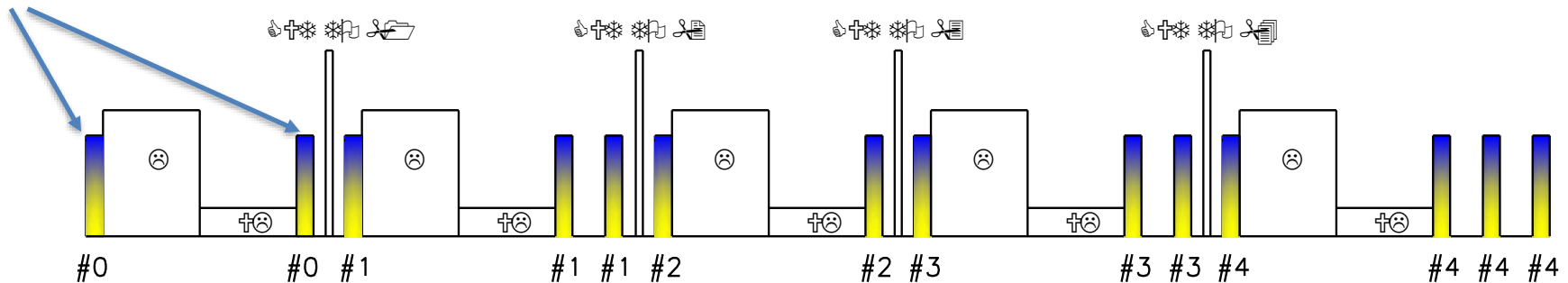

swept sine excitations, amplitude of 2000N

$f$ : 2.5Hz ÷ 25Hz, rate  $\Delta f = 0.02\text{Hz/s}$ .

Responses sampled at  $\Delta t = 0.0004\text{s}$

→ Response of 2500 samplings:  $f$   max. 0.02Hz →  $\approx$  constant  $f_{excitation}$

# Results

$$\mathbf{X}(t) = \begin{bmatrix} x_1(t) \\ \dots \\ x_m(t) \end{bmatrix}$$

$$m = 11$$

$$N = 2500$$

$$f_{excitation} \approx 3\text{Hz}$$

$$POV_1 > 90\% \sum_{i=1}^{11} POV_i$$

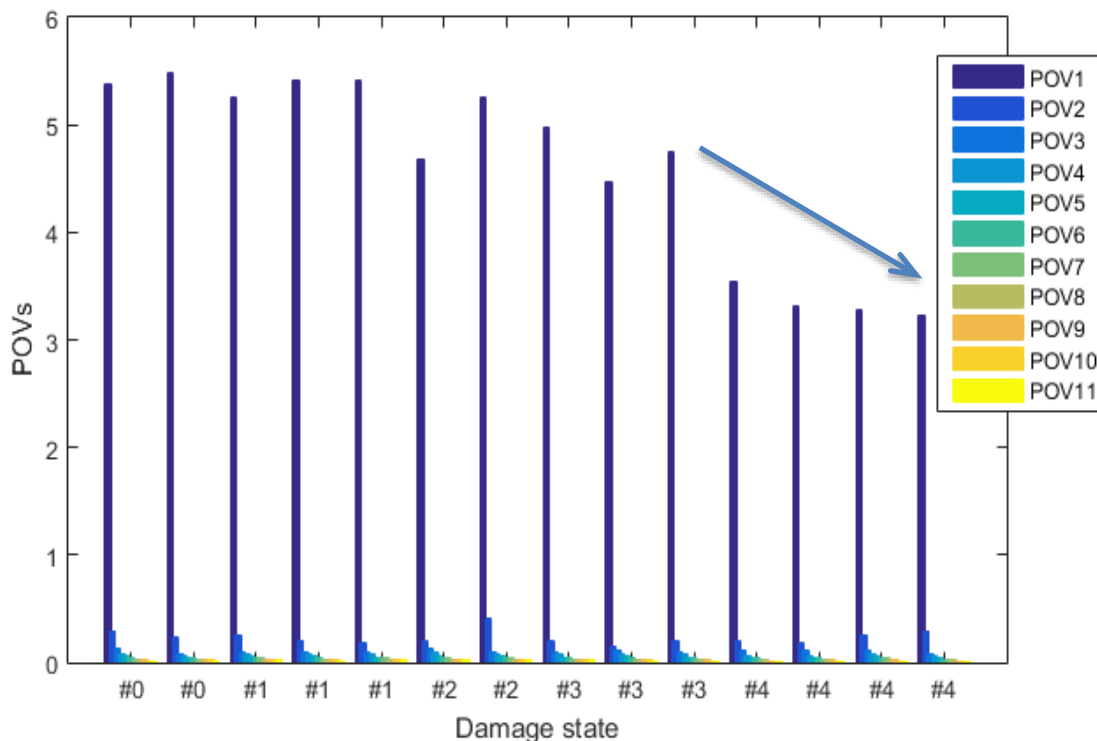
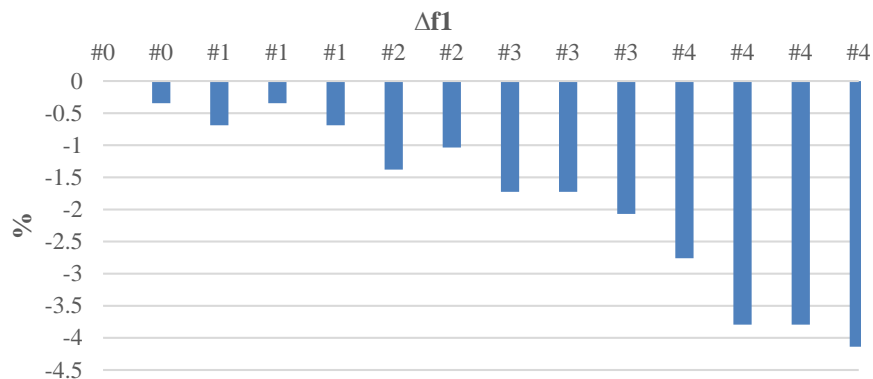

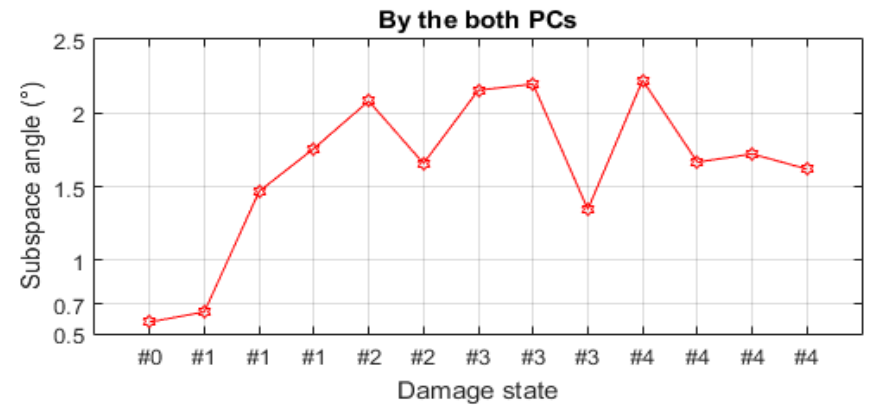
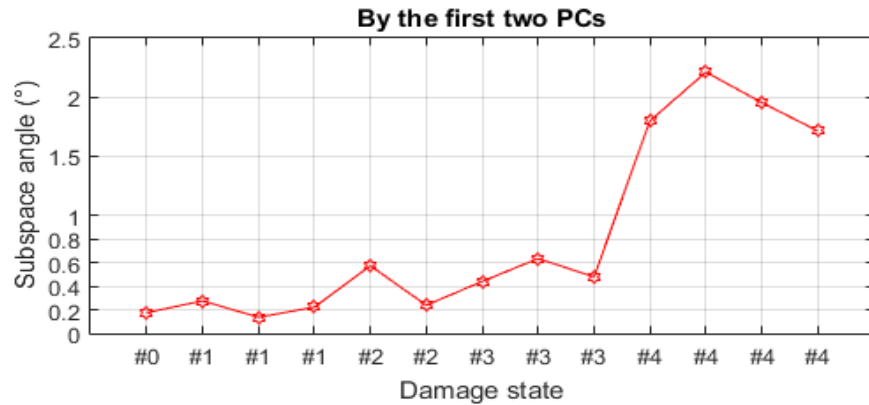
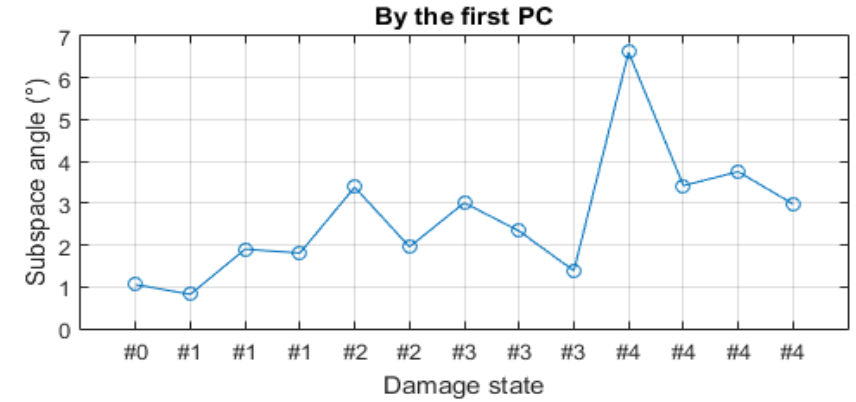
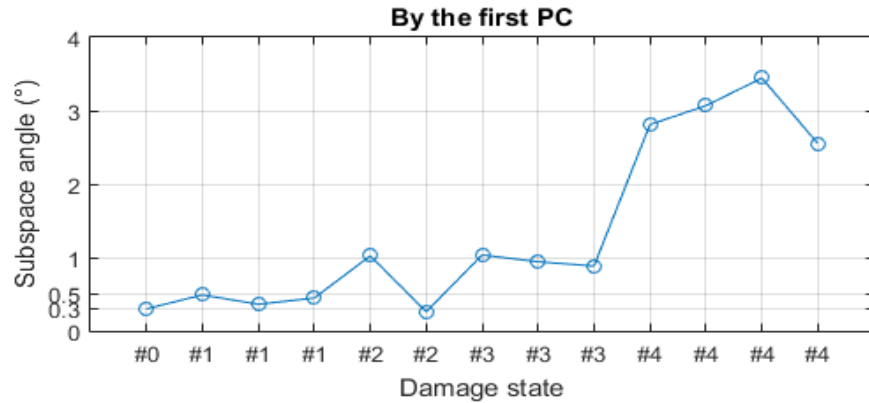

$f_{excitation} \approx 3\text{Hz near } f_1$

$f_{excitation} \approx 4.5\text{Hz near } f_2$

# Conclusions

- Vibrational responses from swept sine excitations, very low sweep rate in an operational bridge: stopping the traffic for less than a half hour
- Noise always exists, >2 non-zero POVs.

$POV_1, POV_2$  are the most dominant

$f_{excitation} \approx \text{eigenfreq.}$

→  $POV_1 > 95\% \sum_{i=1}^m POV_i$

the damage detection is more efficient





**TU1406**  
COST ACTION



# INSPECTION PROCESSES OF SUSTAINABLE SMALL BRIDGES: A CASE STUDY

**Odysseas Manoliadis** - Democritus University of Thrace

**Athina Baronou Potter** – Techn. Educational Institute of Western Macedonia

In this area you can place any logos you want.

Delete this box as it is just aimed to show the desirable limits of the logos.

# AIM

- Traditionally inspection was based on structural elements without taking into consideration inspection procedures of other bridge's components that also count in the entire lifecycle (Gervásio, 2010).
- The handbook for Sustainable Steel-Composite Bridges (SBRI, 2012) suggests strategies for inspections in a standard, lack of money and prolonged life scenario.
- Based on the above, this paper's aim is to investigate inspection processes for proper maintenance of small bridges, using as a case study the bridge of Loudias river in Greece.

# INTRODUCTION

- Greece's road network suffer different degradation processes throughout the years and, therefore, require preservation and improvement through maintenance and repair of the defects discovered during full lifecycle performance inspections.
- Such inspections integrate environmental, economic and functional aspects of all bridges components that are crucial for the sustainability of these bridges.
- Inspection as part of Lifecycle Performance is necessary for the safety and serviceability during operation, in order to provide an acceptable level, over the entire life cycle of these bridges (Jeroen, 1991).
- Inspection for Lifecycle Performance derived from sustainability strategies such as new technology and procedures. In the literature the importance of an efficient management in terms of Environmental, Social and Economic Impacts is reported as a very important factor for Highway Bridge Sustainability (Ugwu et al. 2006).

# BACKGROUND

- In the previous decade effective life cycle management studies of existing bridge infrastructure in terms of the protection of the environment, as well public safety, health, security, serviceability and life cycle cost-effectiveness was the subject of study of many researchers (Lounis 2006, Lounis and Gaigle, 2010).
- Rating systems and guidance tools were also developed for sustainable management and performance of bridges (National Cooperative Highway Research Program's "Guidebook for Sustainability Performance Measurement for Transportation Agencies", 2011, INVEST, 2012, CEEQUAL, 2014, and the Envision™, 2014).
- Application of sustainability issues, worldwide, especially for steel bridges are of essential importance. In this case, lifecycle performance calls for sustainable structures for bridges intended to cover a lifespan of more than 100 years. Maintenance processes influence at a high proportion the environment (Zingoni, 2016).
- Furthermore, resources for repair and maintenance are limited (Bridge Preservation Guide, 2011).

# Roads and Traffic Authority (RTA)

- Roads and Traffic Authority (RTA) Watson and Everett (2009) for a disciplined approach to regular inspections is an essential and basic prerequisite for sustainable effective bridge management. RTA has a comprehensive four level bridge inspection regime covering the frequency and scope of inspection and the responsibilities for conducting the inspection
  - – Time since last inspection.
  - – Risk management of known defects.
  - – Following natural disasters, floods, bushfires, and earthquakes.
  - – Strategic importance of a route or bridge.
  - – Notification from the public.
  - – Availability of special equipment and/or resources.
  - – Future live load increase.
  - – Permit Loads .

# Sustainable Steel Bridges SBRI (2012)

The objective of the produced handbook was to describe a maintenance of steel bridges including inspection procedures. In terms of inspection for sustainable effective bridge management, SBRI (2012) suggests three types of inspection as follows:

- – Routine inspection – visual observation to detect small damage that can be promptly repaired;
- – Principal inspection – detailed visual inspection with special means of access;
- – Special inspection – detailed inspection when there is a need for a specific repair plan for the complete or partial rehabilitation of the bridge.





# Loudias Bailey Bridge

The Bailey-type characteristics are the following (ThinkDefence, 2017):  
The panels dimensions are 3m x 1.5m (Length x Height) with cross braced rectangles material welded steel connecting pins. The floor consists of 5.8m width transoms, with 3.0m long stringers that form a square. Stringers are placed on top of the completed structural frame.



# Traffic Technical Inspection

Traditional inspection procedures were used for the inspection of the Loudias river bridge during its forty years operation. The cornerstone of the condition rating for Loudias River bridge was the visual inspection, which only requires that the trained bridge inspector is capable to observe the bridge elements sufficiently, Bridge has experienced significant problems that were not detectable from regular inspections and continuous monitoring. In particular, the wooden pavement had suffered very significant damage together with steel materials thus increasing the bridge's deterioration and rendering it very dangerous to cross.

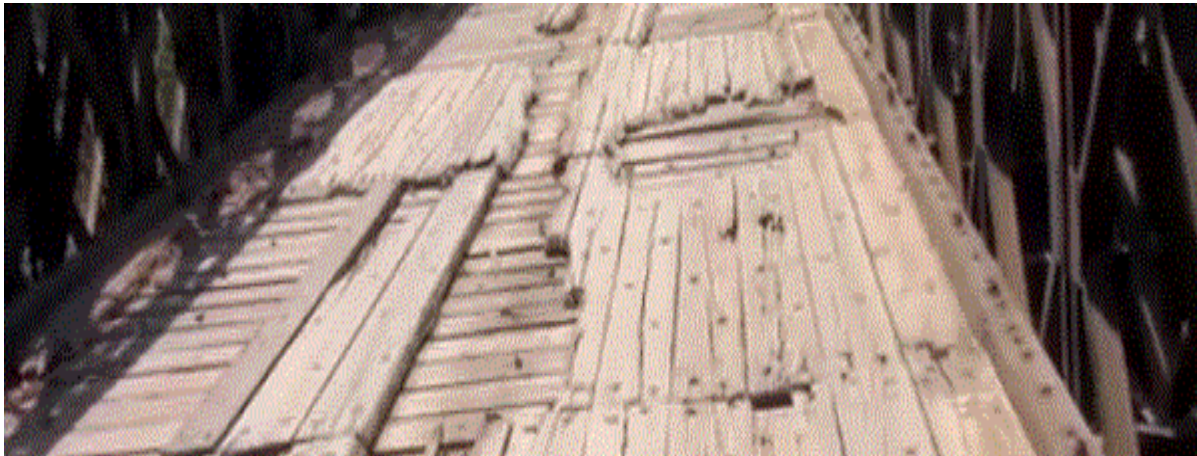

# Rehabilitation

The project's budget was EUR 58,200 and the project's schedule was six months to complete the necessary interventions, in order to obstruct as less as possible the movements of the inhabitants of the region, especially during the growing season.



# Proposed inspections

The proposed inspection procedures include regular bridge components' inspections for Loudias River Bridge that allow the monitoring of bridge condition rating and, eventually, indicate the need for various other rehabilitations actions. The proposed inspections are routine, principal, and special inspections as described in SBRI (2012), which are necessary for maintenance, repair or rehabilitation works. These inspections are:

- Routine inspection – visual observation to detect small damage that can be promptly repaired;
- Principal inspection – detailed visual inspection with special means of access. The aim is the assessment of the bridge condition rating evolution, with the definition of eventual repair / rehabilitation actions;
- Special inspection – detailed inspection when there is a need for a specific repair plan for the complete or partial rehabilitation of the bridge. Tests and laboratory analysis are also used to help evaluate damage conditions and allow recommendations for damage repairs.

# Frequency and type of inspection

Type of Inspection	Frequency
Routine	annually
Principal	6 years
Special	4 in 100 years

# Types of maintenance actions

- 
- “Standard” scenario which considers a 100-year service life, and refer to safety barrier, superstructure steel, steel corrosion protection, expansion joints, road surface, and water proofing layer.
- “Lack of money” scenario that *significantly prevents from maintenance/repair actions, thus resulting to the bridge’s critical deterioration* aiming at extending the service life of some elements. Such actions could be, for example, a partial replacement in safety barrier and expansion joints or/and minor repairs in road surface and no maintenance actions in water proofing layer.
- “Prolonged life” scenario, *which involves a decision of maintaining the bridge for an additional period of time, (e.g. 30 years more as a maximum) taken around year 80 SBRI (2012)*. After this year, inspection and maintenance actions are adapted to accomplish this service life extension

# Action for maintenance and Data recording

Action for maintenance are as follows:

- Partial replacement of safety barrier and expansion joints,
- steel corrosion protection,
- repainting of corrosion protection,
- minor repairs of road surface and no maintenance actions on water proofing layer.

# Data recording of Loudias River Bridge

Data recording of Loudias River Bridge will be conducted using data base systems, including

- deck control,
- signs,
- inspection,
- materials used, etc.

The information regarding the bridge will include data from materials to the erection of the bridge itself.

In order to improve and sustain the serviceability of bridges, data from visual inspections on a regular basis will be added forming a useful recording to check out the condition of the structure and to provide the basis for further treatment and repair operations.





**TU1406**  
COST ACTION



QUALITY SPECIFICATIONS FOR ROADWAY BRIDGES,  
STANDARDIZATION AT A EUROPEAN LEVEL  
Riga, November 23-24, 2017



## On the Potentials for Synergy Between COST Action TU1406 and the JCSS

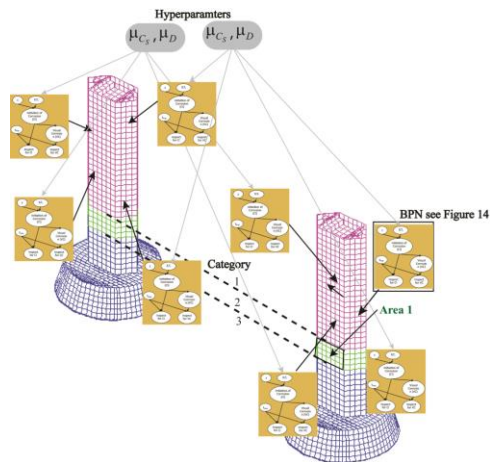
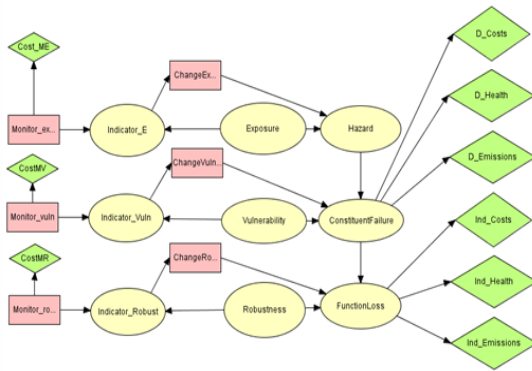

**Michael Havbro Faber**  
**Department of Civil Engineering**  
**Aalborg University, Denmark**

## **Contents of Presentation**

- **Motivation**
- **JCSS in very short**
- **Challenges of COST Action TU1406**
- **Synergies TU1406/JCSS**
- **Next steps**

## Motivation

### Objective of COST Action TU1406

Identification, classification and modelling of indicators of the performances of roadway bridges across Europe may substantially enhance the basis for their management

This will contribute significantly to safe, reliable, efficient, resilient and sustainable developments in Europe

To succeed in this quest necessitates consistent treatment of knowledge and uncertainty associated with their performances in the context of their use, environment and management

Impact necessitates pre-normative/normative dissemination

## **Motivation**

### **Objective of Joint Committee on Structural Safety**

Contribute to the general body of knowledge in the field of structural safety and to make this knowledge available to the engineering profession

## **Motivation**

### **Synergy – through win-win collaborations**

Align knowledge/perspectives

Coordinate efforts and developments

Exchange/share results

## JCSS in Very Short

### Historical perspective of the JCSS

Founded in 1971 by the Liaison Committee with the mandate to contribute to the body of knowledge in structural safety

Liaison Committee: CEB, CIB, ECCS, fib, IABSE and RILEM

Presidents:

- Ferry-Borges
- Jörg Schneider
- Ton Vrouwenvelder
- Rüdiger Rackwitz
- Michael Havbro Faber
- John Dalsgaard Sørensen
- Inger Birgitte Kroon

# JCSS in Very Short

## Activities of the JCSS

- Two meetings a year since 1971
- Issued and discussed more than 250 papers
- 30 active members/+50 passive members

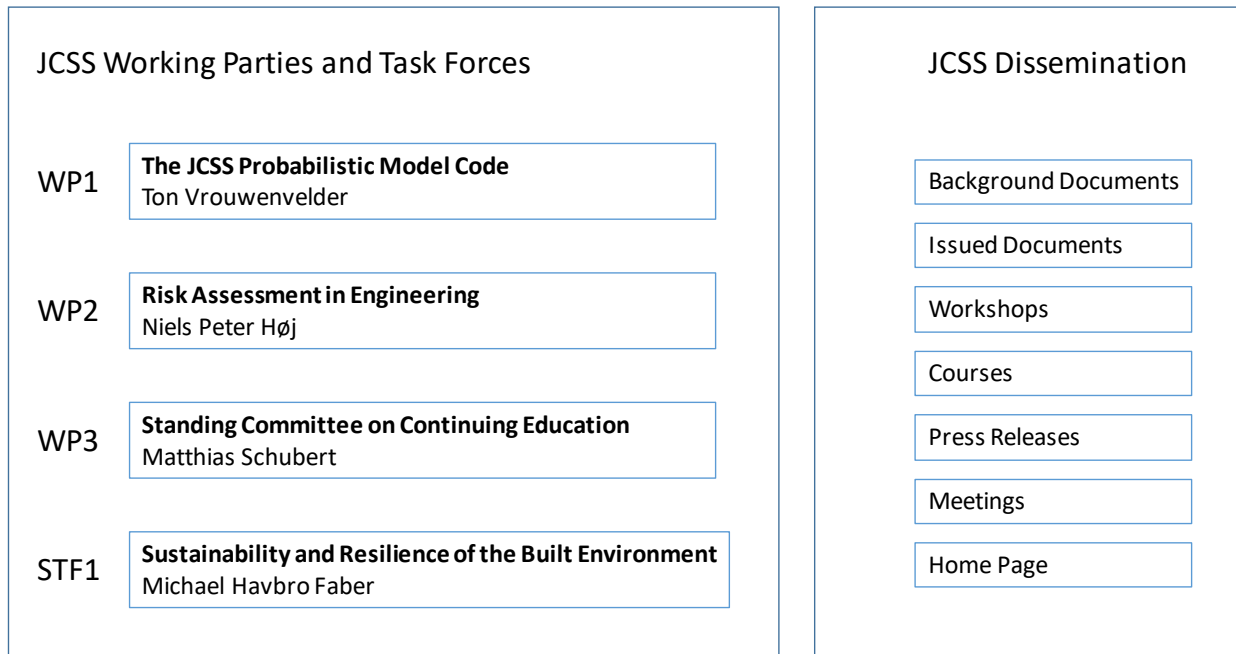



# JCSS in Very Short

## The JCSS Probabilistic Model Code

### **Basis for design**

- Basic requirements
- Reliability differentiation
- Requirements for durability
- Principles of limit state design
- Limit states and adverse states
- Limit State Function
- Design situations
- Basis of uncertainty modelling
- Basic variables
- Types of uncertainty
- Definition of populations
- Hierarchy of uncertainty models
- Models for physical behavior
- Action models
- Geometrical models
- Material models
- Mechanical models
- Model uncertainties
- Reliability measures
- Component reliability and system reliability
- Methods for reliability analysis and calculation
- Target Reliability
- Annex A: The Robustness Requirement
- Annex B: Durability
- Annex C: Reliability Analysis Principles

### **Probabilistic models for the representation of loads/actions**

- Self weight
- Live load
- Loads in car parks
- Snow loads
- Wind loads
- Thermal actions
- Wave loads
- Earthquake
- Impact load
- Fire

### **Probabilistic models for the representation of responses/resistances**

- Concrete
- Structural steel
- Reinforcement steel
- Pre-stressing steel
- Timber
- Soil properties
- Masonry
- Model uncertainties
- Dimensions
- Eccentricities
- Fatigue

# JCSS in Very Short

## Existing structures and Risk informed decision support

### Probabilistic Assessment of Existing Structures

#### PART 1 - General

##### Guidelines

- Basic concepts and definitions
- Inspection and maintenance
- Decision criteria

##### Codification aspects

- State of the art
- Requirements for codes
- Possible content of a code

#### PART 2 – Reliability updating and decision analysis

- Bayesian probabilistic reassessment of structures
- Formulation of probabilistic models
- Decision analysis in structural reassessment
- Updating techniques and software
- Posterior and predictive distributions

#### PART 3 – Acceptable and target reliabilities

- Human safety
- Calibration of target reliability to codes
- Cost benefit analysis

#### PART 4 – Acceptable and target reliabilities

- Examples
- Case studies

### Risk Assessment in Engineering - Principles, System Representation & Risk Criteria

#### FRAMEWORK FOR RISK ASSESSMENT

- Risk assessment and decision making
- Decisions and decision maker
- Attributes of decision outcomes
- Preferences among attributes - utility
- Constraints on decision making
- Feasibility and optimality

#### SYSTEM MODELING

- Knowledge and uncertainty
- System representation
- Exposures and hazards
- Consequences
- Vulnerability
- Robustness

#### RISK ASSESSMENT

- Analysis and quantification of systems risk
- Indicators of risk
- Comparison of decision alternatives
- Risk perception
- Risk treatment
- Acceptance of risk
- Sustainable discounting
- Aggregation and portfolio loss assessment
- Risk transfer
- Risk communication

# JCSS in Very Short

## Generic Indicator Based Risk Modeling Framework

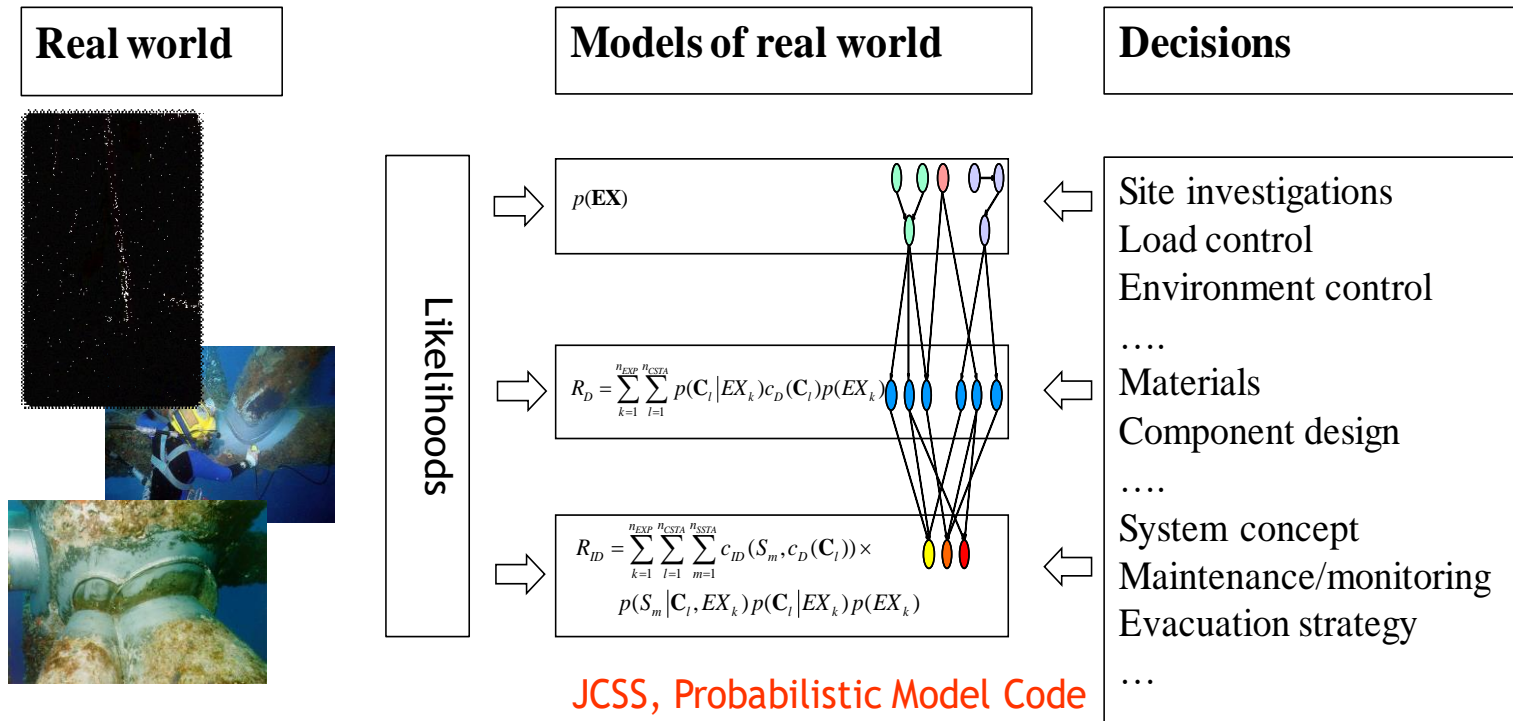

# JCSS in Very Short

## Generic Indicator Based Risk Modeling Framework

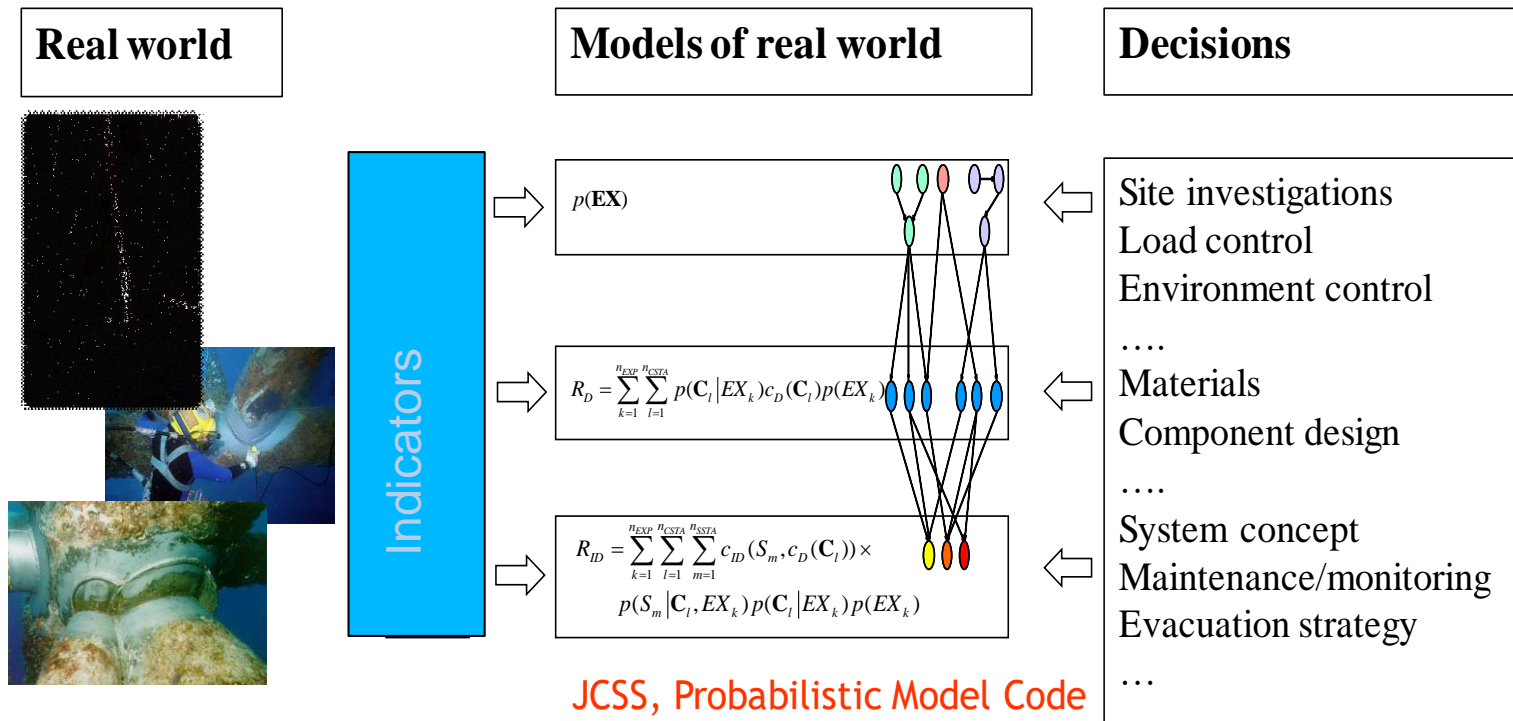

# JCSS in Very Short

## Generic Indicator Based Risk Modeling Framework

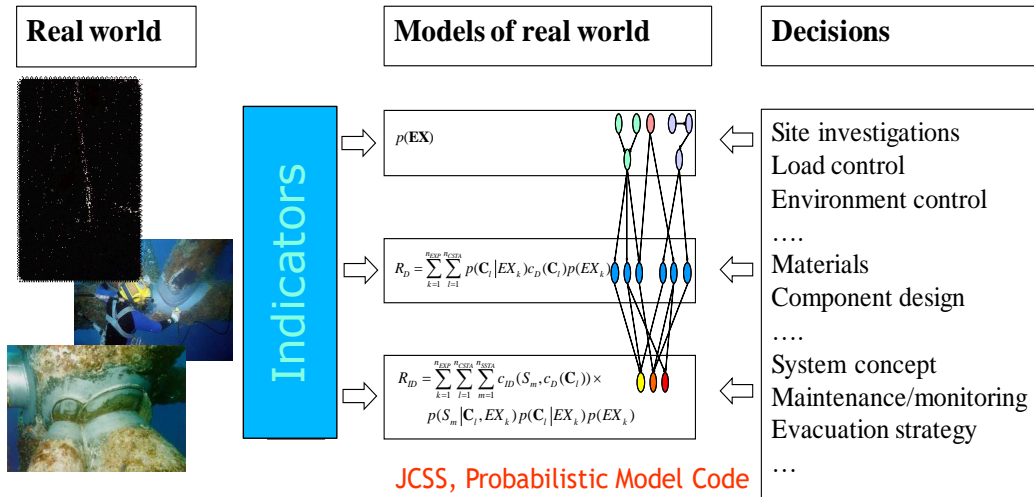

Bayes Rule:

$$P''(S_P) = P(S_P | \mathbf{z}) \propto L(\mathbf{z}) P'(S_P)$$

# Challenges of COST Action TU1406

## Indicators of the performances of roadway bridges

### Individual



### System

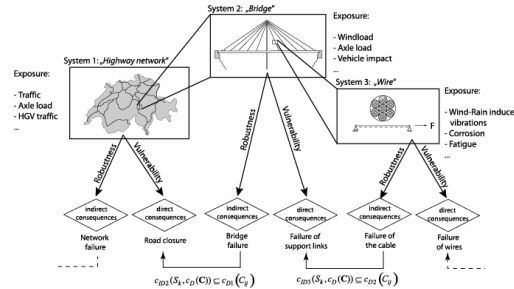

### Portfolio/asset

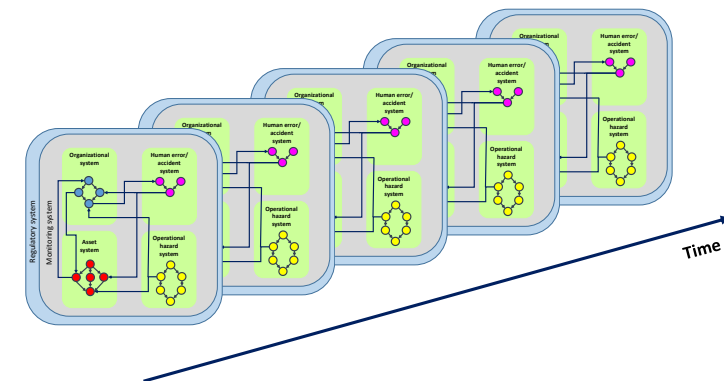
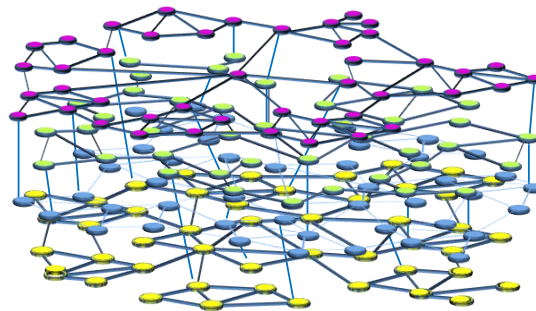
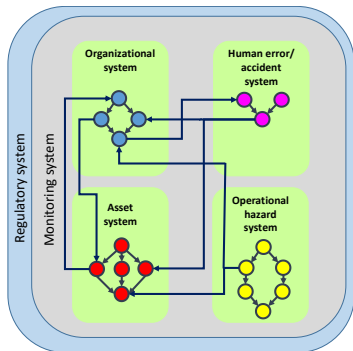
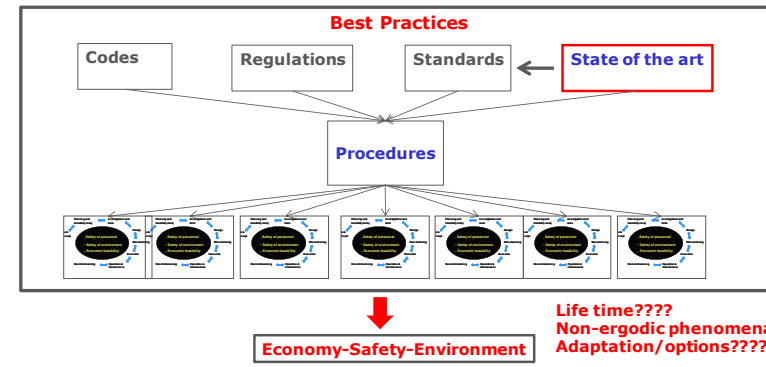

# Challenges of COST Action TU1406

## Indicators of the performances of roadway bridges

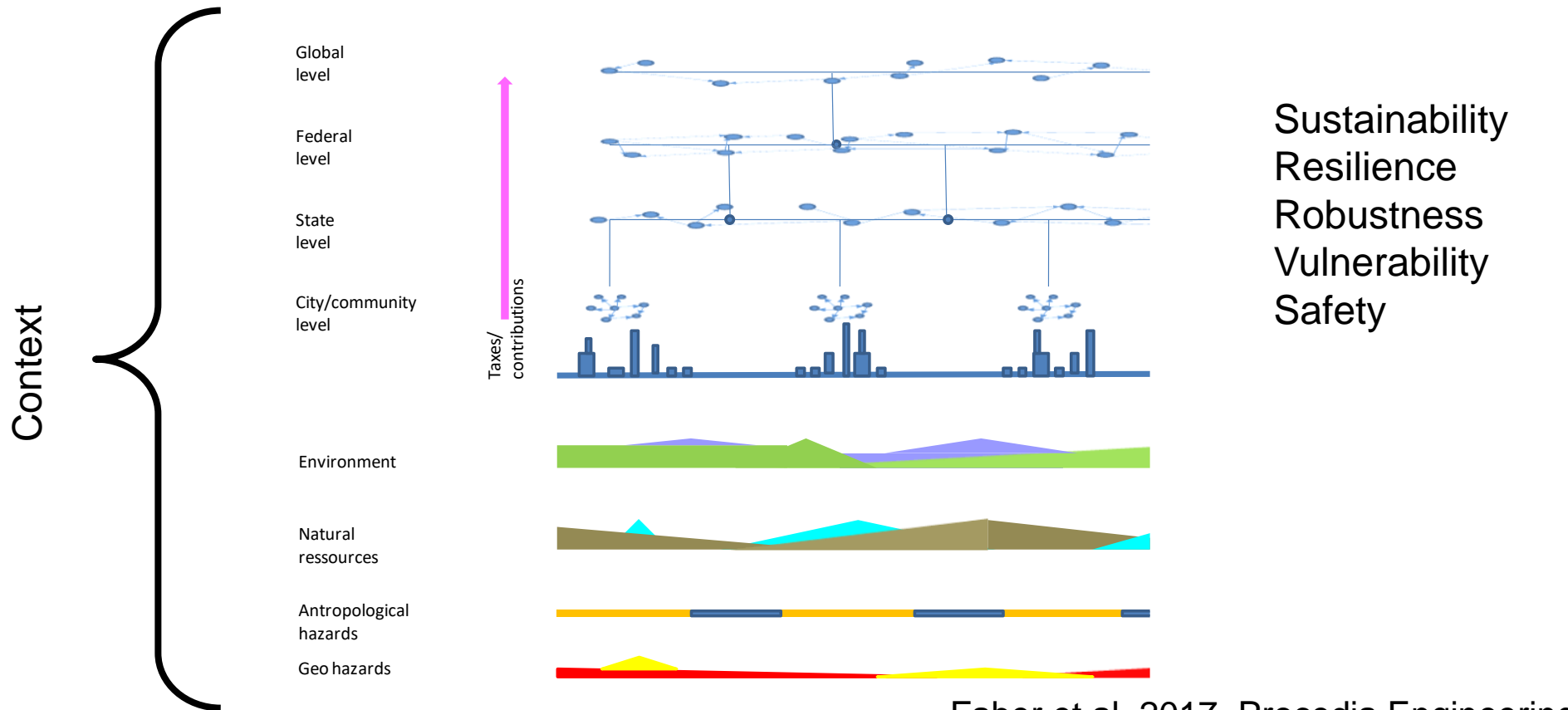

# Challenges of COST Action TU1406

## Indicators of the performances of roadway bridges

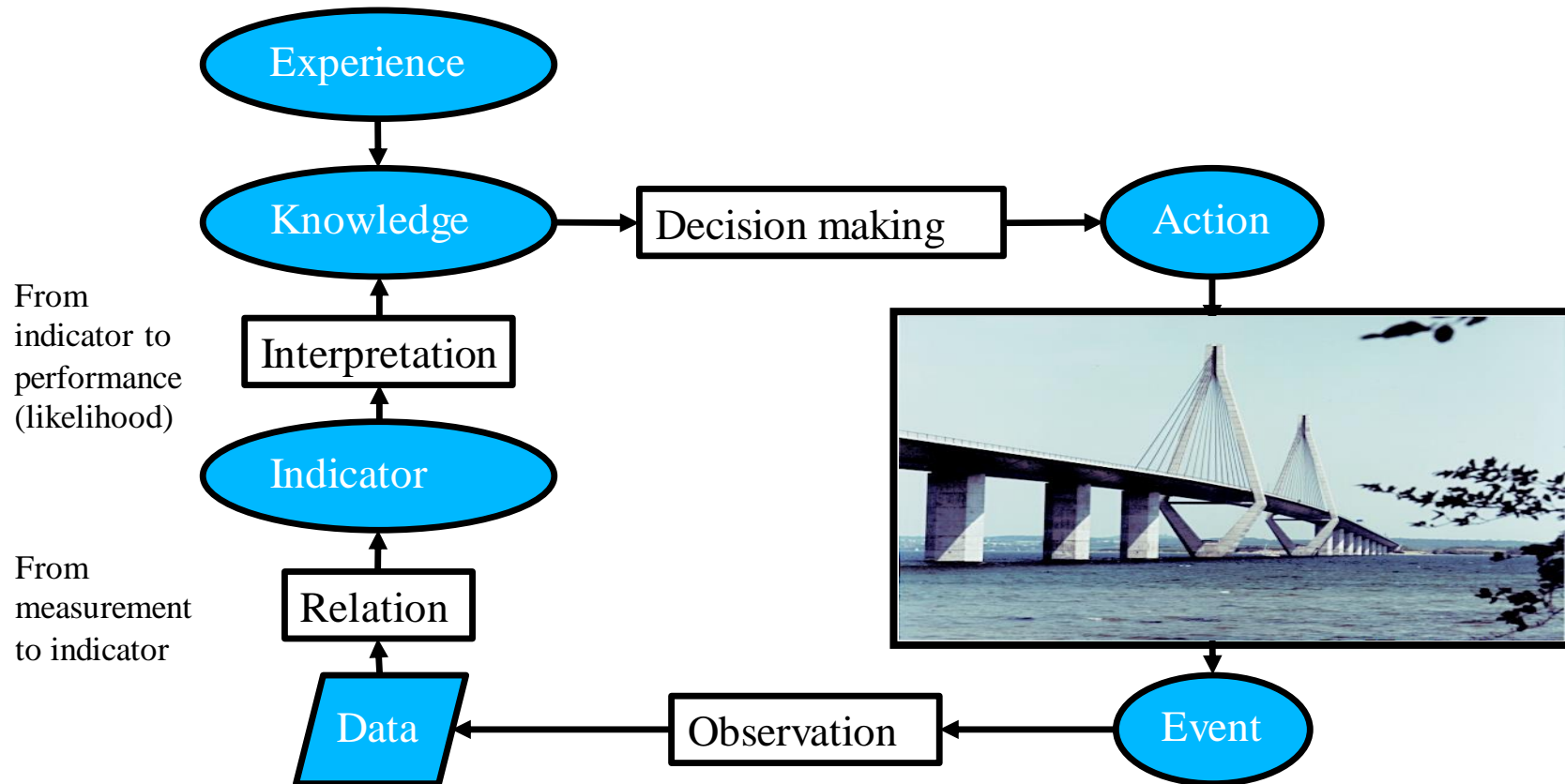



# Challenges of COST Action TU1406

## Indicators of the performances of roadway bridges

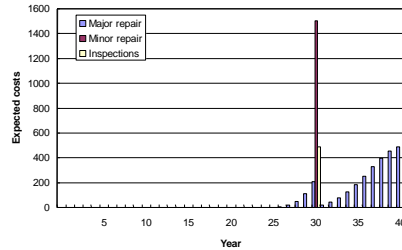
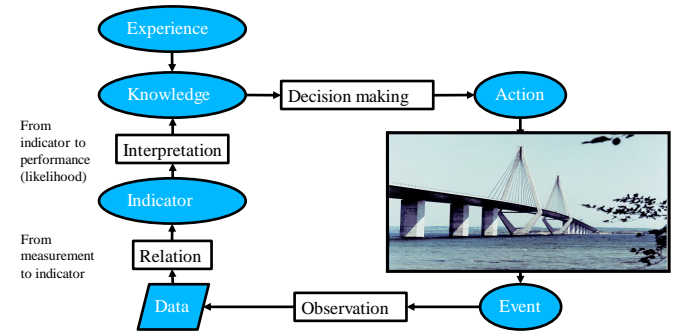
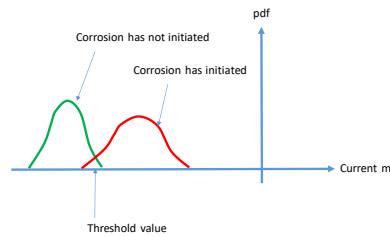
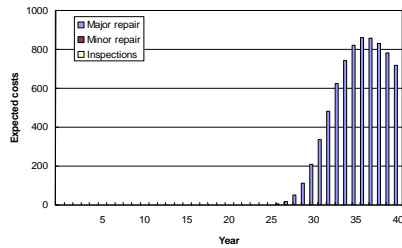

Corrosion Initiation ■  
 Visual Corrosion ■  
 Time in service = 10 years

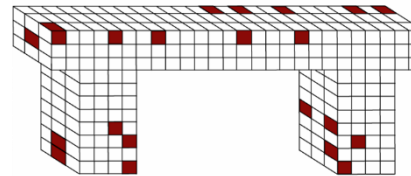

Time in service = 30 years

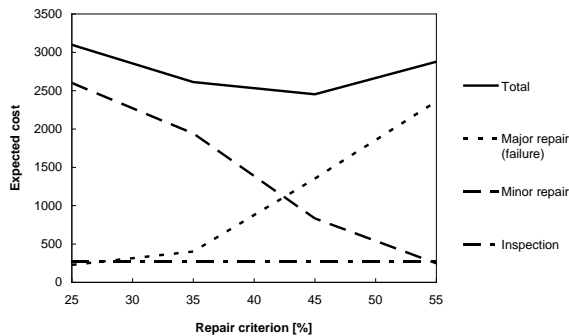
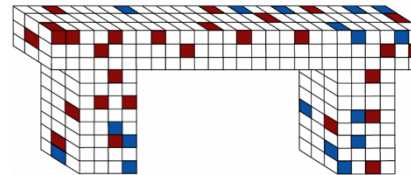

## **Synergies TU1406/JCSS**

COST Action TU1406 might take benefit from to take knowledge of the JCSS in the field of structural safety and utilize this as a platform for identifying and modeling indicators of relevance for the service life performances of roadway bridge structures

JCSS could benefit from probabilistic modeling of indicators – or equivalently – likelihoods - established within TU1406 and incorporate these in the JCSS PMC

## Next Steps

Initiate and facilitate a coordinated and targeted collaboration between COST Action TU1406 and the JCSS a joint workshop on the probabilistic modeling of condition indicators might be an appropriate vehicle

Such a workshop could also involve COST Action TU1402 – Quantifying the Value of Structural Health Monitoring.

## Literature with further references

JCSS (2001) Probabilistic Model Code. The Joint Committee on Structural Safety; 2001.  
<http://www.jcss.ethz.ch/>.

Diamantidis D. (2001) editor. Probabilistic Assessment of Existing Structures. France: JCSS, RILEM; 2001.

JCSS (2008) Risk Assessment in Engineering, Principles, System Representation and Risk Criteria. JCSS, June 2008.

Faber, M.H. and Sørensen, J. D. (2002), Indicators for inspection and maintenance planning of concrete structures, *Structural Safety*, 24, 377–96.

Faber, M. H., Straub, D. and Maes, M. (2006) A Computational Framework for Risk Assessment of RC Structures Using Indicators, *Computer-Aided Civil and Infrastructure Engineering* 21 (2006) 216–230.

Malioka V. (2009) Condition indicators for the assessment of local and spatial deterioration of concrete structures Swiss federal institute of technology. PhD thesis, Zurich.

Qin, J. and Faber, M. H. (2012), Risk Management of Large RC Structures within Spatial Information System. *Computer-Aided Civil and Infrastructure Engineering*, 27: 385–405. doi:10.1111/j.1467-8667.2012.00757.

Raiffa, H. and Schlaifer, R. (1961) *Applied Statistical Decision Theory*, Harvard University Press, Cambridge University Press, Cambridge, Mass.

Straub, D., Malioka, V. and Faber M.H. (2009) A framework for the asset integrity management of large deteriorating concrete structures, *Structure and Infrastructure Engineering, Maintenance, Management, Life-Cycle Design and Performance*. Volume 5, 2009 - Issue 3, pp 199-213.

Straub, D. (2004) Generic approaches to risk based inspection planning of steel structures. Ph.D. thesis, Institute of Structural Engineering, ETH Zurich.



QUALITY SPECIFICATIONS FOR ROADWAY BRIDGES,  
STANDARDIZATION AT A EUROPEAN LEVEL  
Riga, November 23-24, 2017



**Thanks for Your Attention!**

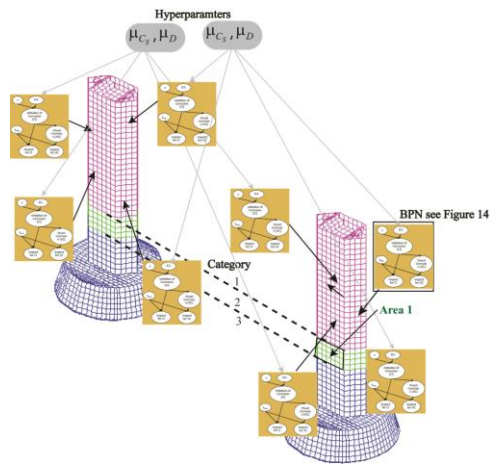
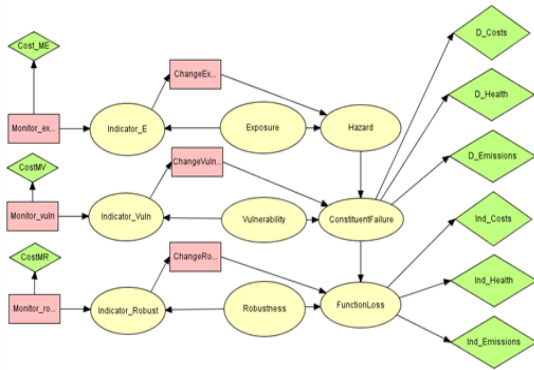

**mfn@civil.aau.dk**



# SUSTAINABILITY ASSESSMENT OF CIVIL ENGINEERING WORKS

**Antonio Burgueño**- Convenor of CEN TC350/WG6 and ISO TC59/SC17/WG5  
Sustainability in Civil Engineering Works



# SUSTAINABILITY

We want, we need to be sustainable.

Increasing demand to understand sustainable construction practices.

- by the different stakeholders involved in the construction process (administrations, private developers, citizens...)
- because their implementation improves the social, environmental and economic performances.

But...

## What does “to be sustainable” mean?

# NECESSITY

There is a need of

- A common language
- Objectivism of the subjectivity
- Being able to asses sustainability.

To asses, we need tools

- ✓ Indicator systems
- ✓ Assessment criteria





# NECESSITY

- A wide range of stakeholders has interest in the infrastructure sector.
- Moreover, they want to express the sustainability of the civil works they develop.

## NEED OF COMMON AND INTEGRATING TOOLS

- ◆ Public bodies and policy makers.
- ◆ Investor, owners, promoters and facility managers.
- ◆ Non-governmental organizations.
- ◆ Planners, developers and designers.
- ◆ Manufacturers of products.
- ◆ Contractors.
- ◆ Operators and maintainers.
- ◆ Users and people who are given service by the infrastructure.
- ◆ Nearby local residents.



# Sustainability: BUILDING Vs CEW (YEAR 2007)

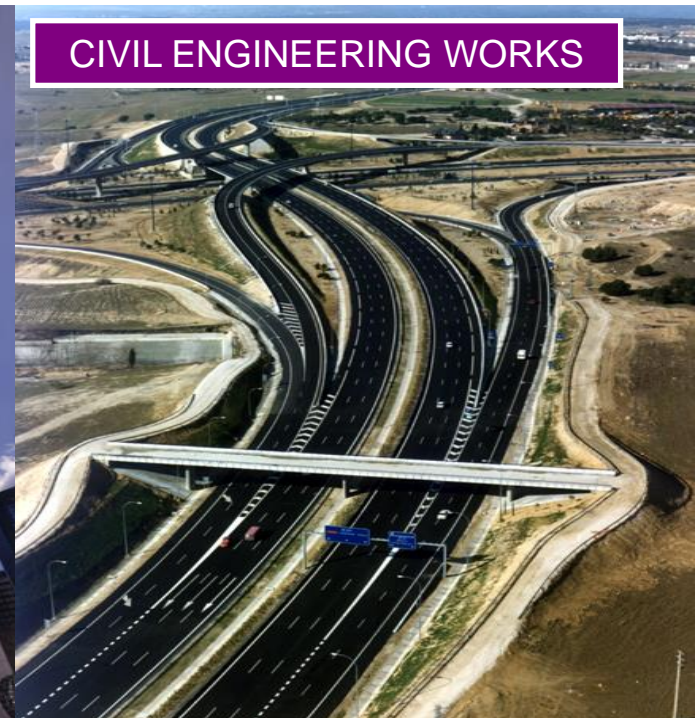
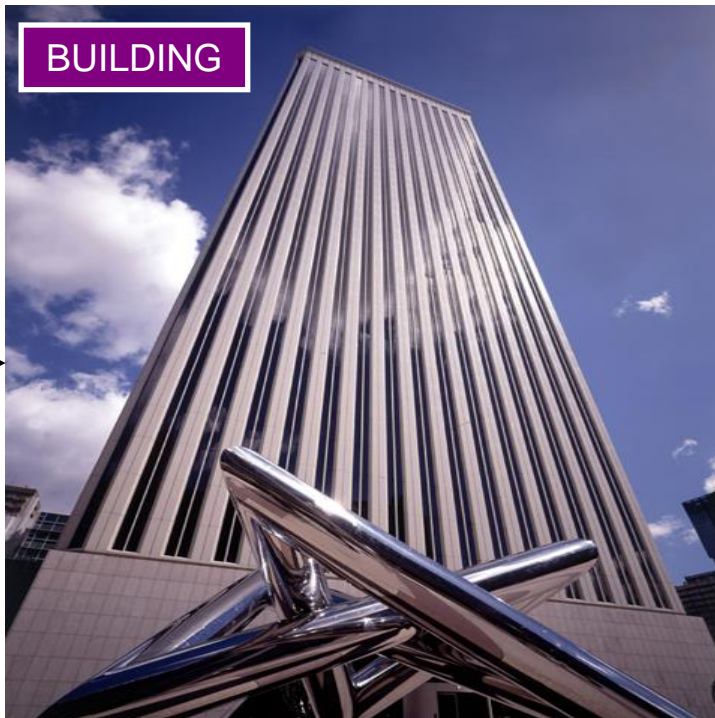

SUSTAINABILITY  
IN  
CONSTRUCTION



FOCUS!!

- Development of indicators for buildings
- Framework for methods of assessment for buildings

- ✓ immediate social perception
- ✓ space concentration

- No indicators
- Environmental Impact Assessment

- Lack of
- Social aspects
  - Economic aspects

# ISO



- ISO TC59 / SC17 Sustainability in Buildings ongoing
- July 2007: The Spanish mirror Committee AEN/CTN41/SC9 proposed to work on a new issue within ISO/TC59/SC17 dealing with civil engineering works.
- October 2007: The subcommittee ISO/TC 59/SC17 acknowledged at the 5<sup>th</sup> plenary meeting held in Seoul that **there was a need for new work to be initiated within the SC, focusing on the sustainability of civil engineering works**. It also agreed to create Working Group 5 “Civil engineering works”.
- February 2008: First WG5 Meeting held in Madrid

# CEN



- CEN/ TC 350 Sustainability in Buildings ongoing
- **November 2011:** The Spanish Proposal CEN/TC 350/N 429 was discussed during the Plenary Meeting, held on 25/11/2011 in Stockholm.
  - New Working Group (WG 6) within CEN/TC 350 including civil engineering works in the standards of this Technical Committee.
  - Taking as a basis:
    - the definitions, criteria and principles established for buildings in CEN/TC 350.
    - the work on standardisation on sustainable development for civil engineering works, undertaken by ISO/TC 59/SC 17/WG 5.
  - CEN/TC 350 members agreed to include civil engineering works in its work programme.
  - Vienna Agreement?

# EUROPE & ISO STANDARDS: SCOPE



## CEN

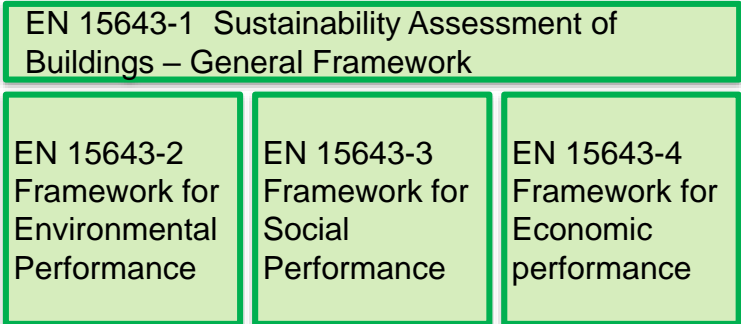

## ISO

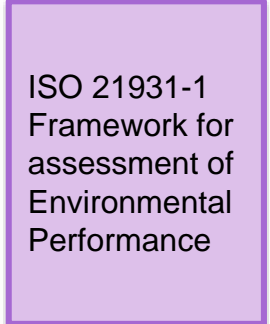

- Apply to:
- ✓ new buildings
  - ✓ existing buildings
- Include the building and the works within the building site
- Exclude aspects beyond the building site and risk assessment.



Civil engineering works: an ***unified Framework*** which encompasses the three dimensions of the sustainability in order to assess the environmental, social and economic performance of civil engineering works jointly.

# CEN SET OF STANDARDS DEVELOPED

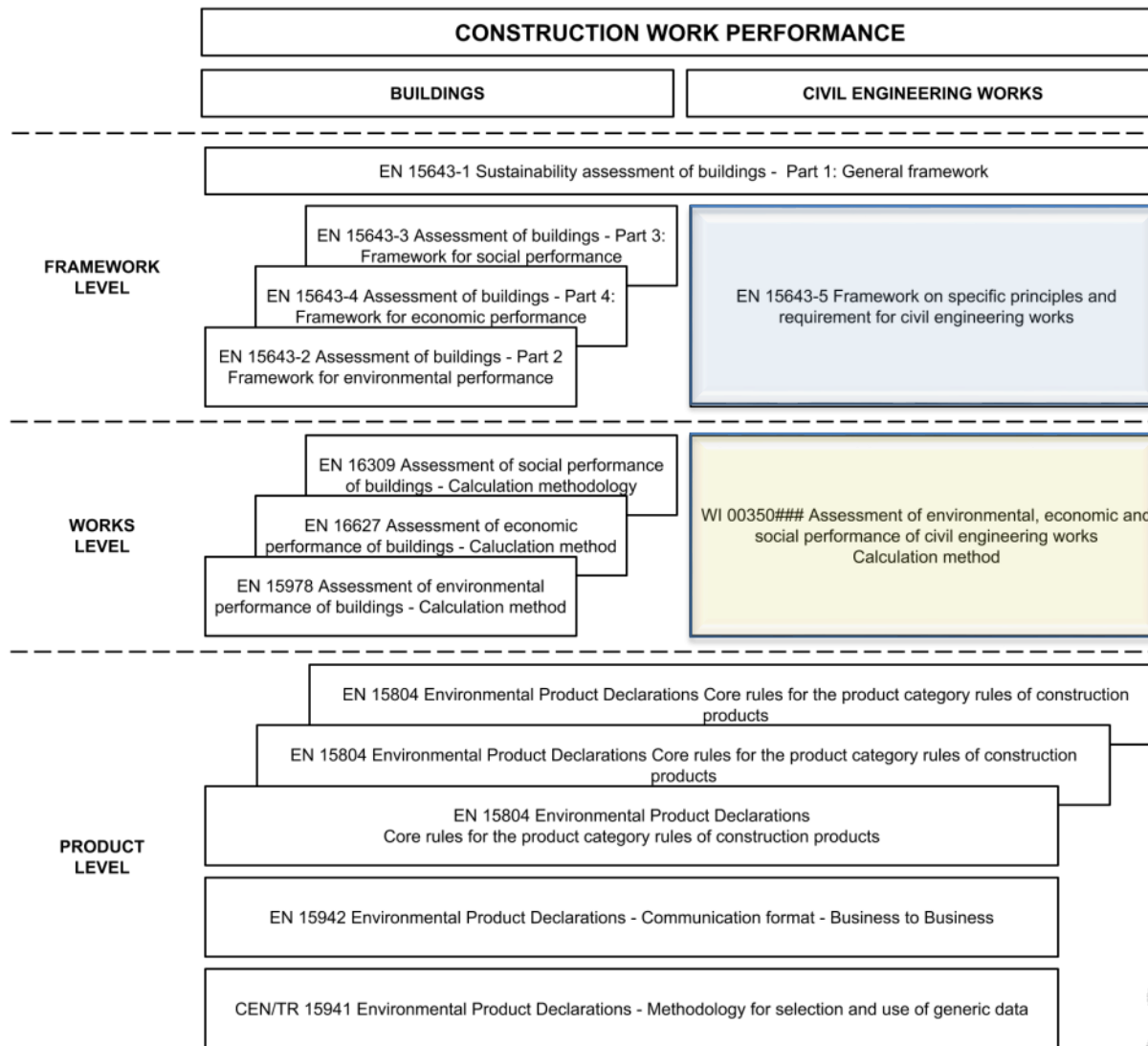

# CONTENT AND BASIS OF CEN STANDARDS

- Rules for the assessment of the sustainability of civil engineering works including **environmental, economic and social aspects**
- Technical and functional characteristics are taken into account here by reference to the **functional equivalent**, which also forms a basis for comparison of the results of assessments
- Intended to **support the decision-making process** and documentation of the assessment of the sustainability of a civil engineering work
- The method of assessment of sustainability is based on a **life cycle approach**
- The same **reference study period** is used for all three elements of the assessment



# ENVIRONMENTAL, ECONOMIC, SOCIAL PERFORMANCES

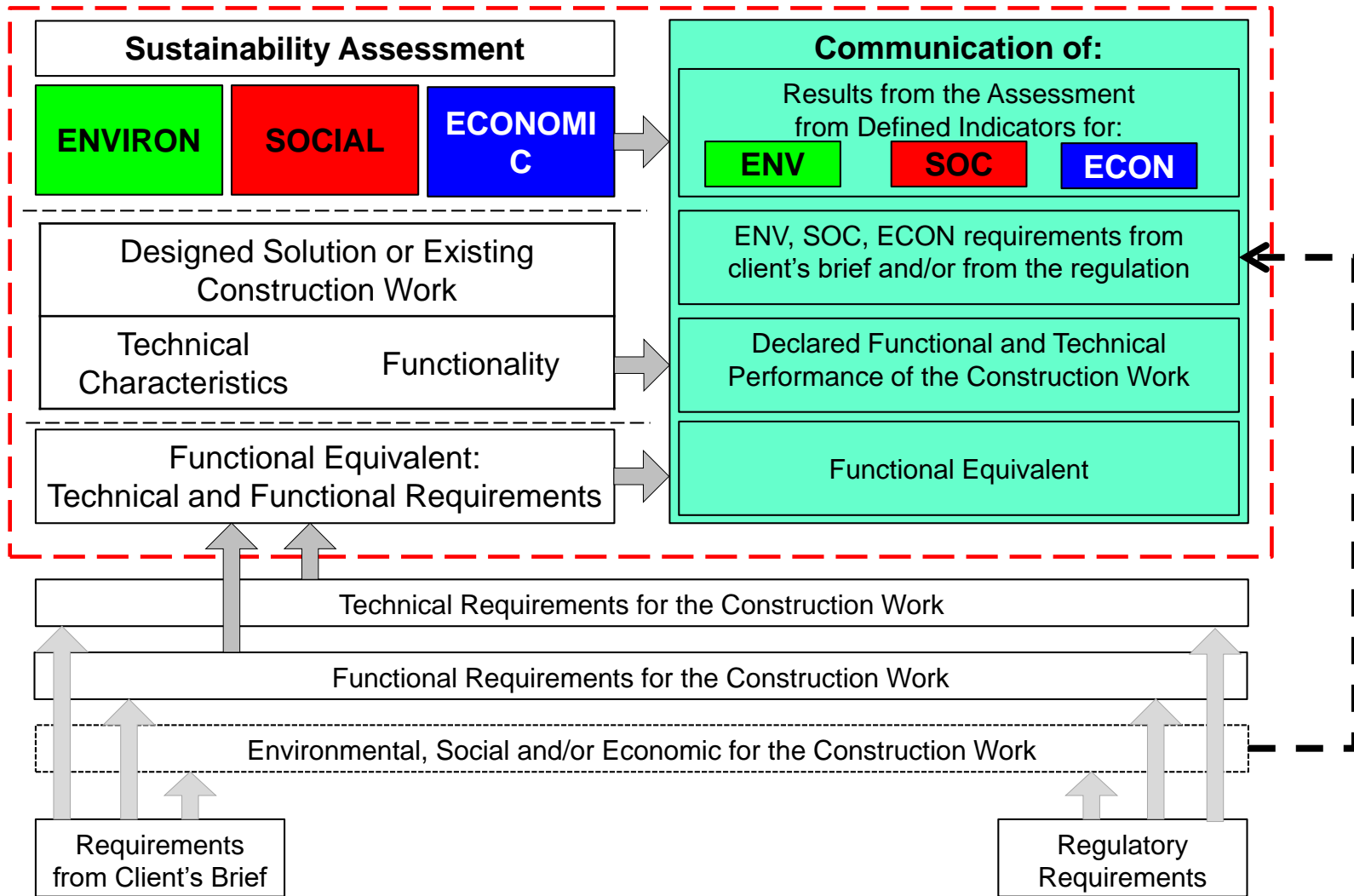



# INFORMATION MODULES

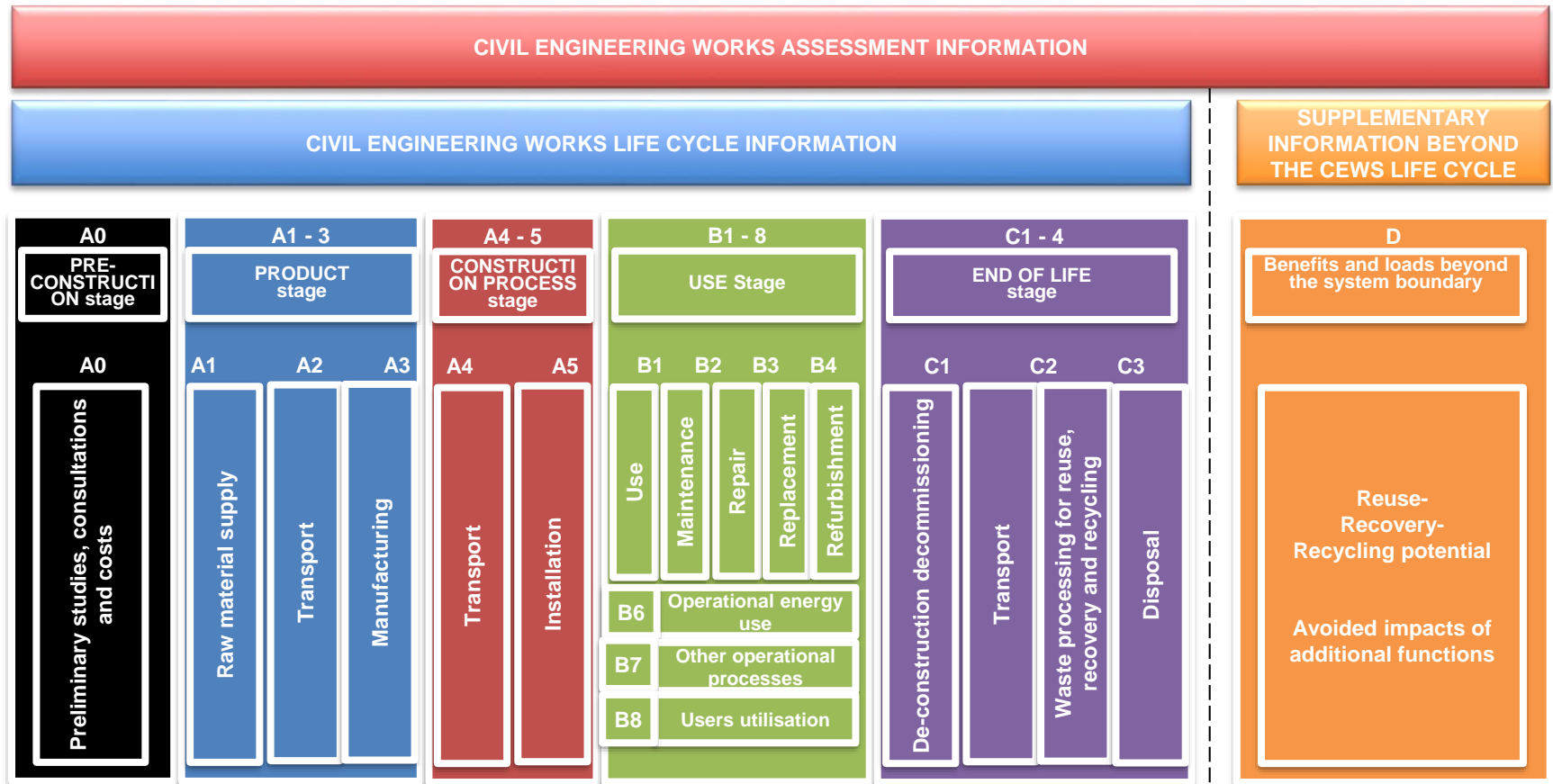

# Aspects and impacts in operation

- They start to occur **after the handover** of the civil engineering works and last **until** the beginning of the **end of life stage**.
- Aspects and impacts specific to civil engineering works asset and site in operation may come, for example, from:
  - Energy consumed for heating, pumping, lighting, operation of signage, doors or fencing, ventilation, etc.
  - Energy consumed by vehicles needed for the operation of the infrastructure
  - Use or diversion of water
  - Processes, except those related to energy consumption (e.g. salting of a road, anaerobic treatment in a water treatment plant, filling canal locks with water, etc.)



# INDICATORS

- The indicators shall be **consistent with EPD** parameters according to **EN 15804**. The assessment of sustainability performance of civil engineering works *will not include additional new indicators* in terms of product (EPD).
- To ensure transparency and a consistent flow of information:
  - The indicators should be quantitative or if not quantitative, shall be quantifiable;
  - The indicators used at the product level also shall be applicable for the civil engineering works level assessment;
  - It shall be possible to aggregate the results of individual indicators from the product level to the civil engineering works level (while still keeping the modularity principle). It should be noted that aggregation is only possible for modules identified within the "product system";
  - The indicators shall avoid double counting.



# ENVIRONMENTAL INDICATORS CATEGORIES

- Water use (quality, quantity, regulation);
- Energy use;
- Resource use (renewable and non-renewable, toxic substances);
- Waste generation;
- Pollution/Emissions to air;
- Pollution/Emissions to soil;
- Pollution/Emissions to water;
- Noise and vibration;
- Landscape (impacts such as habitat fragmentation, created values and cultural heritage, visual intrusion, recreation);
- Biodiversity (impacts such as barrier effects, mortality, disturbance, invasive species, loss of biotopes);
- Resilience including adaptation to climate change.



# SOCIAL INDICATORS CATEGORIES



- Accessibility;
- Adaptability;
- Health and comfort;
- Loadings on the surroundings; (including pedestrian and traffic disturbance);
- Noise and vibration;
- Safety / security, (including resilience against accidental actions (fire, explosion) climate change and natural occurrences such as earthquake and flooding, etc.).
- Sourcing of materials and services;
- Stakeholder involvement;
- Job creation;
- Spatial planning (including changes in population distribution);
- Protection of cultural heritage.

# ECONOMIC INDICATORS CATEGORIES

- Non construction costs
- Life cycle cost
  - Construction
  - Maintenance
  - Operation
  - Occupancy
  - End of life
- Income
- Externalities



# PROCESS OF ASSESSMENT

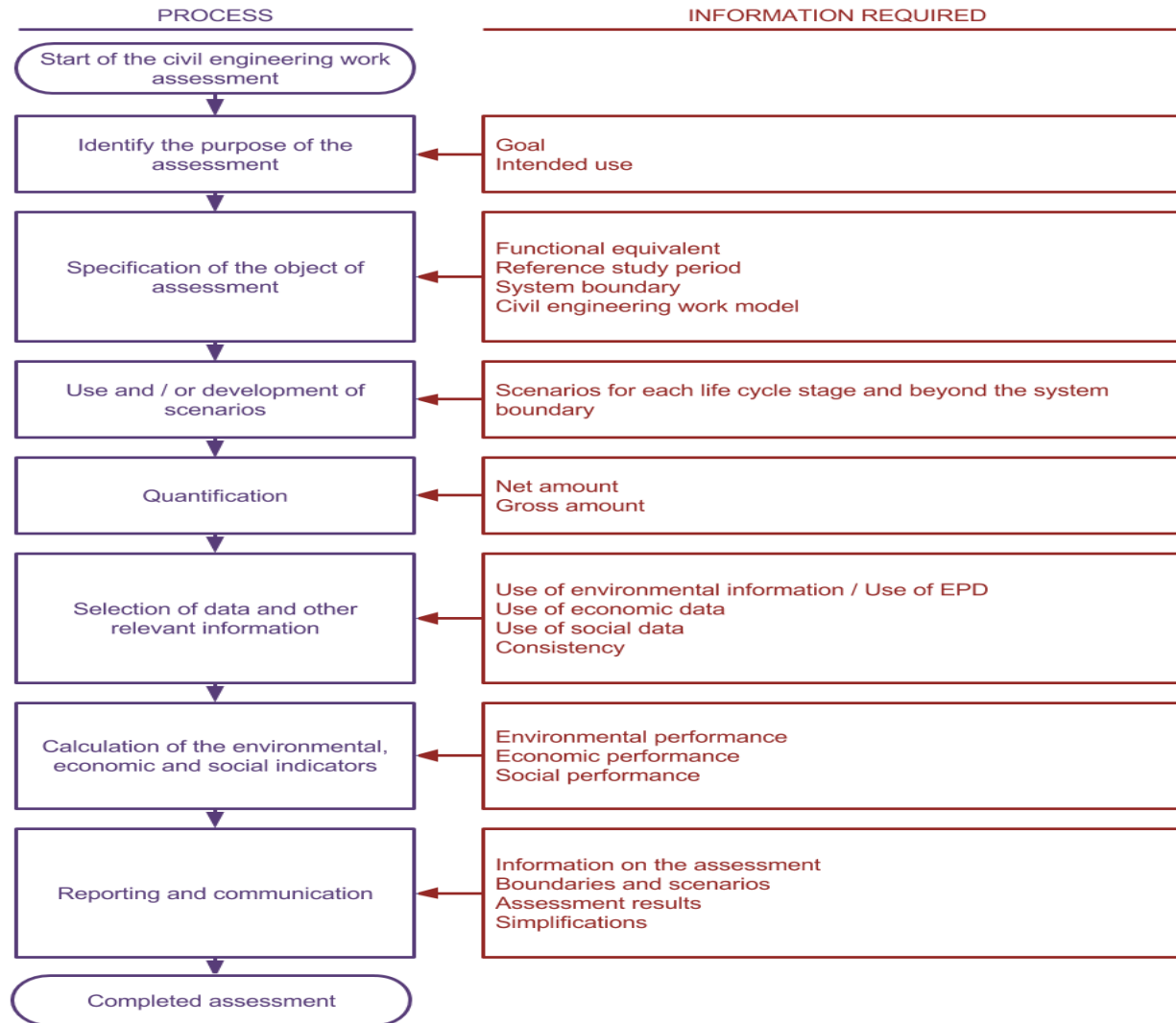

# AGREGATION LEVELS

Overall sustainability performance

Specific sustainability category performance

Impact assessment methodologies

First aggregation level

Non Aggregated primary information

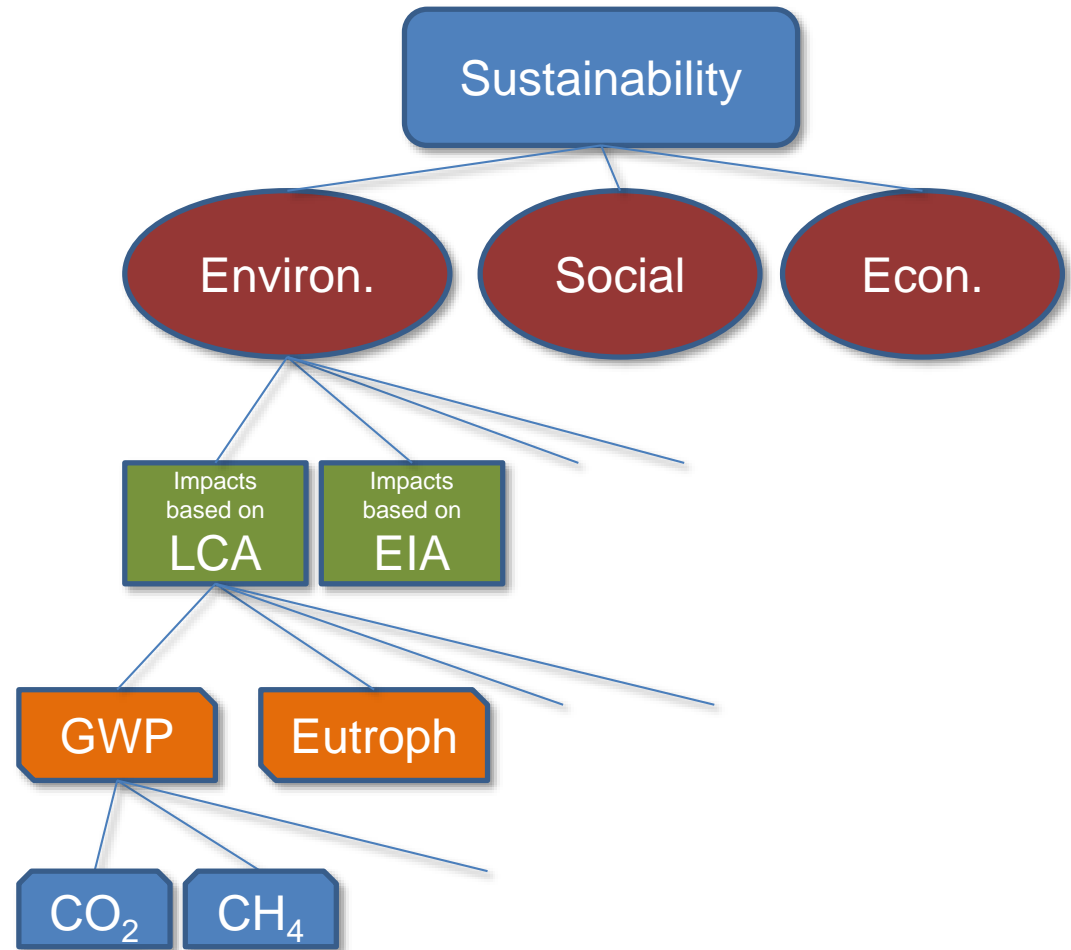



# ISO: SET OF STANDARDS DEVELOPED

	Environmental Aspects	Economic Aspects	Social Aspects
<b>Methodologic al basics</b>	ISO/DTR 21932: Terminology		
	ISO/15392:2008: General principles		
	ISO/NP TS 12720: Sustainability in building construction - Guidelines for the application of the general principles on sustainability		
	ISO/FDIS 21929-1: Sustainability Indicators - Part 1 - Framework for the development of indicators and a core set of indicators for buildings		
	<b>ISO/DIS 21929-2: Sustainability Indicators - Part 2 - Framework for the development of indicators for civil engineering works</b> <span style="float: right;">WG5</span>		
<b>Buildings or civil engineering works</b>	ISO/21931: Framework for methods of assessment of the environmental performance of construction works - Part 1 - Buildings		
	<b>ISO/DIS 21931-2 : Framework for methods of assessment of the sustainable performance of construction works - Part 2 - Civil engineering works</b> <span style="float: right;">WG5</span>		
<b>Building Products</b>	ISO/21930:2007: Environmental declaration of building products		

# CIVIL ENGINEERING WORKS TYPOLOGIES

The development and use of indicators requires the classification of civil engineering works in different typologies, such as:

- industrial process infrastructures;
- linear infrastructures (including above and below ground);
- dams and other fluvial works;
- maritime works;
- public spaces.



# CURRENT WORK

- Standardization on assessment of sustainability performance of Civil Engineering Works
- Need of indicators for each Module during life cycle

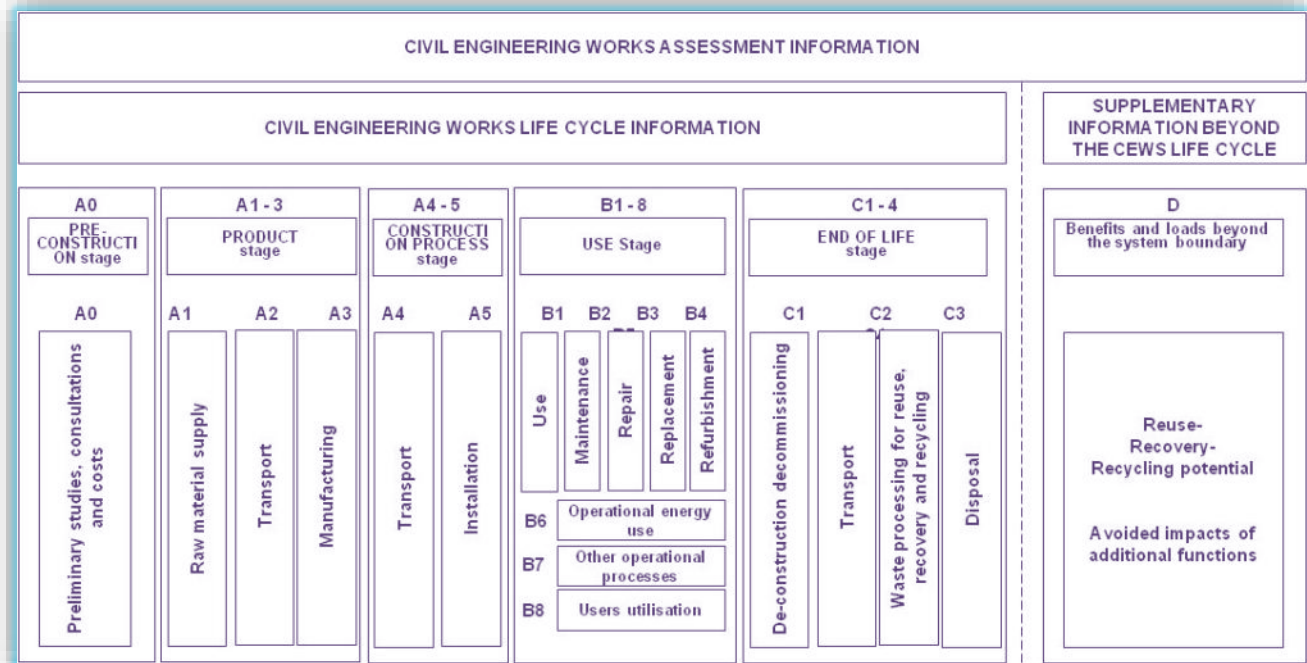

Opportunity of cooperation between COST TU 1406 and CEN/TC350/WG6 establishing performance indicators



**TU1406**  
COST ACTION



# WG3 Frame Bridge Case Study Example

**Snezana Masovic** - University of Belgrade, Serbia

**Poul Linneberg** – COWI A/S, Denmark

**Rade Hajdin** - University of Belgrade, Serbia

# Agenda

- Specificities of Girder and Frame Bridges
- Damage Processes
- Vulnerable Zones
- Observations and Performance Indicators
- **Illustrative Example**

# Specificities of Girder and Frame Bridges

- As per FP7 project SeRoN (45.896 bridges):
  - 64% are girder bridges
  - 24% are frame bridges
  - 86% are reinforced or pre-stressed concrete  $\leq$  TG2 focus



# Specificities of Girder and Frame Bridges

- Taxonomy

Group	Components ( #-presumptive number)	Primary function
Superstructure	Deck slab (1)	Load bearing
	Main girder (0 to n)	Load bearing
	Cross beam/diaphragm (0 to n1)	Load bearing
	Construction joints/Hinges (0 to n2)	Load bearing
Substructure	Abutments incl. wing walls (2)	Load bearing
	Piers (0 to k)	Load bearing
	Foundations (2 to 2+k)	Load bearing
Equipment	Bearings (0 to n·(k+2))	Articulation/load bearing
	Expansion joints (0 to j)	Articulation
	Drainage (0-1)	Protection
	Run-on slab (0 to 2)	Comfort
	Waterproofing (1)	Protection
	Pavement/Overlay (1)	Protection and comfort
	Barriers and wind screens (2 to 5)	Protection and comfort
	Signs (0 to i)	Protection and comfort
	Installations (0 to m)	Comfort



# Specificities of Girder and Frame Bridges

- Survival is a condition where the performance goal is not violated
- Survival of bridge components (based on condition rating! and discrete-time Markov chains)

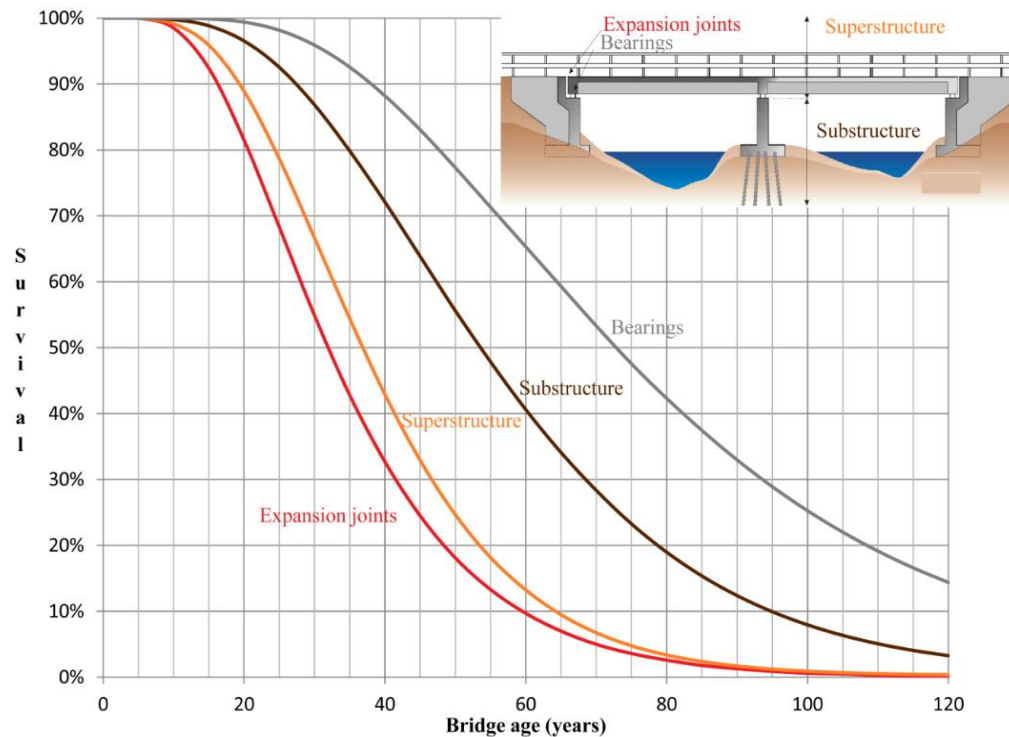

# Specificities of Girder and Frame Bridges

Most common structural systems (examples):

*Single span* (label **GA**)



*Gerber type girders* (label **GG**)



Most common superstructure cross sections (examples):

**Solid slab** (Label SA1)

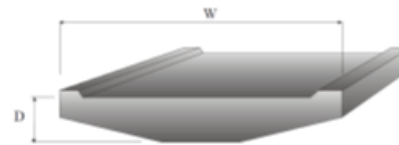

**Void slab** (Label SA2)

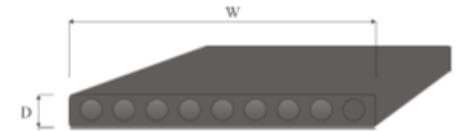

**Pseudo slab** (Label SA3)



Similar has been provided for substructure components.

Equipment is not labelled, ref. spec. literature. Instead vulnerable areas are highlighted.

# Damage Processes

27 Damage Processes identified for concrete girder and frame bridges:

N.º	Proposed Damage Processes	Material			Direct impact on KPI's
		Concrete	Steel	Masonry	
					A- Change in geometry B. Change in integrity C. Change in material properties D. Change in actions
1	Abrasion	•	•	•	A, B
2	Aggradation/alluviation	•	•	•	D
4	Water penetrability	•		•	B, C
5	Erosion	•	•	•	A, B
15	Corrosion related to reinforcement steel	•			A, B, C
16	Corrosion related to structural steel		•		A, B, C

# Damage Processes

- Quantitative modelling of bridge damages in 1D (current BMS) to 3D (future BMS based on BIM)



- Damage intensity, extend and location should be described (we made reference to Sustainable Bridges approach).

# Vulnerable Zones

- Conceptual Weaknesses (further categorization wrt. exposure to damage processes and sudden events is possible)

Gerber type beams (label **BB**)

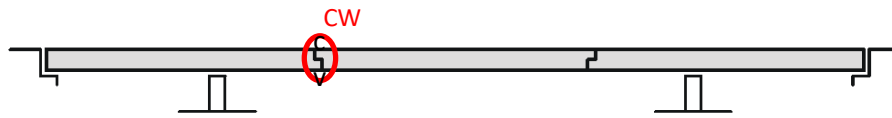

- Vulnerable Zones related to superstructure

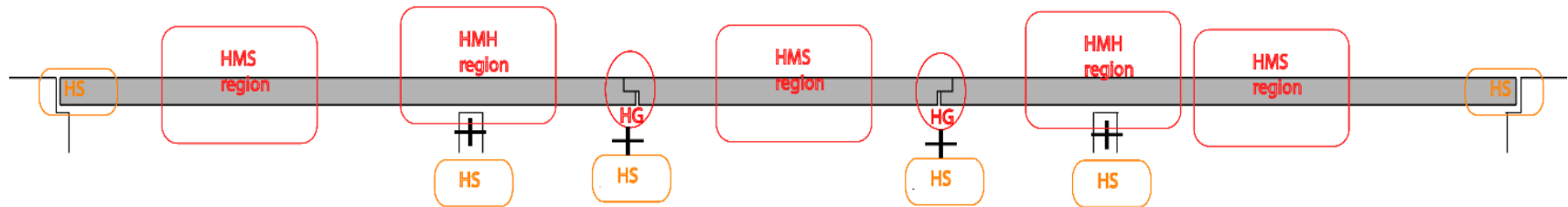

- Vulnerable Zones related to substructure and equipment is described with due reference to specialist literature.

# Hidden defects in bridges – guidance for detection and management

## CIRIA C764



- What do the records say?
- **What is not recorded?**
- What can I see?
- **What can I not see?**

# Observations

- Observation is the **active acquisition of information** from a primary source.
- Observation **can also involve the recording of data** via the use of instruments.
- Observations can be **qualitative**, i.e. only the absence or presence of a property is noted, or **quantitative** if a numerical value is attached to the observed phenomenon by counting or measuring.

# Performance Indicators (PI)

- A bridge Performance Indicator (PI), indicates the performance of the bridge. For instance, a crack width larger than 0.4 mm can indicate that the reinforcement yielded (at least ones) and can be the indicator of insufficient resistance or equally likely of one-time overloading.
- In this case, the same **observation can indicate two different outcomes regarding reliability**: one with an impact on reliability and one with no impact on reliability but on irresponsible transport company. In subsequent inspections, this dilemma can be cleared by investigating if the crack grows.
- So, there is a difference between **observations** and **PI's** as the first are **'just the fact'** and the latter **is already interpretation of its impact on performance**.
- Essentially, **PI is the quantitative or qualitative impact** of an observation on one or more performance aspects.



# Observations

WG1 Cluster	Observation – S if symptom	Damage Processes (Numbers according WG3 report)
Defects	> Bulging (expansion) - S	> 4, 6-8, 13, 15, 16, 21-23
	> Crack	> 5-10, 14-22, 24-26
	> Crushing	> 3, 8, 14, 22, 25
	> Debonding	> 3, 4, 9, 11, 13, 15, 21, 23, 25, 26
	> Delamination	> 10-13, 15, 19, 23, 26, 27
	> Efflorescence/crypto-florescence - S	> 4, 11, 13, 25
	> Holes	> 1, 4-8, 19, 23, 25, 26
	> Insufficient concrete cover	> 1, 5, 11-13, 15, 19, 21, 23
	> Rupture	> 1, 3, 5-8, 13-17, 20-25
	> Scaling – S	> 4, 5, 7, 11-13, 15, 16, 19-21, 26
	> Spalling	> 11-13, 15, 19, 26
> Wet spots - S	> 3, 4, 6, 10, 23	

- Symptoms have no direct impact on static (snapshot) KPI's (reliability and safety)
- Other clusters, ref. WG3 report

# Observations

- Observations that affect vulnerable zones are most important



# Illustrative example – introductory notes

- **Data gathering** may be performed using the guidelines of the Long-Term Bridge Performance (LTBP) Program Protocols.
- It has been decided by COST TU1406 that the **approach is qualitative**. However, the approach also has to be applicable for quantitative approaches. In a **quantitative approach** the failure scenario has to be explicitly defined and observations have to be related to the failure scenario.
- Since deterioration processes are time dependent the QCP has to **consider the date**, when observations have been made. In addition, the QCP should have **performance predictive models** associated. In this way, the infrastructure manager may plan preventive maintenance using the QCP. For concrete structures reference is made to models in e.g. fib bulletin 34 and Mainline D2.3. Discussion and comparison of stochastic prediction models based on visual inspections of bridges has been performed in referenced literature.

# Illustrative example

General appearance and location



Pavement/Overlay with curbs



Railing



Cornices



Abutment

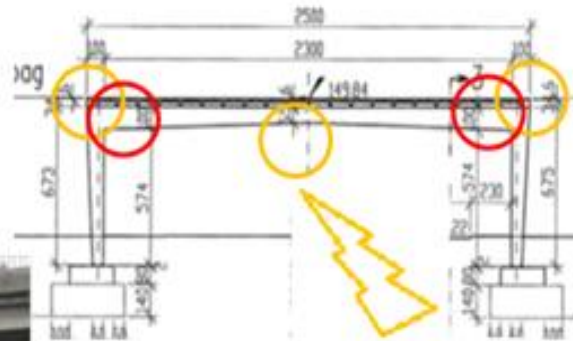

Mail girder - slab

# Illustrative example

- Consistent with current inspection practice, performance values are evaluated as a **snapshot in time**.
- The inspection should be carefully planned before visiting the site (step I). Locations of **vulnerable zones** depend on the structural system. During visual inspection those zones should be carefully examined. Orange cycles indicate zones where bending failure (ductile) is possible. Red cycles indicate zones where shear failure (brittle) is possible. This colour indicates that the red zones are more critical.
- Information regarding **previous inspections and/or interventions** is very important, especially if those are located in vulnerable zones. If the damages were repaired, current inspection would reveal the **effectiveness of the repair measure**, and if not, the **speed of the damage process** might be estimated.

# Illustrative example

Structural type - FA

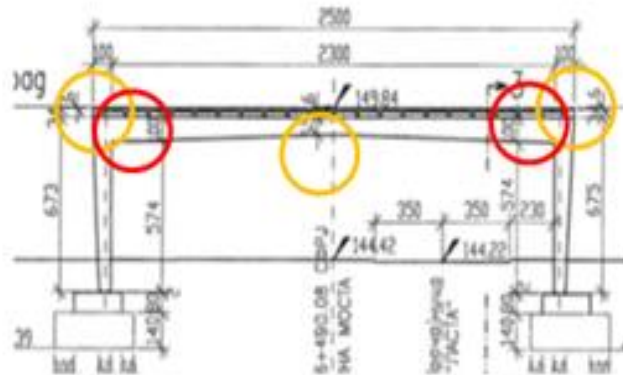

**Vulnerable zones**

**High moment region - ductile**

**High shear region - brittle**

Cross section - SA1

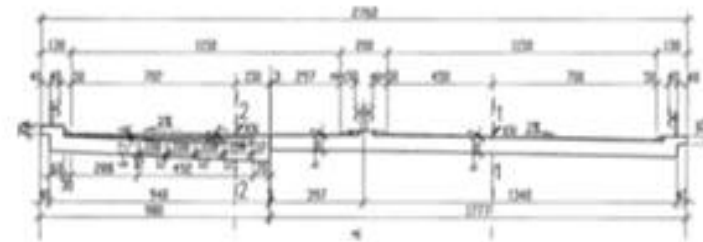

Abutment - AB1

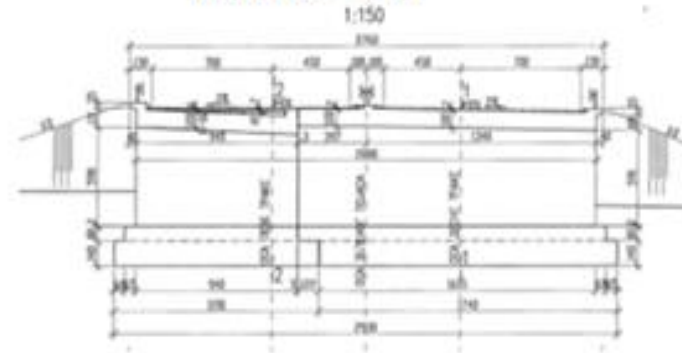

# Illustrative example

## Step I – Preparation for the inspection (desk work):

### 1. Inventory information:

- RC frame bridge;
- Original blueprints available
- Construction year 1963;
  - No particular weaknesses of original design;
  - No particular material weaknesses are known – steel bars didn't have any ductility problems
- Widened in 1977;
  - The obvious weakness is the longitudinal joint connecting the old and the new parts of bridge
  - The bridge was recalculated in 1977;
  - The bridge was designed according to the previous Code of practice (no information concerning prior reliability index);

# Illustrative example

## 2. Inventory information (cont.):

- Compare the current traffic load to traffic load model used for previous calculation;
- Estimate prior “virgin” reliability index (it was estimated as 3.8 for this example) – maybe estimate from old design load. Design failure scenarios should be revisited during inspection (any change).

## 3. Other relevant information:

- Estimated current traffic on the bridge (AADT is 10,000);
- A local road passes beneath the bridge (uncertain AADT on the local road);
- No particular natural hazard;
- Location is city periphery;
- Climate is continental;



# Illustrative example

## 4. Previous inspection/intervention:

- 2001. Condition rating – fair (intervention was suggested);
- 2008. Condition rating – poor (intervention was suggested);
- 2014. Condition rating – serious (load rating was suggested);
- No data available concerning previous intervention

## **Step II – On site inspection (ref. also next slides):**

1. Study of previous inspections and inventory information may suggest that on-site material properties and possibly collect samples for lab test shall be performed. Also axle load measurements may be beneficial.
2. Damage identification (location):
  - Previous damages in comparison to the previous inspection records (if any);
  - New damages in comparison to the previous inspection records (if any);
  - Evidence of previous repair (if any, either recorded or not).

# Illustrative example

3. Assessment/measurement of damage extend and intensity;
4. Identification of damage processes;
5. Qualitative assessment of resistance reduction based on observed damages. Preliminary (rough) assessment of resistance reduction on structural level (reliability). Is it necessary to perform in-depth investigations?
6. Assessment of safety (life and limb, e.g. skid resistance, falling concrete)

## **Step III Perform dynamic quality control (desk work, ref. next slides)**

1. Model the damage process
2. Estimate the remaining 'service life'
3. Define various maintenance scenarios
4. Compare the scenarios / determine the optimum scenario

# Illustrative example

- Vulnerable zones **not accessible** for visual inspection should be noted in the inspection report => can trigger further investigations.
- In the example those are high hogging moment regions (orange cycles at frame corners). Alternatively, engineering judgement (for example by observing deflection under current traffic load). Reasoning for either decision should be stated in the inspection report.
- In the vulnerable zones, **observations** are the following:
  - No **active** cracks or spalling at red zones; (uncertain cause and development of diagonal crack in HSS but it was repaired and not active);
  - Severe spalling with reinforcement section loss in orange zone (sagging moment region);
  - Hogging moment region inaccessible.

# Illustrative example

Protocol for other relevant data is also provided

Structure type	Date	Group	Observations							Qualitative assessment				
			Element	Type of element/material	Damage observation	Performance metric		Location/position	Damage Process	Primary KPI	Assessment level		Performance value (1-5)	
						Primary	Secondary				Component		Reliability	Safety
FA	present (month/year)	structural elements	Deck slab old	SA1/RC	Crack	Repaired	Diagonal	HSS	Not active	( R )	2	System	3	2
					Reinforcement corrosion	NA	NA	HMH	Corrosion	( R )	3			
					Reinforcement corrosion	10%	Longi-tudinal	HMS / bottom	Corrosion	( R )	4			
					Spalling	15m <sup>2</sup>	/	HMS / bottom	Corrosion	( S )	2			
					Efflorescence	5%	Bottom	HMH	Leaching	symptom	/			
			Deck slab new		Reinforcement corrosion	NA	NA	HMH	Corrosion	( R )	2			
					Reinforcement corrosion	5%	Longi-tudinal	HMS / bottom	Corrosion	( R )	3			
					Spalling	8 m <sup>2</sup>		HMS / bottom	Corrosion	( S )	2			
					Efflorescence	5%	Bottom	HMH	Leaching	symptom	/			
					Abutment 1	AB1/RC	Spalling	0.5m <sup>2</sup>	Outer surface	Abutment front	Corrosion		( R )	2
		Abutment 2	AB1/RC	Spalling	0.8m <sup>2</sup>	Outer surface	Abutment edge	Corrosion	( R )	2				
		Foundations	Shallow/RC	N/A (inaccessible)	/	/	/	/	( R )	1				
		Equipment	Curb	N/A				1%	Abrasion	( S )	Component	/	2	
			Railing	type	Deformation			5%	Impact	( S )	Component	/	2	
			Railing	type	Flaking			10%	Corrosion	( S )	Component	/	2	
Pavement /Overlay	Asphalt		No damage	/	/	/	/	( S )	Component	/	1			
Cornices	Monolithic		Spalling	4.5m <sup>2</sup>	/	80%	Corrosion	( S )	Component	/	2			

~ Classic BMS (computation of rough maintenance costs)

# Illustrative example

- Given that the system is statically indeterminate and bending failure is anticipated, it is possible that redistribution might occur. It should be noted that there is high uncertainty concerning hogging moment region. Since no issues concerning deflection under current traffic on the bridge is observed, it was concluded that those zones still have adequate resistance. Based on experience and elementary statics the **resistance reduction can be assessed as approximately 10%**. Qualitative performance scales are suggested.
- Performance value on structural level regarding reliability (R) shall **take virgin reliability, failure modes and vulnerable zones into account**.
- In the proposed protocol all findings, including present irrelevant damages and symptoms, should be recorded for the future reference.
- Other relevant data also reveal that the bridge is a part of an important highway (with big AADT) and that the required Availability (A) could affect previous (as well as present) decisions.

# Illustrative example

- In the next figure the “time” entity is added representing the **remaining service life**, i.e. the point in time at which reliability or safety will reach some threshold value (i.e. value 5 according to the proposed scale).
- **Qualitative performance scales are suggested.** The remaining service life, i.e. **when reaching an unacceptable failure return period**, is qualitative (semi-quantitative) estimated based on foreseen speed of deterioration (preferably backed up by inspection records or other verified models).

# Illustrative example

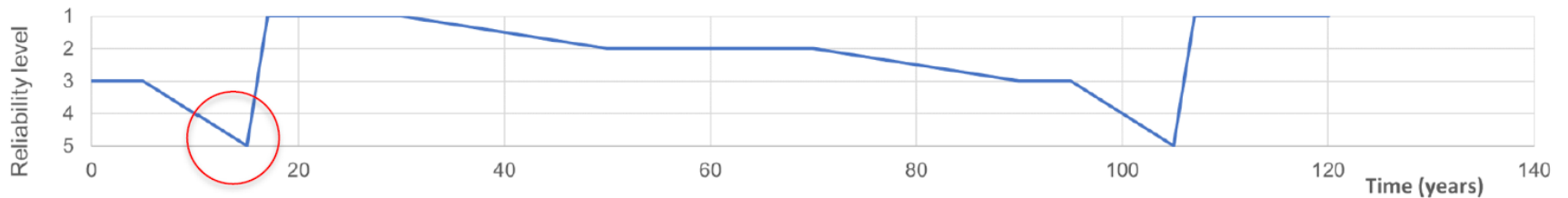
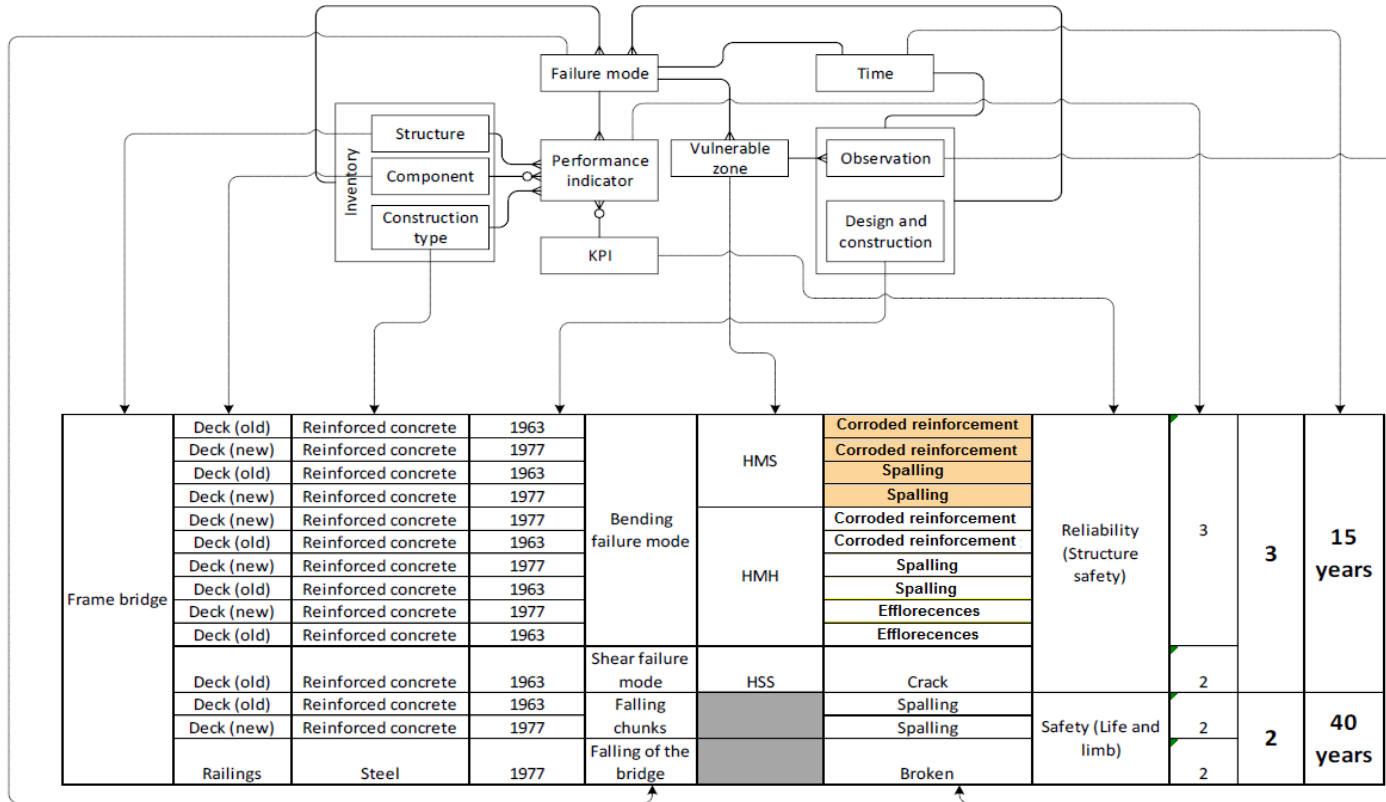

# Performance indicator scales (example)

- No alignment of scales (e.g. by translating all to a monetary unit)
- Reliability:**

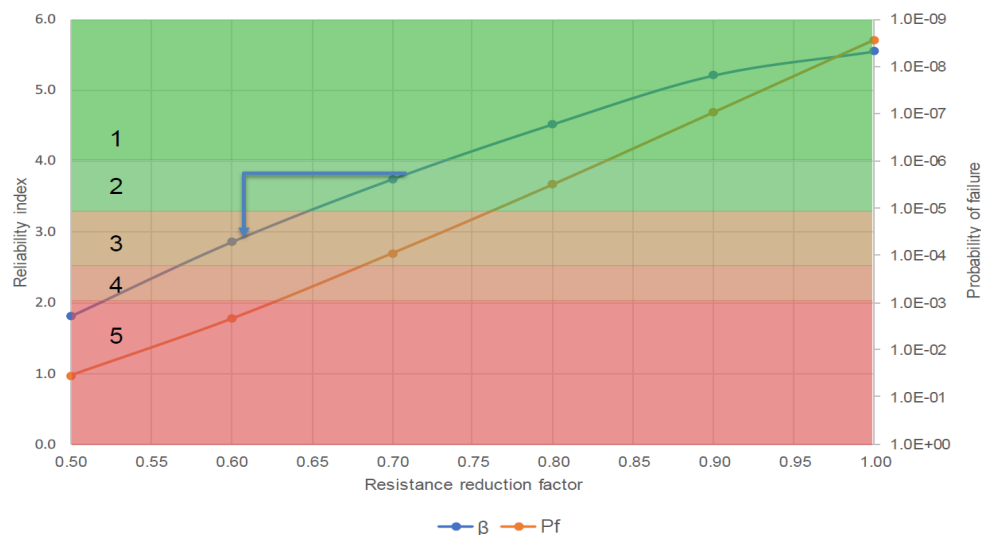

The below written scale is only valid when considering the **governing failure mode** in one of the vulnerable zones. Other failure modes and zones/areas are expected to have excessive capacity.

Scale related to reliability	Quantitative scale	Qualitative scale (structural safety, similar can be formulated for serviceability, e.g. $\beta > 1.5$ is a "1", EN1990)
1	> 4.00	New bridges and old bridges with no resistance reduction.
2	3.25-4.00	Old bridges with no or marginal resistance reduction compared to the virgin state (< 8%).
3	2.50-3.25	Old bridges with some resistance reduction compared to the virgin state (8 – 17%). Reassessment shall be performed before next inspection.
4	2.00-2.50	Old bridges with major resistance reduction compared to the virgin state (17 – 23%). Reassessment and possible intervention shall be performed shortly after inspection.
5	< 2.00	Severe resistance reduction. Immediate action is required.



# Performance indicator scales (example)

- Safety (life and limb):**

Scale related to safety	Quantitative scale	Qualitative scale
1	Injury return period > 100 yrs	No danger. It is very unlikely that a person could get injured because of current bridge performance.
2	Injury return period ~ 75 yrs	It is unlikely that a person could get injured because of current bridge performance.
3	Injury return period ~ 50 yrs	
4	Injury return period ~ 20 yrs	It is likely that a person could get injured because of current bridge performance. Intervention shall be performed shortly after inspection.
5	Injury return period < 10 yrs	Immediate danger. It is very likely that a person could get injured because of current bridge performance. Immediate action is required.

- Availability:**

Scale related to availability	Quantitative scale
1	No restrictions to traffic
2	Weight, speed and lane restrictions for heavy trucks
3	Closure except for cars and regular lorries. Possible lane restrictions for regular lorries.
4	Closure except for cars. Possible lane restrictions for cars.
5	Complete closure

**Duration of intervention** could be included in the above scale. However, no attempt in this respect has been made. If availability is monetised, as in many European countries, duration of intervention and its impact on user costs (discounted) is naturally considered.

# Illustrative example

- For each reliability level and with the respect of time preference, linked to the damage process, each country might establish maintenance scenarios.
- Example:

Reliability level	Scenario	Measures*
1	Reference	Do nothing (schedule for the next inspection in 5 years)
2	Reference	Do nothing (schedule for the next inspection in e.g. 5 years)
	Preventive basic	Strengthen to establish reliability level 1 ( $\beta > 4$ )
3	Reference	Do nothing (schedule for the next inspection in e.g. 5 years)
	Preventive 1	Do nothing (schedule for the next inspection in e.g. 3 years)
	Preventive 2	Repair to establish as design 'virgin' reliability ( $\beta = 3.8$ )
	Preventive basic	Strengthen to establish reliability level 1 ( $\beta > 4$ )
4	Reference	Do nothing (schedule for the next inspection in e.g. 3 years)
	Preventive 1	Do nothing (schedule for the next inspection in e.g. 1 years)
	Preventive 2	Repair to establish as design 'virgin' reliability ( $\beta = 3.8$ )
	Preventive basic	Strengthen to establish reliability level 1 ( $\beta > 4$ )
5	Reference	Strengthen to establish reliability level 1 ( $\beta > 4$ ) ( <b>mandatory!!!</b> )

# Illustrative example

- For each scenario, graphs for each KPI (in this case: R - reliability, C – costs, A – availability and S – safety) can be made. This has been performed for the illustrative example. "**Reference scenario**" is a "do-nothing" scenario. It should be noted that availability is established on the **network level**.
- Comparison of various scenarios might be performed in a number of ways, for example **monetization** is widely adopted method (for reliability and safety we need consequences of failure, i.e. Risk). However, that approach is not chosen in this COST action.
- When all **KPI are expressed on the scale of 1-5** (1-best, 5-worst) the spider diagram in the course of time can be generated (3D spider). **Scaling/ weighing factors is up to the owner.**
- It should be noted that in order to account for time preference, **discounting** is established for future expenditures. It is directly applicable to costs (C). If the same procedure is applied to other KPI's (R, S, A) then the 'average' or net present KPI for each scenario can be found and compared.
- For decision making the **net present KPI** in form of spider diagram is also presented.

# Illustrative example

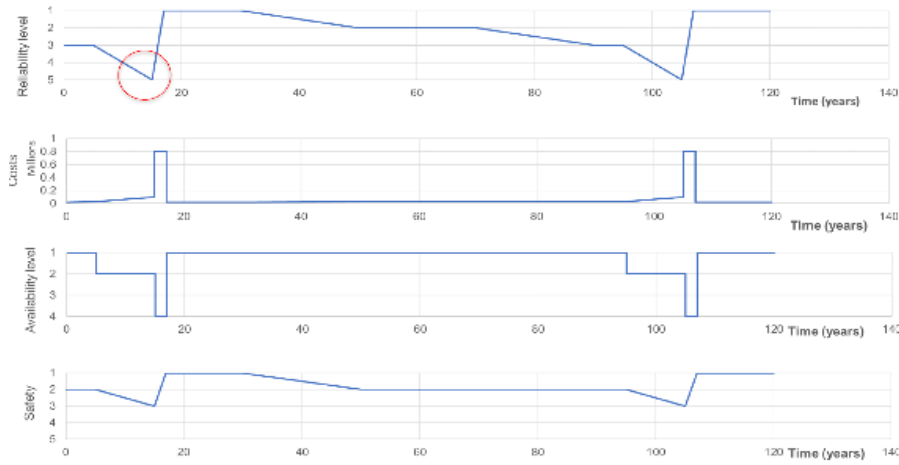

a - reference scenario

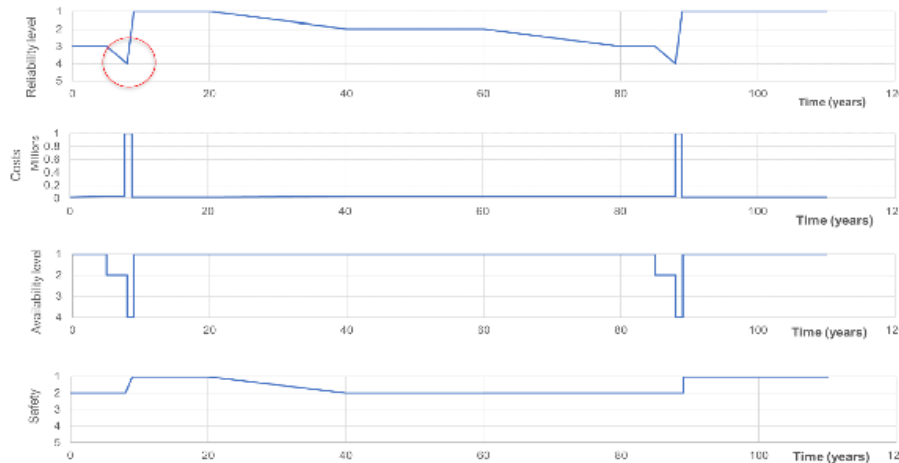

b - preventive scenario basic

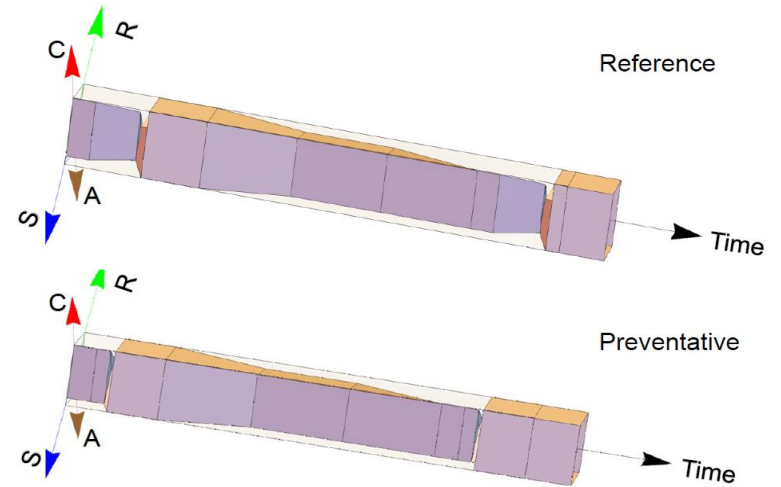

Preventative vs. Reference

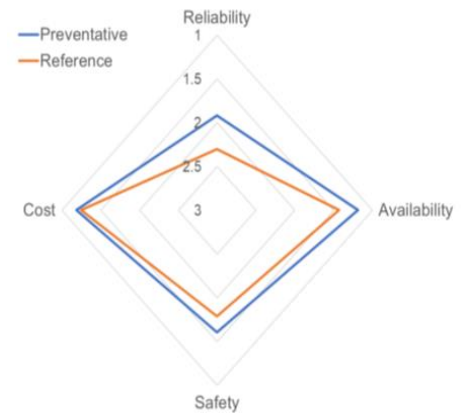

# Performance evaluation using Bayesian Nets

- Bayesian nets may be applied in order to evaluate the reliability rating.
- An example of the **simplified Bayesian network** for à priori reliability assessment is presented in Figure 16. As risk based assessments are considered as an advanced method, some of the input parameters may also be more advanced, e.g. load effects are based on actual traffic data. More complex Bayesian Nets may be found in e.g. [26].

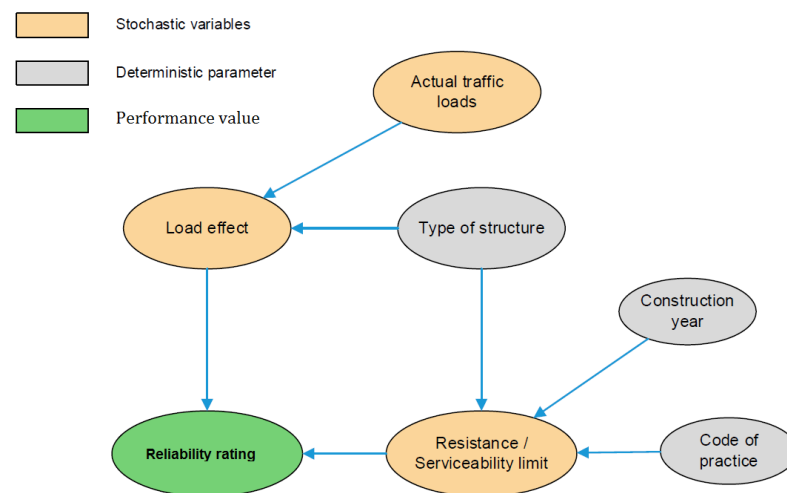

# Performance evaluation using Bayesian Nets

The à posteriori assessment of reliability is performed after an inspection or detailed investigations. The qualitative à priori values are updated based on the observations. Please note that the node, Actual traffic loads, has been excluded in the figures for simplicity.

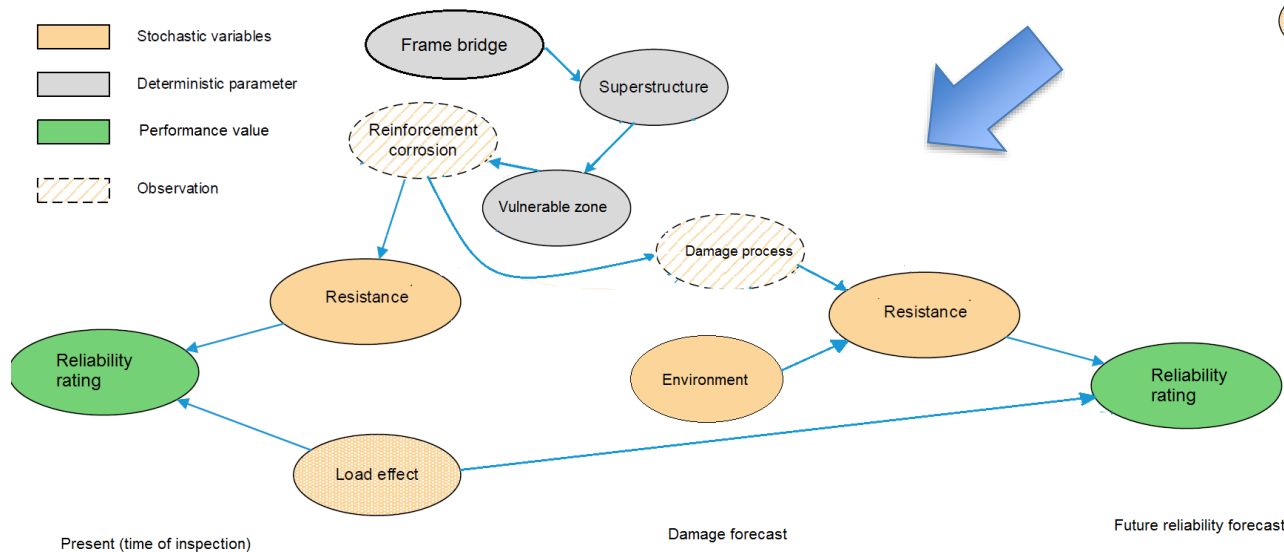
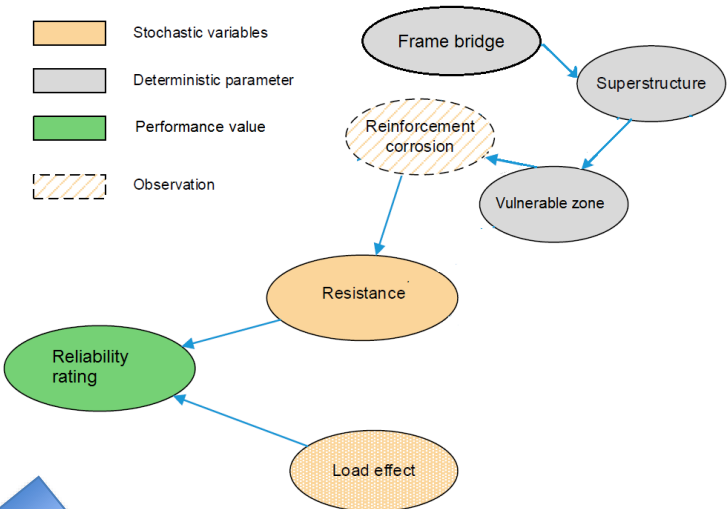

# Quantitative Inspection and Maintenance Planning

- Run inspection and maintenance scenarios with associated costs and availability based on performance prediction model

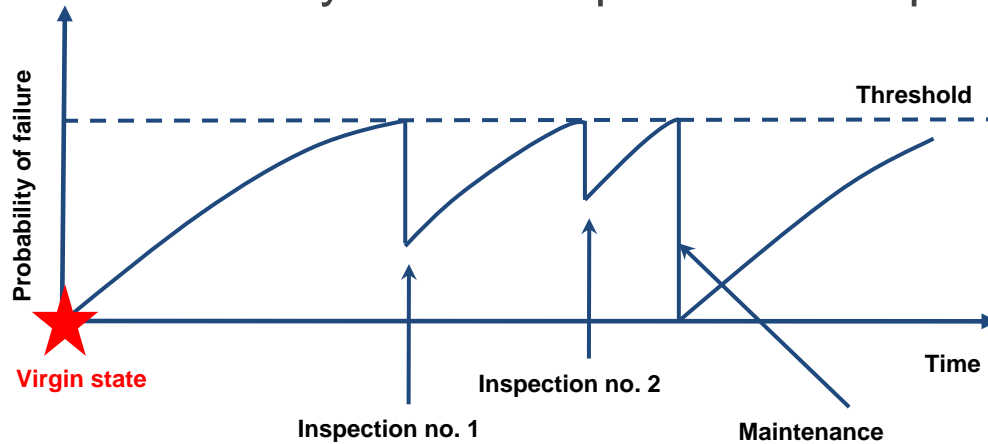

RBI

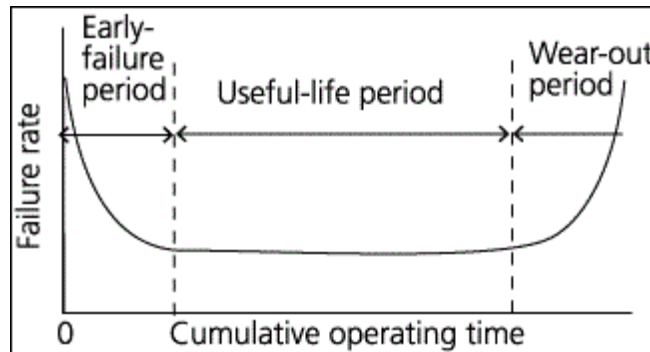

RCM

(E&M components on major bridge)



**TU1406**  
COST ACTION





# ARCH BRIDGES

## Case Studies

João Amado - Infraestruturas de Portugal, Lisbon

Cristina Costa - CONSTRUCT, Polytechnic Institute of Tomar, Tomar



# Introduction

- Example 1: Viaduct VT.5343
- Example 2: Durrães Bridge

# Example 1

## Viaduct VT.5343

# Viaduct VT.5343



- Located in Portugal, designed in 1937 and built in 1944;
- 3 open spandrel arches and two girder sections between arches;
- The main arch has a span of 98,4 meters with two reinforced concrete ribs;
- The two other arches have 43 meters span and three reinforced concrete ribs;
- Total width of the bridge deck is 24 meters with 5 lanes.

# Viaduct VT.5343

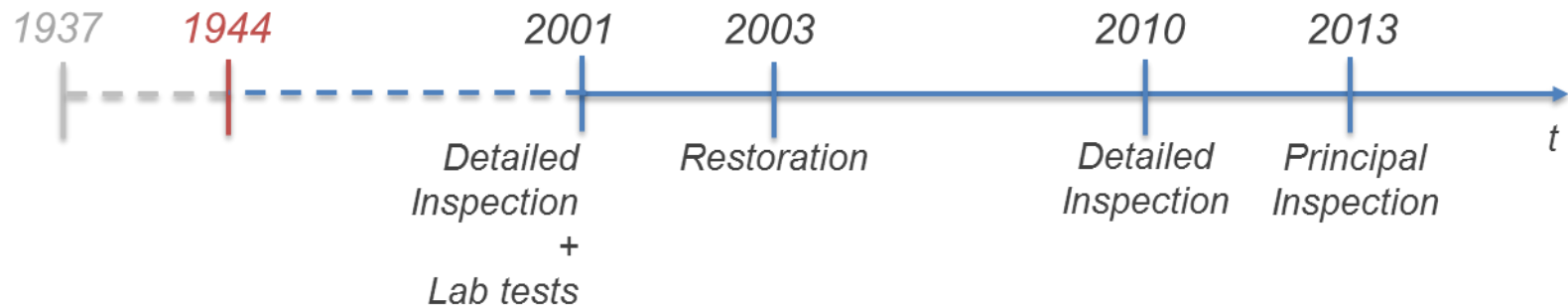

# Viaduct VT.5343

- 2001: Detailed Inspection and Laboratory tests



- Irregular cracks in arches' ribs and girders;
- Signs of reinforcement corrosion (red coloured areas);
- Girders presented signs of being crushed against the top of the piers (piers at arch springing – Arch 1);



- Bearings showed some signs movement capacity exhaustion and corrosion;
- Laboratory tests showed the existence of silica gel and ettringite;
- Potential for further alkali-silica reactions almost exhausted.

# Viaduct VT.5343

- 2001: Detailed Inspection and Laboratory tests

## Main observations:

- Cracks
- Movements' capacity exhaustion
- Crushed elements
- Silica gel and ettringite

## Damage Process:

- Expansive Reactions

*(size increase of the girders caused unexpected movements of bearings as well as crushing of the end of the girders against the supports)*



Structure type: Open Spandrel Concrete Arch Bridge									
Component	Construction type	Construction	Vulnerable Zone	Observation	Damage Process	Failure Mode	KPI	PI	
Deck girders	Reinforced Concrete	1944	High shear	Cracks (irregular)	Expansive Reactions	Shear failure mode	Reliability	3	4
Deck girders	Reinforced Concrete	1944		Crushing	Expansive Reactions	Shear failure mode		4	
Deck girders	Reinforced Concrete	1944		Silica gel	Alkali aggregate reaction (AAR)	-		-	
Deck girders	Reinforced Concrete	1944		Etringite	Sulphate action (SA)	-		-	
Bearings	Steel	1944	Bearings	Movements capacity exhaustion	Overloading	Bearing failure	Reliability	4	4
Bearings	Steel	1944		Corroded equipment	Corrosion	Bearing failure		2	
Arch ribs	Reinforced Concrete	1944	Compression Zone	Cracks (irregular)	Expansive Reactions (ASR+SA)	Compression failure mode	Reliability	2	2
Arch ribs	Reinforced Concrete	1944		Cracks (longitudinal)	Expansive Reactions (AAR+SA)	Compression failure mode	Reliability	2	
Arch ribs	Reinforced Concrete	1944		Red color areas near major cracks	Corrosion of Reinforcement	-	-	-	
Arch ribs	Reinforced Concrete	1944		Silica gel	Alkali aggregate reaction (AAR)	-	-	-	
Arch ribs	Reinforced Concrete	1944		Etringite	Sulphate action (SA)	-	-	-	



# Viaduct VT.5343

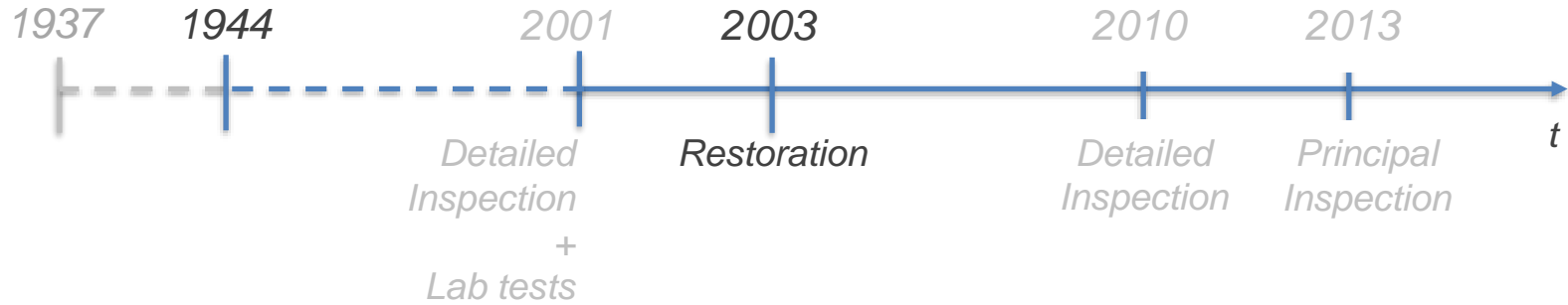

# Viaduct VT.5343

- 2010: Detailed Inspection



- Overall good condition, no important signs of expansive reactions;
- New signs of crushing/ detachment of the deck girders over the pier at arch springing (1<sup>st</sup> Arch);
- With the potential for further alkali-silica reactions almost exhausted it is likely that another damage process is occurring;
- High compression forces should be present at deck level;
- Possible movement of the abutment due to previous earthworks near foundation.

# Viaduct VT.5343

- 2013: Principal Inspection

## Main observations:

- Crushed girders over the pier at arch springing;
- Concrete detachment on top of the pier at arch springing, below the girders;
- Cracks on the abutment side walls



## Damage Process:

*(Abutment Displacement/ Rotation)*

- Soil Failure
- Overloading

# Viaduct VT.5343

- 2013: Principal Inspection

Structure type: Open Spandrel Concrete Arch Bridge									
Component	Construction type	Construction	Vulnerable Zone	Observation	Damage Process	Failure Mode	KPI	PI	
Deck girders	Reinforced Concrete	1944	High shear	Crushing	Soil Failure/Overloading	Shear failure mode	Reliability		2
Pier at arch springing	Reinforced Concrete	1944	Girder support	Detachment	Soil Failure/Overloading	Loss of support	Reliability		2
Abutment	Concrete	1944	Foundation	Cracks	Soil Failure	Tilting	Reliability		3

Scale related to reliability	Quantitative scale	Qualitative (written) scale
1	> 4.00	New bridges and old bridges with no resistance reduction.
2	3.25-4.00	Old bridges with no or marginal resistance reduction compared to the virgin state (< 8%).
3	2.50-3.25	Old bridges with some resistance reduction compared to the virgin state (8 – 17%). <u>Reassessment shall be performed before next inspection.</u>
4	2.00-2.50	Old bridges with major resistance reduction compared to the virgin state (17 – 23%). Reassessment and possible intervention shall be performed shortly after inspection.
5	< 2.00	Severe resistance reduction. Immediate action is required.

# Example 2

## Durrães Bridge

# Durrães Bridge

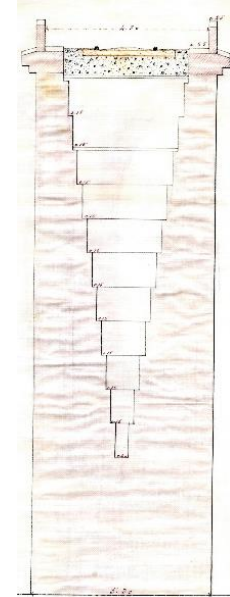

- Located in Portugal, near Porto, dates back to late 19<sup>th</sup> century (1878)
- Masonry arch bridge made of granite stone regular blocks in the principal elements and irregular blocks, mortar mixed with cement in the infill (infill masonry)
- 16 arches, ~9 m span and 0.7 m thickness
- 15 piers and 2 abutments
- Rectilinear longitudinal profile, total length of ~178 m and 5.3 m width
- Maximum gap between the ground level and the top face of the deck is ~22 m

# Durrães Bridge

- 2015: Visual Inspection

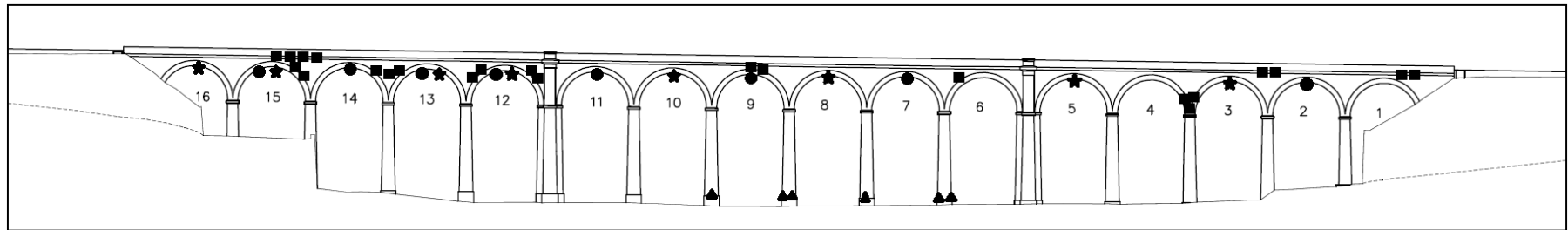
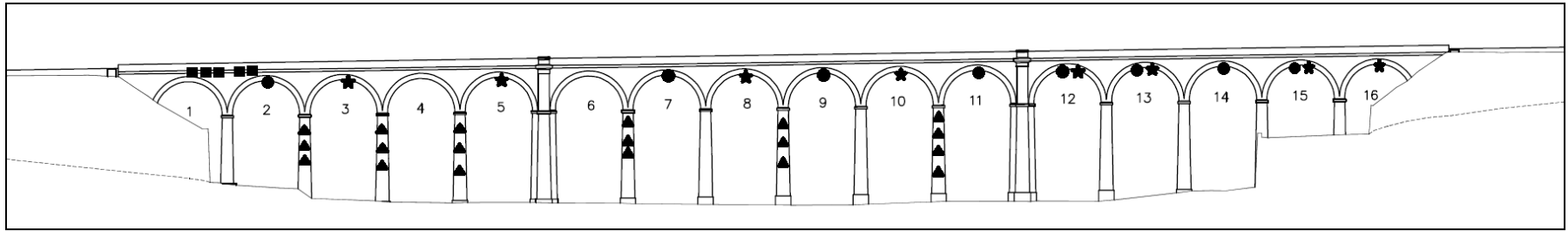

**Legend:** ■ Vegetation ▲ Lack of mortar ★ Cracking in the central zone of the arch ● Cracking in the interface arch-spandrel wall

Defects associated to environmental, physical and chemical actions

Defects associated to mechanical actions

# Durrães Bridge

- 2015: Visual Inspection



- Humidity and water flowing
- Vegetation, moss, lichens and dirt deposits
- Black films
- Efflorescence
- Lack of mortar
- Stone degradation (erosion and meteorization)

Defects associated to environmental, physical and chemical actions



# Durrães Bridge

- 2015: Visual Inspection

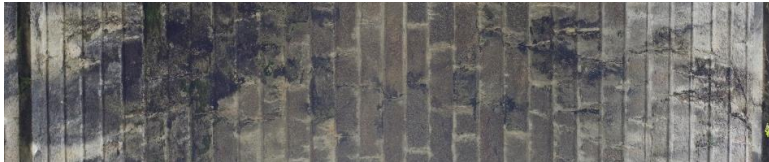

- Longitudinal cracking in the intrados of the arches (near the face and in the central axis)
- Block fracture
- Cracking at the mortared joints
- Joint opening

Defects associated to mechanical actions

# Durrães Bridge

- 2015: Experimental and numerical characterization

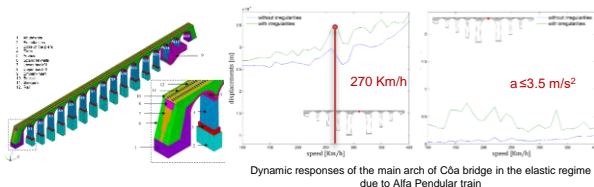
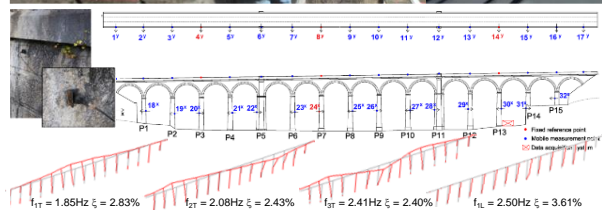

- Detailed survey on geometry and material constitution of elements
- Mechanical characteristics of **stone blocks** and **masonry joints** evaluated from **lab tests** on material samples
- *In situ* mechanical characteristics of **masonry** from **flat-jack testing**; **infill material** from **pressuremeter testing**
- **Dynamic identification** based on *in situ* vibration tests
- **Numerical assessment** of the bridge response under traffic loading using calibrated models

# Durrães Bridge

- 2015: Visual Inspection

## Main observations:

- Cracks  
(longitudinal cracks along the central axis of the arch intrados)
- Rupture  
(Block fracture - local)
- Deteriorated mortar joints  
(Lack of mortar)
- Vegetation
- Wet spots
- Efflorescence

## Damage Process:

- Overloading / Atypical vibrations (vibration)
- Multiple DP (overloading, soil failure, etc.)
- Abrasion/Erosion
- Biological growth
- Hydraulic inadequacy
- Sulphate action

# Durrães Bridge

Component	Construction type	Construction	Vulnerable Zone	Observation	Damage Process	Failure Mode	KPI	PI
Arch	Stone masonry	1878	Spandrel-arch connection	Cracks (longitudinal cracks along the spandrel-arch connection)	Overloading / Atypical vibrations (vibration)	Interaction in transverse direction	Reliability	3
Arch	Stone masonry	1878	Arch intrados	Cracks (longitudinal cracks along the central axis of the -arch intrados)	Overloading / Atypical vibrations (vibration)	Interaction in transverse direction	Reliability	3
Arch	Stone masonry	1878		Rupture (Block fracture - local)	Multiple DP	-	-	-
Arch	Stone masonry	1878		Deteriorated mortar joints (Lack of mortar)	Abrasion/Erosion	-	-	-
Arch							-	-
Arch							-	-
Arch							-	-
Spandrel wall – w							-	-
Spandrel wall – w							-	-
Spandrel wall – w							-	-
Spandrel wall – e							-	-
Spandrel wall – e							-	-
Spandrel wall – e							-	-
Pier - north							-	-
Pier - north							-	-
Pier - north							-	-
Pier - south							-	-
Pier - south	Stone masonry	1878		Vegetation	Biological growth	-	-	-
Pier - south	Stone masonry	1878		Wet spots	Hydraulic inadequacy	-	-	-

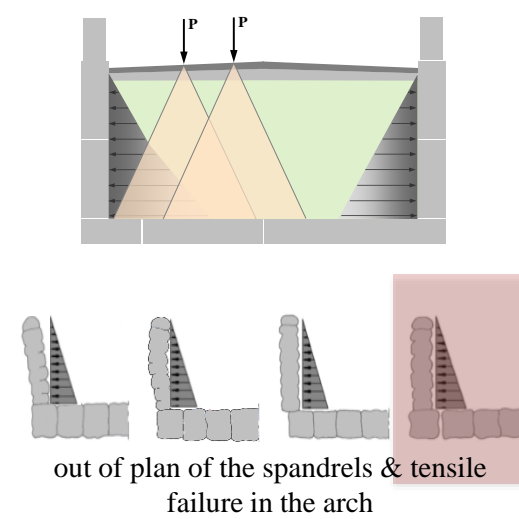
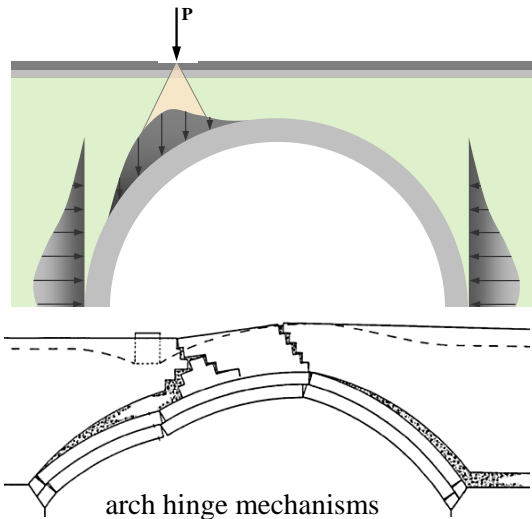

# Durrães Bridge

Component	Construction type	Construction	Vulnerable Zone	Observation	Damage Process	Failure Mode	KPI	PI
Arch	Stone masonry	1878	Spandrel-arch connection	Cracks (longitudinal cracks along the spandrel-arch connection)	Overloading / Atypical vibrations (vibration)	Interaction in transverse direction	Reliability	3
Arch	Stone masonry	1878	Arch intrados	Cracks (longitudinal cracks along the central axis of the -arch intrados)	Overloading / Atypical vibrations (vibration)	Interaction in transverse direction	Reliability	3

Scale related to reliability	Quantitative scale	Qualitative (written) scale
1	> 4.00	New bridges and old bridges with no resistance reduction.
2	3.25-4.00	Old bridges with no or marginal resistance reduction compared to the virgin state (< 8%).
3	2.50-3.25	Old bridges with some resistance reduction compared to the virgin state (8 – 17%). <b>Reassessment shall be performed before next inspection.</b>
4	2.00-2.50	Old bridges with major resistance reduction compared to the virgin state (17 – 23%). Reassessment and possible intervention shall be performed shortly after inspection.
5	< 2.00	Severe resistance reduction. Immediate action is required.



**TU1406**  
COST ACTION



# Case study – road concrete arch bridge Nerestce

**Pavel Ryjáček** – Faculty of civil engineering CTU in Prague, Czech Republic

**Milan Petřík** – Mott MacDonald CZ, Czech Republic



# Bridge introduction

- The concrete arch bridge is located on the main road between Prague and České Budějovice, close to a small village Nerestce.
- The location shown on the map of traffic intensity
- 9679 cars/24h, from that 953 heavy cars/24h.

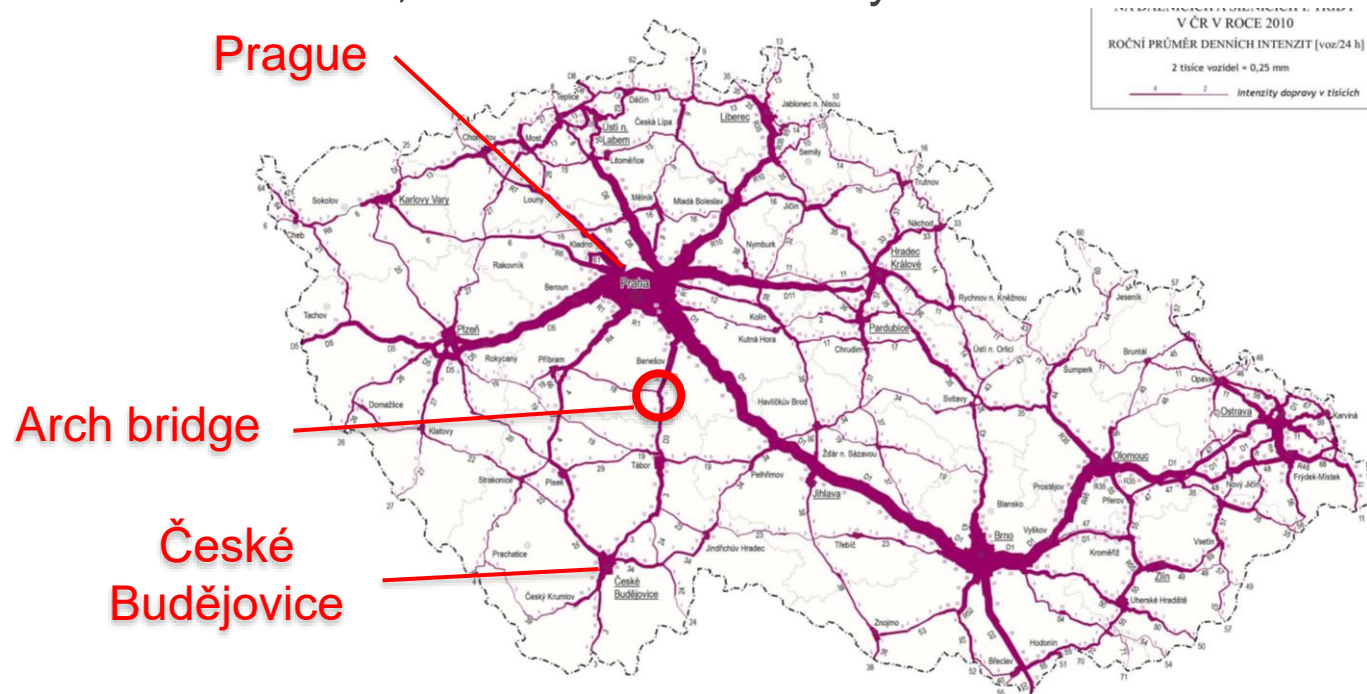



# Bridge introduction

- Main span - 50m, bridge length - 80m.
- Three dilatation parts - side parts are concrete frames, central part supported by the concrete arch.
- Concrete abutments and arch pad foundation on the rock, probably connected in the ground.

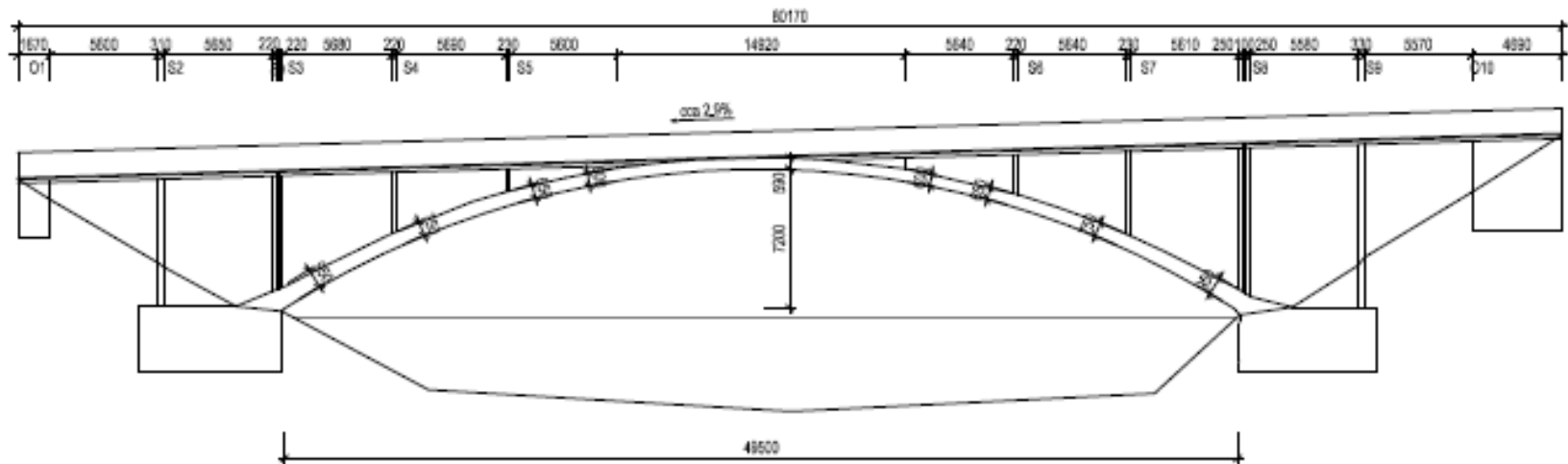

# Bridge introduction

- The bridge serves to 2 lanes, total width is 112,6m.
- There is asphalt pavement on the bridge of thickness up to 200 mm!!
- The concrete railing used
- Water is drained by vertical tubes.

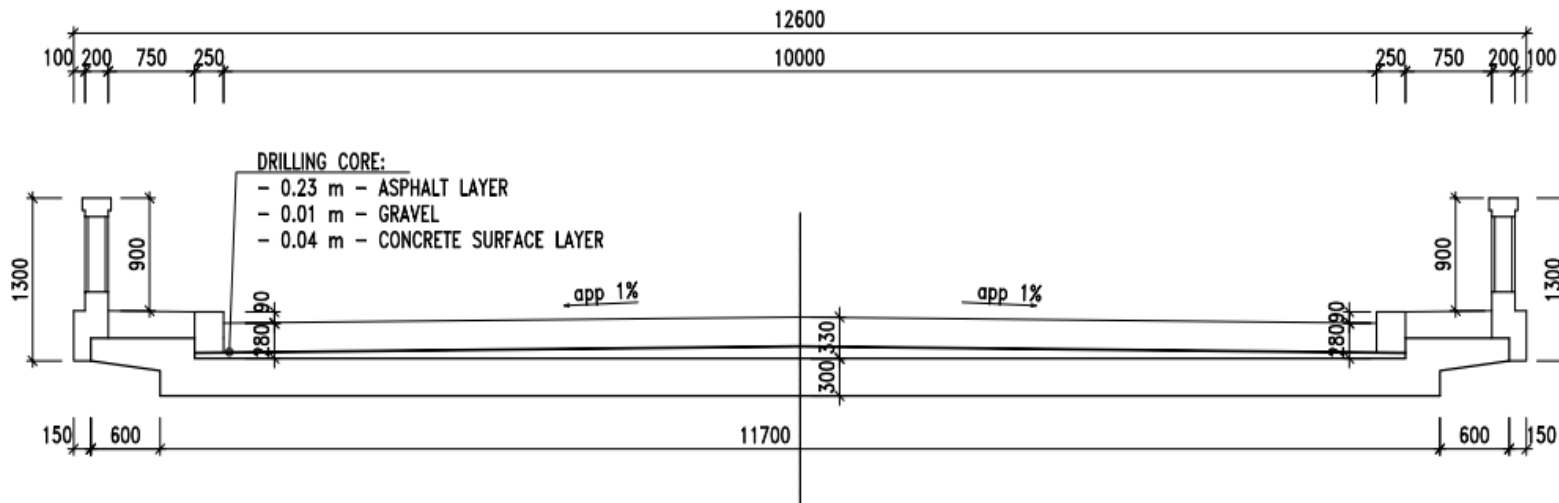

# Bridge load capacity

- Normal capacity of the unlimited number of vehicles:  $V_n = 26.7 \text{ t}$
- The capacity of the one single vehicle on the bridge:  $V_r = 66 \text{ t}$
- Exceptional capacity for the heavy special transport:  $V_e = 175 \text{ t}$
- Critical members: vertical walls for  $V_n$ , bridge deck for  $V_r$

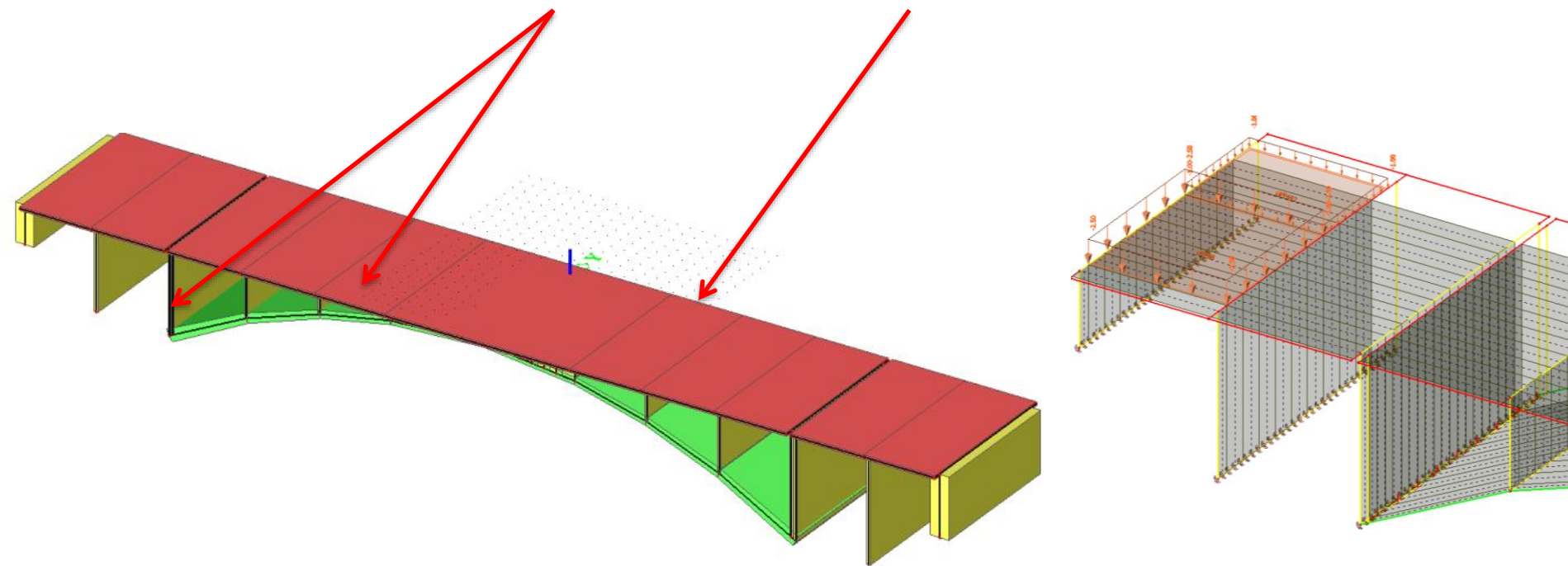

# Formal bridge status - rating

- Rating:
  - Superstructure – V
  - Substructure – V

I	Excellent	1
II	Very good	1
III	Good	1
IV	Satisfactory	0,8
V	Bad	0,6
VI	Very bad	0,4
VII	Emergency	0,2

- Rating:
  - Availability – 3

1	Available
2	Available with conditions
3	Available with limitations
4	Limited availability
5	Unavailable

# Bridge defects

- Concrete deterioration, the reinforcement corrosion. Mainly below the expansion joints on the piers and arch.

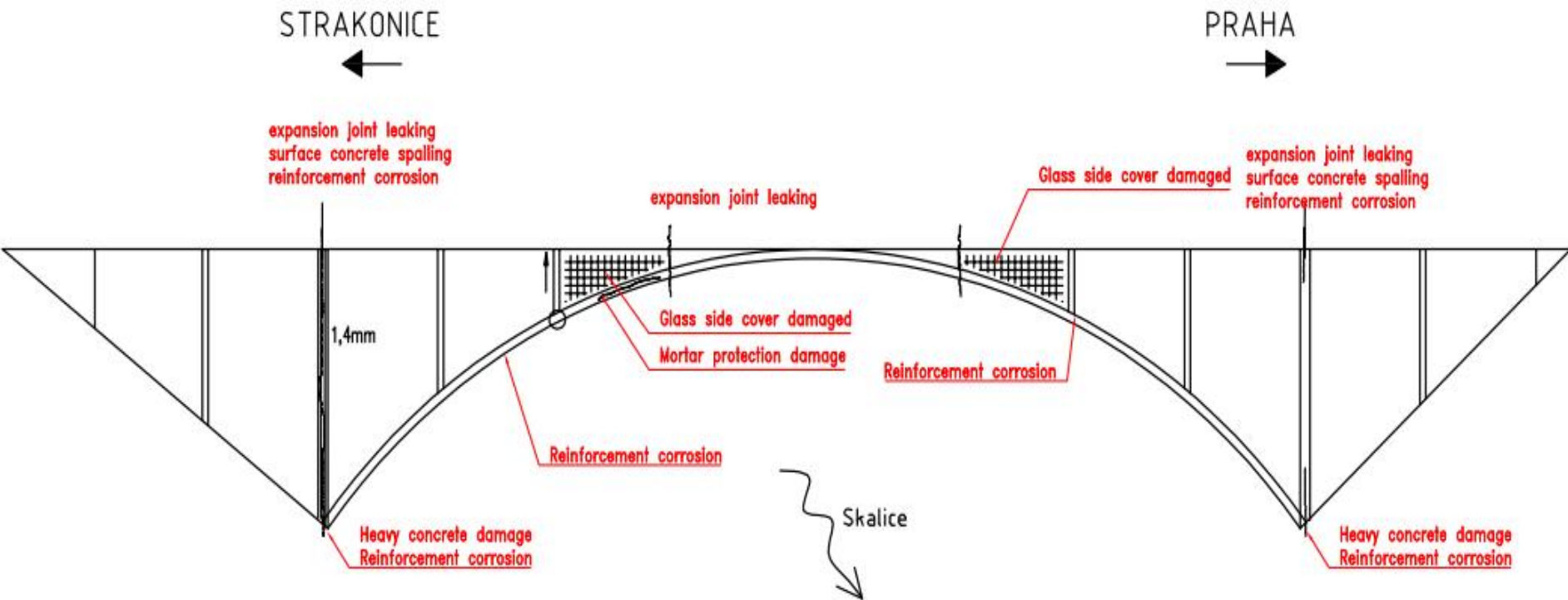

# Bridge defects

- Concrete deterioration, the reinforcement corrosion. Mainly below the expansion joints on the piers and arch.
- The arch plan is shown bellow:

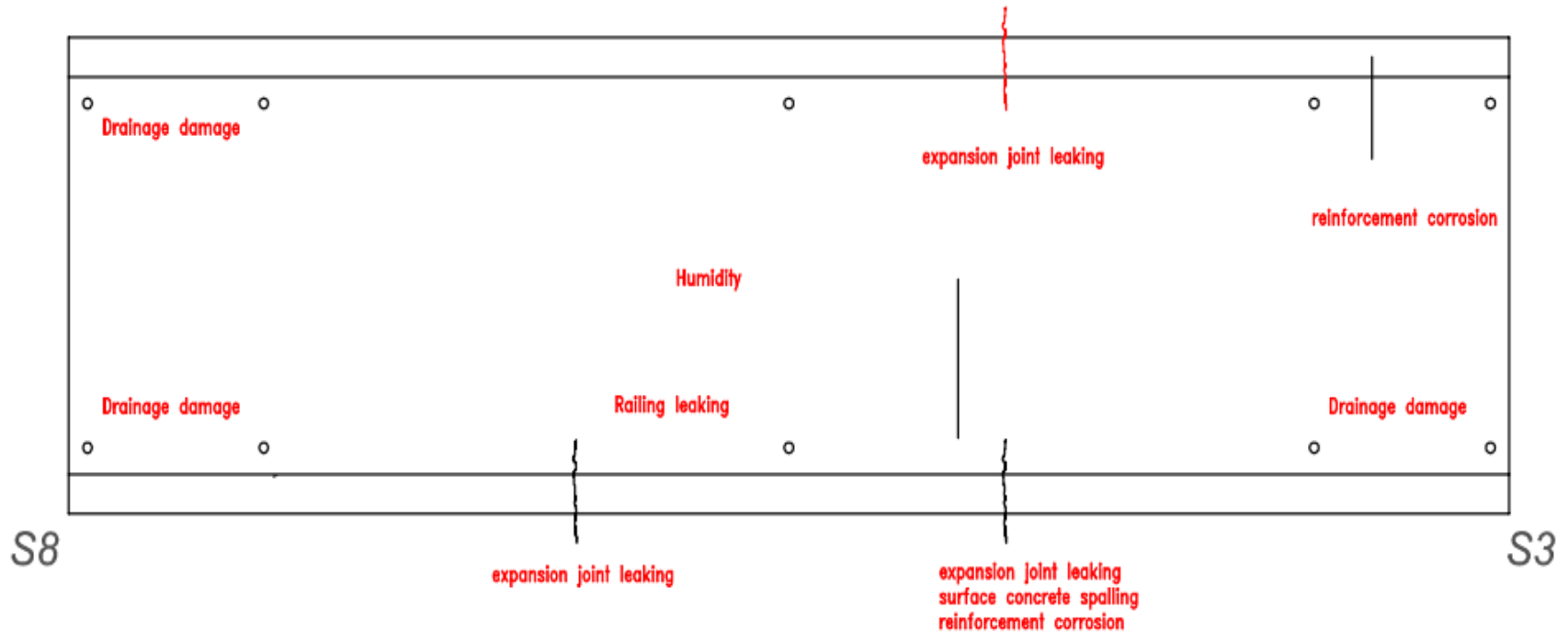

# Bridge defects

- Defects of pavement, enormous thickness of pavement
- Inefficiency of drainage



# Bridge defects

- Damage waterproofing of the arch and spandrel walls
- Waterproofing defects,





# Bridge defects

- Concrete deterioration, the reinforcement corrosion. Mainly below the expansion joints on the piers and arch.



# Bridge defects

- Deterioration of the foundation at the abutment – the status 6 years old, repaired



# Bridge defects

- Concrete deterioration, the reinforcement corrosion. Mainly below the expansion joints on the piers and arch.
- Deterioration of the concrete railing



# Potential failure modes of the bridge

- Vertical walls under the expansion joint failure – global bridge failure due to loss of stability under live load due to concrete degradation and reinforcement corrosion under leaking expansion joint.
- Main arch failure – global bridge failure due to concrete degradation and reinforcement corrosion under expansion joint location due to expansion joint leakage.

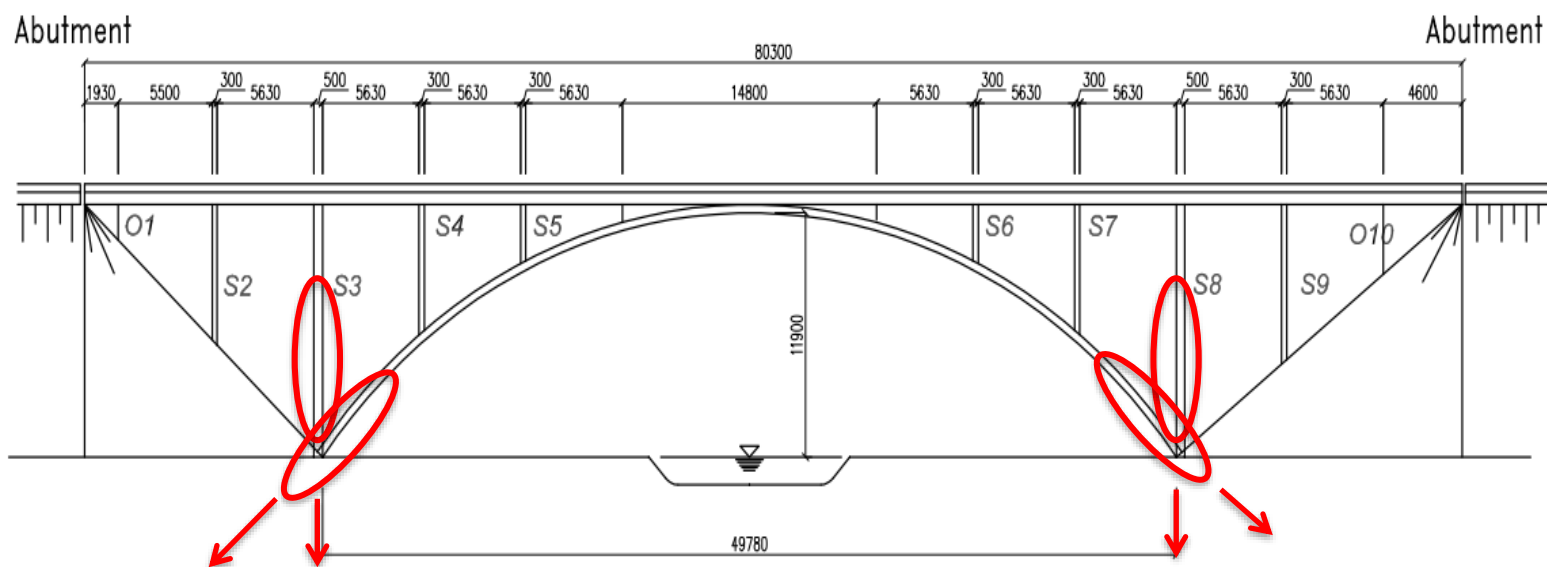



# Material testing and diagnostics

- Compression tests – good results – considered as **C30/37**
- Alkali – silica reaction – satisfies
- Carbonation – max. 8mm, usually 0mm



Specimen	Compressive strength [MPa]
NK1	33.8
01_1	31.7
01_2	36.9
02_1	29.8
S1	32.1
S2	31.8



# Material testing and diagnostics

- Chlorides amount – max. 0,059%
- All samples were exposed to the 75 freezing cycles – only one sample failed



# Key performance indicators

- KPI are provided in with best practice knowledge of the team and experiences with bridge inspection in CZ, The indicators are evaluated and also based on the model experiences.

Component	Material	Failure mode	Vulnerable zone	Symptoms	KPI	Performance indicator		Estimated failure time
Wall under E.J.	Reinforced concrete	Global failure	E.J. connection	E.J. leakage, reinforcement	Reliability (Structure safety)	2	2	<b>20 years</b>
Arch	Reinforced concrete	Global failure	Arch under E.J.	E.J. leakage, reinforcement		2		<b>35 years</b>
Top slab	Reinforced concrete	Local slab failure	Slab in hinge position	Hinge leakage and reinforcement		2		<b>35 years</b>
Abutment 01	Subsoil	Loss of stability	Abutment foundation	Undermined abutment		2		<b>40 years</b>
Parapets	Reinforced concrete	Parapet collapse	Bottom section of parapet	Reinforcement corrosion	Safety	2	2	<b>10 years</b>
Pavement	Asphalt concrete	Skid resistance	Top surface	Crack & sweating & deformation		2		<b>5 years</b>



# Bridge evaluation

- First **Referenced** approach consider a lack of any repairs of bridge except of very basic ones on the pavement. The bridge defects are developed till bridge failure and whole bridge is replaced with new structure.
- Second **Preventative** approach consider set of repairs during life time cycle to prevent further defect development and overall damage to the structure.

# Referenced approach

- A lack of any repairs of bridge except of very basic ones:
- **Pavement** failure in 5 years due to crack development, sweating and deformation in five years, then pavement repair.
- Concrete **parapets** collapse in 10 years (decrease of availability & safety) – placing of temporary crash barriers
- **Doubled wall** under expansion joint failure in 20 years
- Bridge **failure and replacement** with new structure in **20** years
- Preventative approach on the new bridge (pavement replacement every 20 years and bridge repair every 40 years).

# Referenced approach

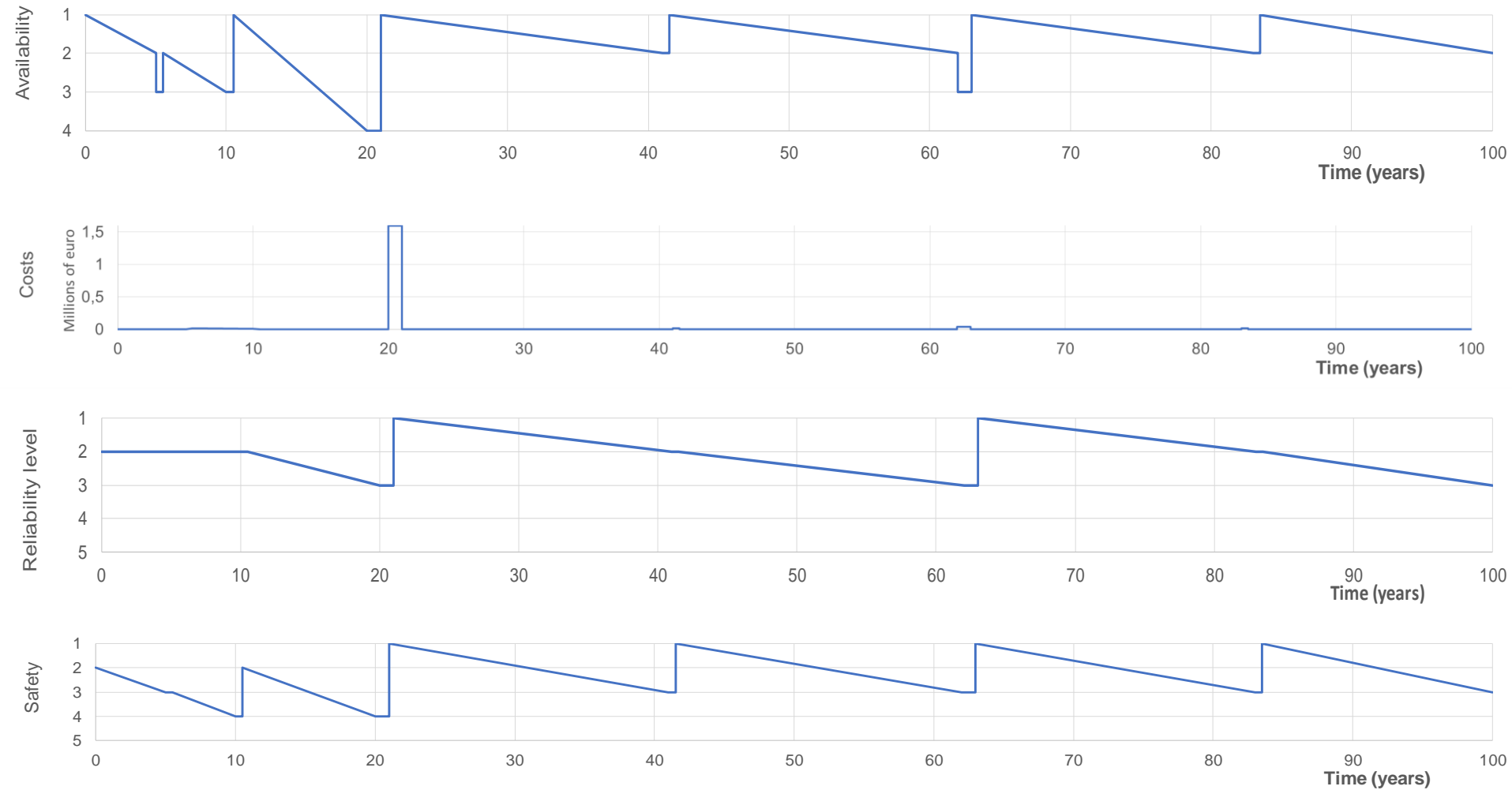

# Preventative approach

- Preventative repair after 10 years:
- **Pavement** failure in five years due to crack development, sweating and deformation in five years (shall be repaired).
- **Concrete parapets** collapse in 10 years
- The whole bridge and accessories **repair** is considered in the same time **10 years**.
- In following years the preventative approach on the repaired bridge is assumed (pavement replacement every 20 years and bridge repair every 40 years).

# Preventative approach

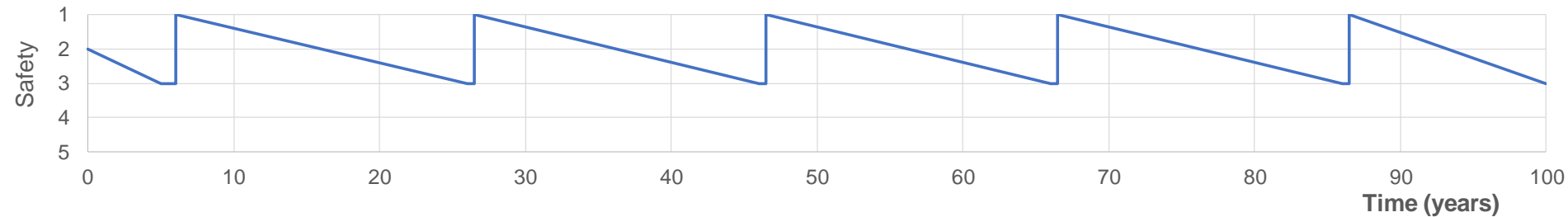
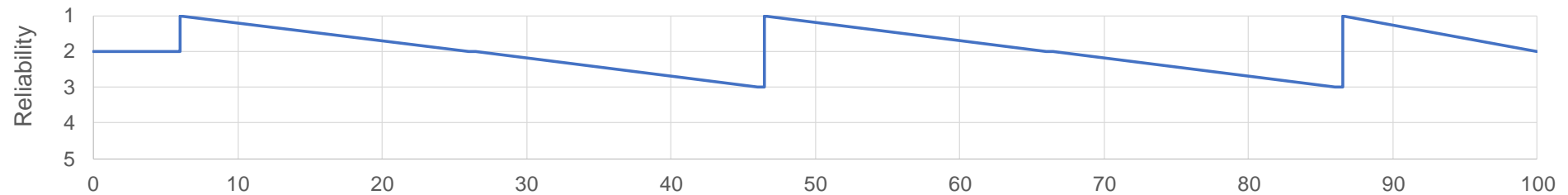
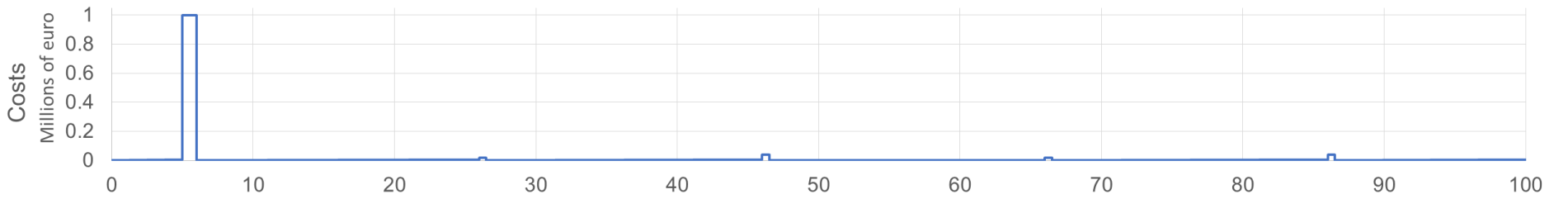
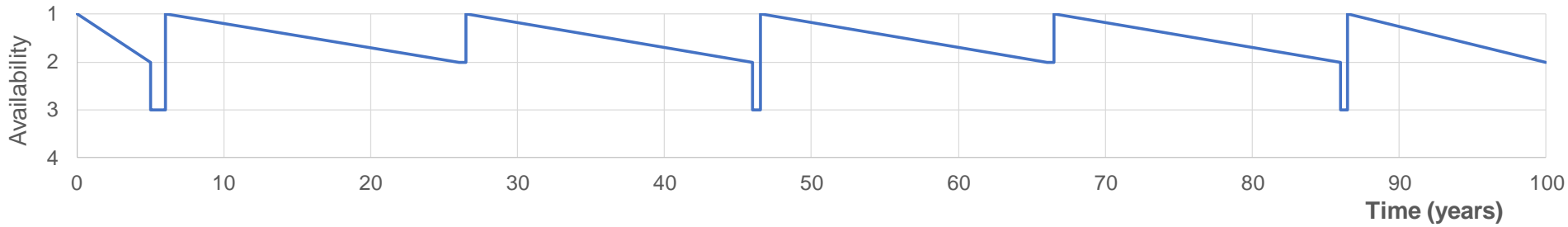

# Comparison of the approaches

- The preventative approach is more appropriate for the arch bridge - the indicators shows more favorable results for all aspects.

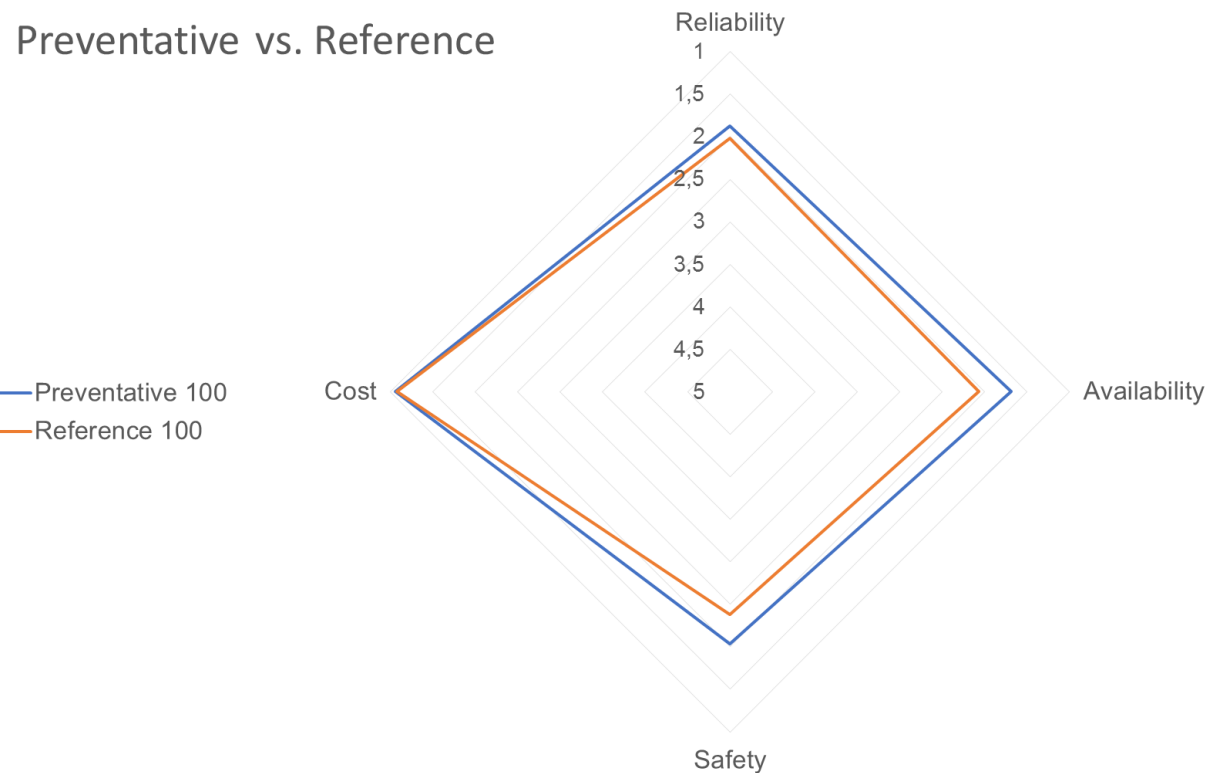



**TU1406**  
COST ACTION